

User Manual

Homira KNX 3-fold 0-10V Mini Dimmer

HM-FM-03.LED

KNX/EIB Home and Building Control System

Attentions

1. Please keep devices away from strong magnetic field, high temperature, wet environment;



2. Do not fall the device to the ground or make them get hard impact;



3. Do not use wet cloth or volatile reagent to wipe the device;



4. Do not disassemble the devices.

Contents

Chapter 1 Summary	1
Chapter 2 Technical Data.....	1
Chapter 3 Dimension and Structural Diagram.....	4
3.1 Dimension Diagram	4
3.2 Structural Diagram	4
Chapter 4 Parameter setting description in the ETS.....	5
4.1. KNX Secure	5
4.2 Parameter window "General"	9
4.3 Parameter window"Output setting"	11
4.3.1 Parameter window"Dimming X (X=A,B,C)"	14
4.3.1.1 Parameter window"User defined dimming curve"	19
4.3.1.2 Parameter window"Scene function"	21
4.3.1.3 Parameter window"Time function"	23
4.3.1.4 Parameter window"Threshold function"	27
4.3.1.5 Parameter window"Forced function"	29
4.3.1.6 Parameter window"Safety function"	31
4.3.1.7 Parameter window"Sequence X (X=1~4)"	32
4.3.2 Parameter window"Switch X (X=A,B)"	35
4.3.2.1 Parameter window"Time"	38
4.3.2.1.1 "Delay"	39
4.3.2.1.2 "Flashing "	40
4.3.2.1.3 "Staircase"	42
4.3.2.2 Parameter window"Output X: Logic"	44
4.3.2.3 Parameter window"Output X: Scene"	47
4.3.2.4 Parameter window"Output X:Forced"	48
4.3.2.5 Parameter window"Output X: Operation hours counter"	49
4.3.3 Parameter window"Dimming CCT"	51
4.3.3.1 Parameter window"Scene function"	58
4.3.3.2 Parameter window"Forced function"	60
4.3.3.3 Parameter window"Sequence X (X=1~4)"	63

4.3.4	Parameter window“Dimming RGB”	67
4.3.4.1	Parameter window“Scene”	72
4.3.4.2	Parameter window“Forced function”	74
4.3.4.3	Parameter window“Sequence X (X=1~4)”	76
4.4	Parameter window“UI setting”	79
4.4.1	Parameter window“Input X(X=1~8)”	81
4.4.1.1	Parameter window“Switch”	82
4.4.1.2	Parameter window“Dimming”	85
4.4.1.3	Parameter window“Value output”	88
4.4.1.4	Parameter window“Scene control”	89
4.4.1.5	Parameter window“Blind”	91
4.4.1.6	Parameter window“Shift register”	93
4.4.1.7	Parameter window“Multiple operation”	96
4.4.1.8	Parameter window“Delay mode”	98
4.4.2	Parameter window“LED x”	99
Chapter 5	Description of Communication Object.....	101
5.1	Communication object of “General”	102
5.2	Communication object of“Output setting”	103
5.2.1	Communication object of “Dimming X(X=A,B,C)”	103
5.2.2	Communication object of “Switch X(X=A,B)”	107
5.2.3	Communication object of “Dimming CCT”	112
5.2.4	Communication object of “Dimming RGB”	115
5.3	Communication object of“UI setting”	120
5.3.1	Communication object of “Input X(X=1~8)”	120
5.3.2	Communication object of “LED X(X=5~8)”	125

Chapter 1 Summary

The 1-10V Dimming Actuator, 3-Fold, Flush Mounted is a module that integrates multiple dimming output functions, including normal dimming, CCT and RGB output in addition to switch output, dry contact input and LED output indication functions. The corresponding output function can be configured according to actual application requirements.

This module is compact and small in design, Flush mounted, and can be installed in a 86 type wall-mounted box. The output adopts screw terminal to realize electrical connection, and the bus connection is directly connected via KNX terminal. The additional power supply is not required except KNX bus.

This manual provides detailed technical information about the 1-10V Dimming Actuator, 3-Fold, Flush Mounted for users as well as assembly and programming details, and explains how to use the device by the application examples.

The function of the 1-10V Dimming Actuator, 3-Fold, Flush Mounted is summarized as follows:

- Switch, Relative dimming/Absolute dimming, support normal dimming output, RGB output, CCT output

- Switch output: connect some electrical loads. With general switch, staircase lighting, light flashing and switch delay, scene, logic and force operation etc.

- Normal dimming output: support staircase lighting, flashing switch and delay

switch, scene, threshold forced operation, safety operation, sequence function and 3 dimming curves (including logarithmic, root, linear), as well as user defined curves

- RGB/CCT output: support scene, forced operation and sequence function

- Status feedback of switch, brightness

- Reset behaviour after download/bus recovery

- Dry contact input detection: support the functions of switch, dimming, value output, scene control, blind, shift register, multiple operation and delay mode

- Drive LED indicator: Connect type supports common-anode, can be 12V

- Support the KNX Data Secure

Chapter 2 Technical Data

Power supply	Bus voltage	21-30V DC, via the KNX bus
	Bus current	<22mA/24V,<18mA/30V (work) <10mA/24V,<9mA/30V (standby)
	Bus consumption	<540mW (work) <270mW (standby)
	Capacitor charge current	<29mA
Output	Un rated voltage	230V AC (50/60Hz)
	In rated current	single channel max.16A (Resistive load)
	Inrush current	370A/1.25ms
	Electrical endurance	>5x10 ⁴
Output LED	12V,current limiting with 4 mA	
Connection	KNX	Bus connection terminals
	Outputs	Screw terminals, Wire Range 2.5 mm ² Torque 0.4N-m
	Input/Output LED	≤10M
Operation and display	Programming button and Red LED	For assigning the physical address
	Green LED flashing	For displaying application layer running normally
Temperature	Operation	-5 °C ... + 45 °C
	Storage	-25 °C ... + 55 °C
	Transport	- 25 °C ... + 70 °C
Environment	Humidity	<93%, except dewing
Mounting	86 type wall-mounted box (recommend to use the depth with 70mm)	

Note: For the relay parameters, the above load is only for a single lamp. When multiple lamps are connected in parallel, the load can be reduced. Although the power is constant, the instantaneous

inrush current will increase, which will easily melt the relay contacts. Therefore, in normal use, based on the measured current, the measured maximum inrush current must be within the allowable range.

Application program:

Application program	Max. number of communication objects	Max. number of group addresses	Max. number of associations	Secure group addresses
1-10V Dimming Output/switch Output/Input/1.0	199	250	250	100

Chapter 3 Dimension and Structural Diagram

3.1 Dimension Diagram

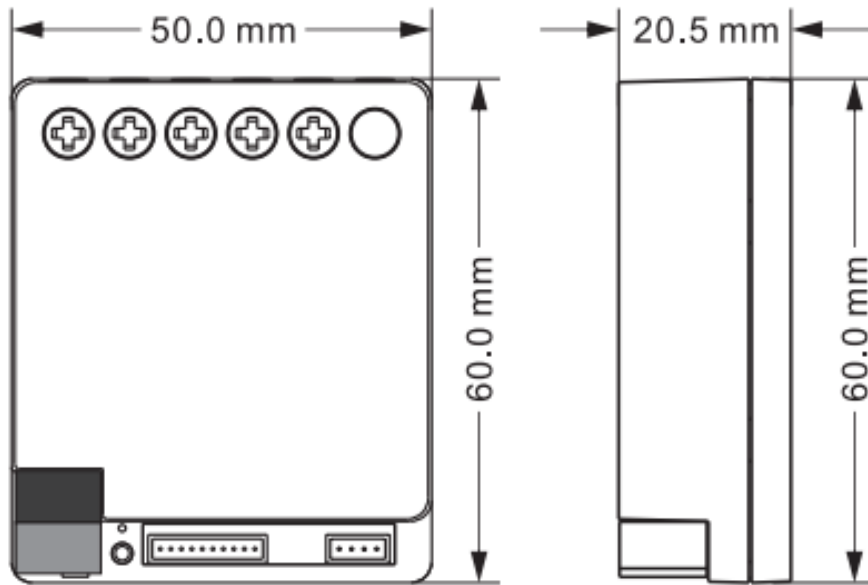

3.2 Structural

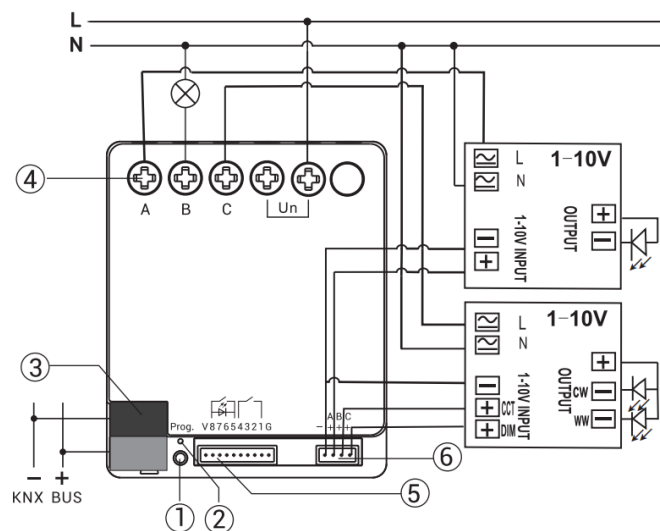

Diagram

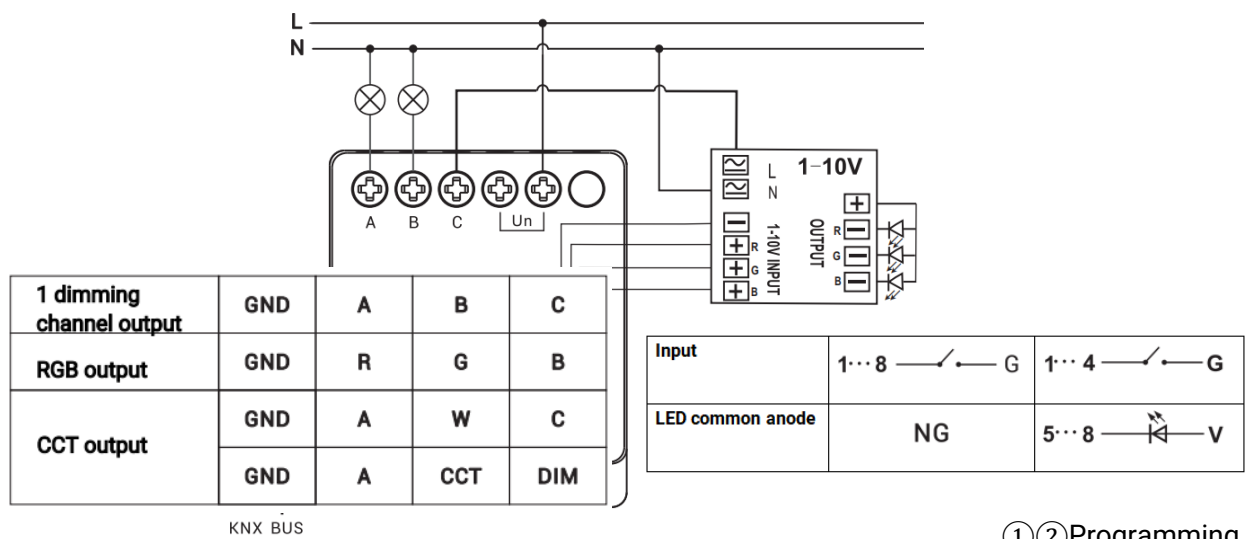

①② Programming

button and LED

- ③ KNX bus terminal
 - ④ Output terminals
 - ⑤ Input/Output LED
 - ⑥ Output 1-10V
- G: GND V: VCC
1..8: Channel 1~8

Note: Reset the device to the factory configuration: press the programming button and hold for 4 seconds then release, repeat the operation for 4 times, and the interval between each operation is less than 3 seconds

Chapter 4 Parameter setting description in the ETS

4.1. KNX Secure

1-10V Dimming Actuator, 3-Fold, Flush Mounted is a KNX device that complies with the KNX secure standard. That is, you can run the device in safe way.

KNX Data Secure

- i KNX Data Secure is available in this device, it effectively protects user data against unauthorised access and manipulation by means of encryption and authentication for the installation.
- i ETS can active or deactivate security function. Detailed specialist knowledge is required.

Device certificate

- i The device certificate label stick called FDSK is attached beside the device, and must use for security function, make sure keep securely.

Fig.4.1 (1) Parameter window "KNX Secure"

The device with KNX secure will be displayed notes on ETS, as shown as Fig.4.1(1).

If secure commissioning is activated in ETS project, the following information must be considered during device debugging:

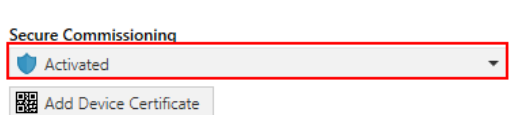

- ❖ It is essential to assign a project password as soon as a KNX Secure device is imported into a project. This will protect the project against unauthorized access.

The password must be kept in a safe place – access to the project is not possible without it (not even the KNX Association or device manufacturer will be able to access it)!

Without the project password, the commissioning key will not be able to be imported.

- ❖ A commissioning key is required when commissioning a KNX Secure device (first download). This key (FDSK = Factory Default Setup Key) is included on a sticker on the side of the device, and it must be imported into the ETS prior to the first download:

- ✧ On the first download of the device, a window pops up in the ETS to prompt the user to enter the key, as shown in Fig.4.1 (2) below.

The certificate can also be read from the device using a QR scanner (recommended).

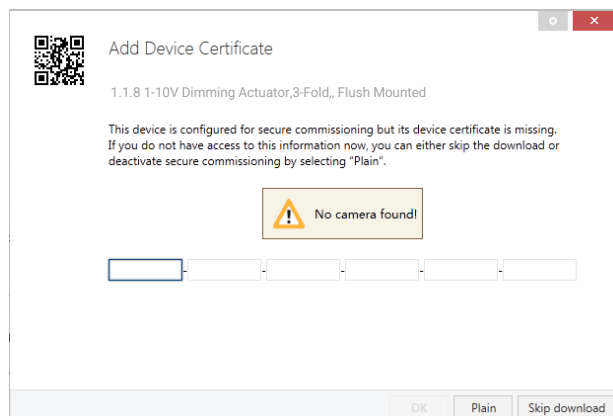

Fig.4.1(2) Add Device Certificate

✧ Alternatively, the certificates of all Secure devices can be entered in the ETS beforehand.

This is done on the "Security" tab on the project overview page, as shown in Fig.4.1(3) below.

The certificates can be also added to the selected device in the project, as shown in Fig.4.1(4).

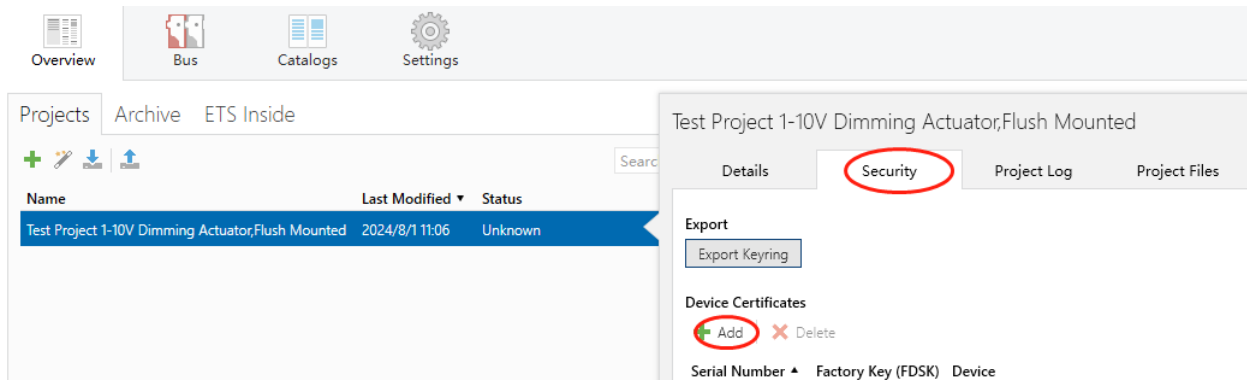

Fig.4.1(3) Add Device Certificate

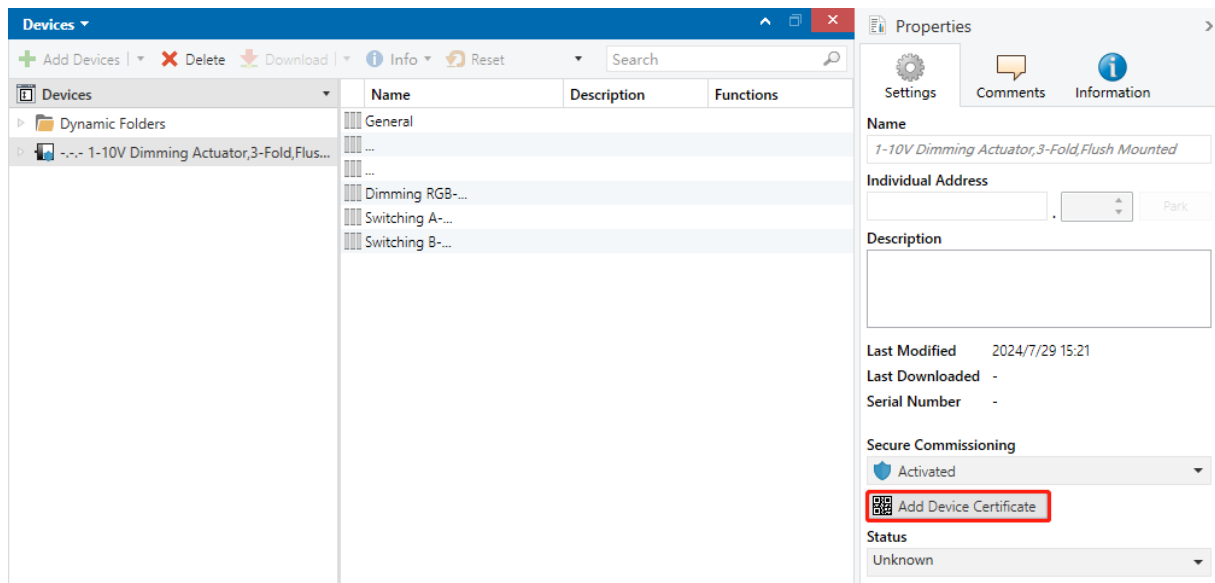

Fig.4.1(4) Add Device Certificate

✧ here is a FDSK sticker on the device, which is used for viewing FDSK number.

Without the FDSK, it will no longer be possible to operate the device in KNX Secure mode after a reset.

The FDSK is required only for initial commissioning. After entering the initial FDSK, the ETS will assign a new key, as shown in Fig.4.1(5) below.

The FDSK will be required again only if the device was reset to its factory settings (e.g. If the device is to be used in a different ETS project).

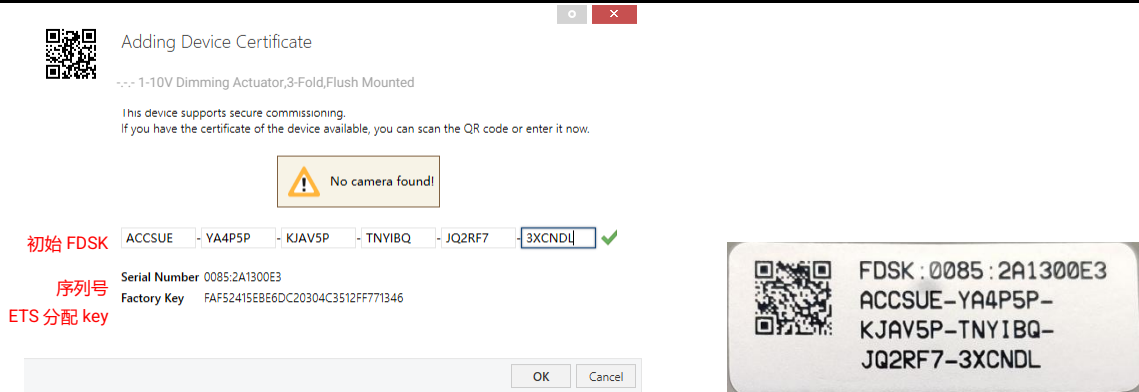

Fig.4.1(5)

Example:

If this application in the project needs to be tried with another device, it is no longer the original device. When the application is downloaded to a new device, the following prompt will appear on the left of Fig.4.1(6), click yes, the Add Device Certificate window will appear, then enter the initial FDSK of the new device, and you need to reset the device to the factory settings (it is not required if the device is still factory default; If it has been used, it will be required to reset, otherwise the following error message will appear on the right of Fig.4.1(6)), and then the device can be successfully downloaded again.

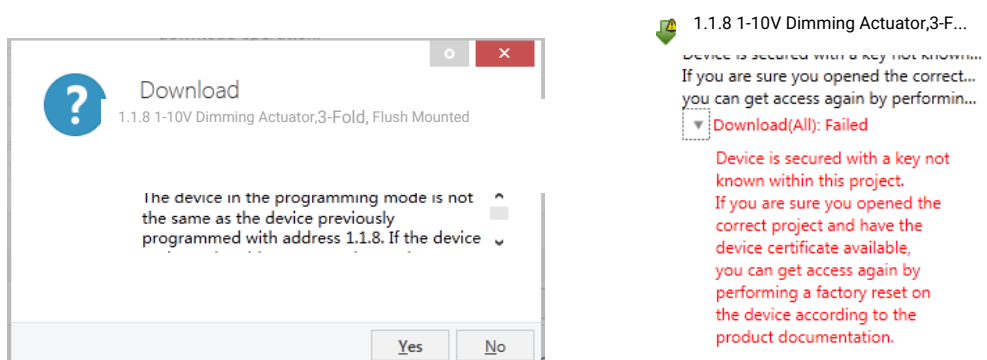

Fig.4.1(6)

Whether the device is replaced in the same project, or the device is replaced in a different project, the processing is similar: **Reset the device to the factory settings, then reassign the FDSK.**

After the device is downloaded successfully, the label Add Device Certificate turns gray, indicating that the key for this device has been assigned successfully, as shown in Fig.4.1(7) below.

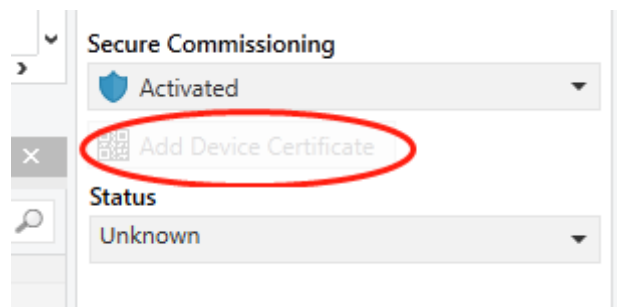

Fig.4.1(7)

ETS generates and manages keys:

Keys and passwords can be exported as needed to the use of security keys outside of the associated ETS projects. As shown in Fig.4.1(8) below, the file extension is .knxkeys.

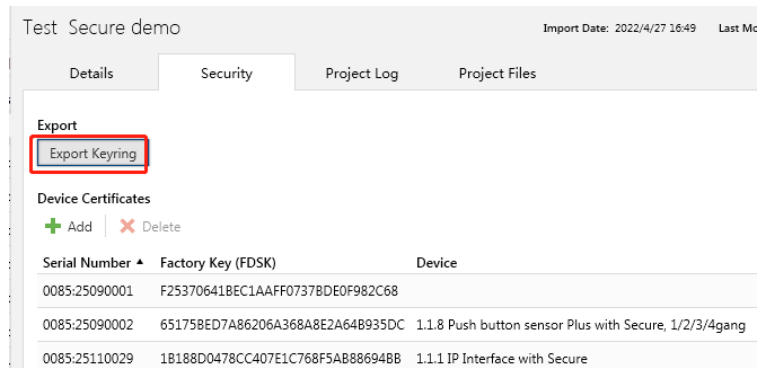

Fig.4.1(8)

Note: Any USB interface used for programming a KNX Secure device must support "long frames". Otherwise ETS will report a download failure information, as shown below.

4.2 Parameter window "General"

Operation and send delay after bus recovery [0..15] s

Send cycle of "In operation" telegram [1..240,0=inactive] s

Safety function

Safety function

Monitoring period [0...1000, 0=monitoring deactive] s

i The safety function is only used to the function of Dimming A, B and C depending to configuration

Fig.4.2 Parameter window "General"

Parameter "Operation and send delay after bus recovery [0..15]"

This parameter is for setting the delay time to send to bus after the device voltage recovery. Options: **0..15s**

The setting dose not contain the device initialization time, and bus telegrams received during delay time will be recorded.

Parameter "Send cycle of "In operation" telegram [1..240,0=inactive]"

This parameter is for setting the time interval when this device cycle send telegrams through the bus to indicate this module in normal operation. When set to "0", the object "in operation" will not send a telegram. If the setting is not "0", the object "In operation" will send a telegram according to the set period time with logic "1" to the bus. Options: **0...240s, 0= inactive**

As to reduce the bus load as much as possible, the maximum time interval should be selected according to actual needs.

Safety function

Parameter "Safety function"

This parameter is for setting the object value of safety status cancellation for whole device, while receiving the reversed value is to enter safety status. Options:

Disable

Cancel via object value "0"

Cancel via object value "1"

When enter safety status, execute the configured behaviour of the channel if its safety function is enabled, more details are defined in the channel.

--Parameter "Monitoring period [0...1000, 0=monitoring deactive]"

This parameter is visible when the previous parameter is enabled. Set the period to monitor the telegram of safety object. Options: **0...1000 s**

If the period is greater than 0, the telegram to cancel safety status was not received during the monitoring period, enter the safety status. Exit this status and reset the monitoring period when a cancellation telegram is received. It is also possible to enter the safety status directly by receiving the reversed value defined by the previous parameter.

If the period is set as 0, enter the safety status directly by receiving the reversed value defined by the previous parameter, and receiving cancellation value is to exit the status.



The safety function is only used to the function of Dimming A, B and C depending to configuration

4.3 Parameter window“Output setting”

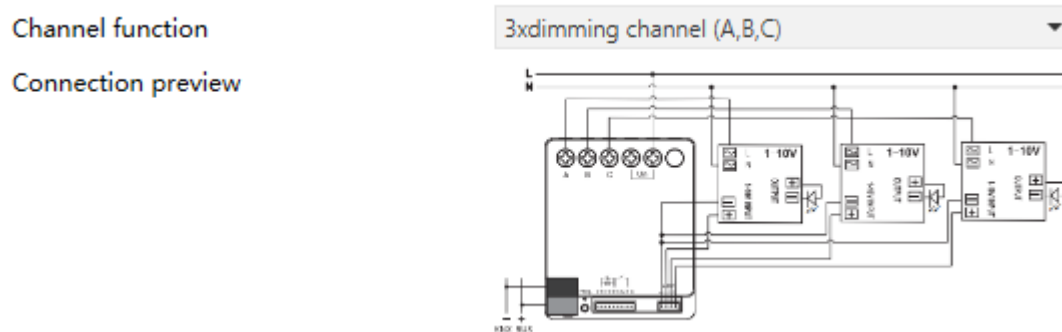

Fig.4.3 Parameter window“Output setting”

Parameter “Channel function”

Select the channel function based on the type of load connected to the output.Options:

- 3 x dimming channel (A, B,C)**
- 1 x switch channel (A)+2 x dimming channel (B, C)**
- 2 x switch channel (A, B)+1 x dimming channel (C)**
- 1 x dimming channel (A)+1 x switch channel (B)+1 x CCT**
- 2 x switch channel (A, B)+1 x CCT**
- 2 x switch channel (A, B)+1 x RGB**

Parameter “Connection preview”

Display the corresponding wiring diagram based on the channel function, as shown in the figure below:

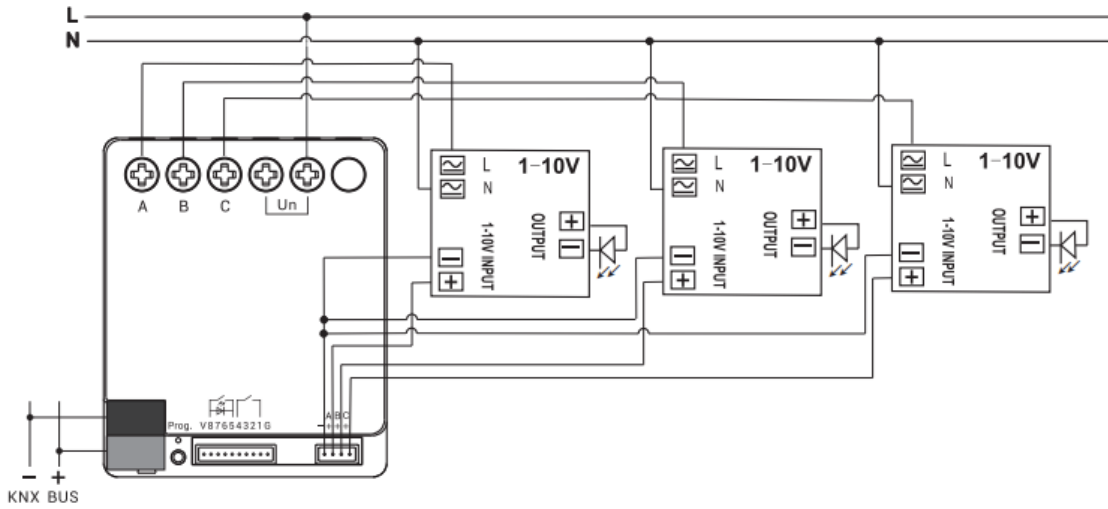

3 x dimming channel (A, B, C)

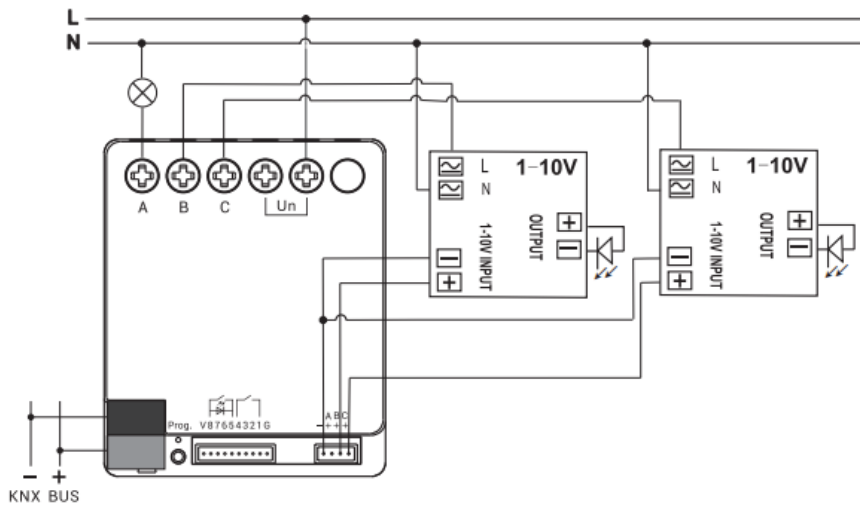

1 x switch channel (A) + 2 x dimming channel (B, C)

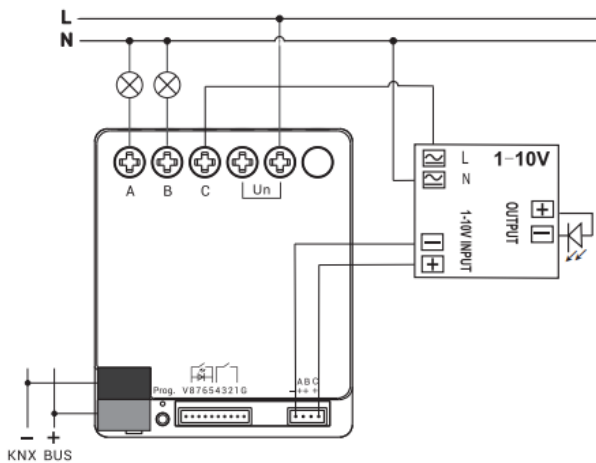

2 x switch channel (A, B) + 1 x dimming channel (C)

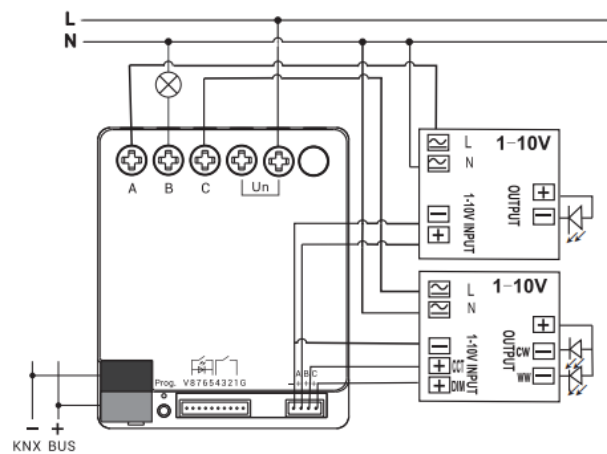

1 x dimming channel (A) + 1 x switch channel (B) + 1 x CCT

4.3.1 Parameter window "Dimming X (X=A,B,C)"

Description (max 30char.)	<input type="text"/>
Dimming curve	User defined <input type="text"/>
<hr/>	
General dimming time (from min. to max.)	4 <input type="text"/> s
Minimum brightness value	1 <input type="text"/> %
Maximum brightness value	100 <input type="text"/> %
<hr/>	
Switching on value	<input type="radio"/> Preset brightness value <input checked="" type="radio"/> Last brightness value
Dimming mode selection for switching on	<input type="radio"/> Jumping <input checked="" type="radio"/> Dimming
Dimming mode selection for switching off	<input checked="" type="radio"/> Jumping <input type="radio"/> Dimming
Dimming time for relative dimming	4 <input type="text"/> s
Dimming time for absolute dimming	4 <input type="text"/> s
Allow switch off via relative dimming	<input checked="" type="checkbox"/>
Absolute dimming value lower than the minimum value	0%=0%, otherwise=Minimum brightness value <input type="text"/>
<hr/>	
Reset behavior	
Behavior after download	<input checked="" type="radio"/> Switching off <input type="radio"/> Preset brightness value
Behavior after bus failure	<input type="radio"/> Switching off <input checked="" type="radio"/> Unchange
Behavior after bus recovery	Preset brightness value <input type="text"/>
Preset brightness value	100 <input type="text"/> %
<hr/>	
Status feedback	
Switching	<input type="radio"/> Respond after read only <input checked="" type="radio"/> Respond after change
Brightness value	<input type="radio"/> Respond after read only <input checked="" type="radio"/> Respond after change

Extension function

Scene function



Time function



Threshold function



Forced function



Safety function



Number of sequence function

1

Fig.4.3.1 Parameter window "Channel"

Parameter "Description (max 30char.)"

This parameter is for setting the name description of the channel, up to input 30 characters.

Parameter "Dimming curve"

This parameter is for setting dimming curve of the channel, display corresponding preview figure below the parameter. Options:

Logarithmic function

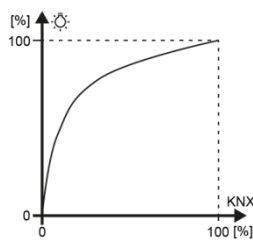

Root function

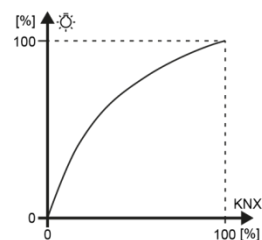

Linear function

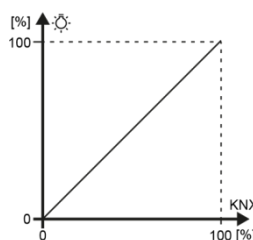

User defined

When "User defined" is selected, user can custom a dimming curve, more detail please refer to chapter 4.3.1.1.

Parameter "General dimming time (from min. to max.)"

This parameter is for setting the time for the whole dimming process, which refers to the time from minimum to maximum value. Suppose the time is set as 6s, the min. Value is 0% and the max. is 100%, if the brightness is only dimmed from 0% to 50%, then the dimming time only takes 3s.

Options: **2...255 s**

If the channel function has not specified a dimming time, use the time set by this parameter, functions such as switch on/off lamps, forced, safety, staircase lighting, threshold, etc.

Parameter "Minimum brightness value"

Parameter "Maximum brightness value"

These parameters are for setting minimum and maximum brightness values individually, to limit the output range of dimming brightness, which is allow the lamps work in a better brightness range depending on the environment or lamps compatibility.

This range is not allowed to be exceeded in any status of lamps on, including threshold, forced, safety functions, etc. Output as min. value when the brightness is lower than the min., and output as max. value when it is higher than the max.

Options of the min. value: **1...49 %**; Options of the max. value: **50...100 %**

Parameter "Switching on value"

This parameter is for setting the brightness when the lamp is switched on. Options:

Preset brightness value

Last brightness value

Last brightness value: When the device is powered on for the first time or restarted after downloading, the default value for "Switch ON" is 50%, meaning the brightness value is 50%.

--Parameter "Preset brightness value"

This parameter is visible when previous parameter is selected "Preset brightness value". Set the preset brightness value. Options: **1...100 %**

Parameter "Dimming mode selection for switching on"

This parameter is for setting the dimming mode when the lamp is switched on. Options:

Jumping

Dimming

Jumping: Switch on immediately and directly to the target brightness.

Dimming: Switch on with dimming to the target brightness and use the General dimming time.

Parameter "Dimming mode selection for switching off"

This parameter is for setting the dimming mode when the lamp is switched off. Options:

Jumping

Dimming

Jumping: Switch off immediately.

Dimming: Switch off with dimming and use the General dimming time.

Parameter "Dimming time for relative dimming"

This parameter is for setting the time for the whole relative dimming process. Options: **2...255 s**

Parameter "Dimming time for absolute dimming"

This parameter is for setting the time for the whole absolute dimming process. Options: **2...255 s**

Parameter "Allow switch off via relative dimming"

This parameter is for setting whether allow to switch lamp off via relative dimming. When disabled, it can only be adjusted downward to the minimum brightness value; while enabled, switch the lamp off directly when the brightness is dimming to less than the minimum brightness value.

Parameter "Absolute dimming value lower than the minimum value"

This parameter is for setting the behaviour when absolute dimming value less than the minimum value, **it only affects the object "Absolute dimming"**. Options:

0%=0%, otherwise=Minimum brightness value

To be the minimum brightness value

To be 0%

0%=0%, otherwise=Minimum brightness value%: Output as min. value when the value is less than the min., but the value is 0% is to switch the lamp off.

To be the minimum brightness value: Output as min. value when the value is less than the min., even if the value is 0%.

To be 0%: Switch the lamp off directly when the value is less than the min.

Reset behavior

Parameter "Behavior after download"

This parameter is for setting the behaviour of channel after download. Options:

Switching off

Preset brightness value

Preset brightness value: dimming to a setting brightness, defined by next parameter.

--Parameter "Preset brightness value"

This parameter is visible when "Preset brightness value" is selected. Set the preset brightness value. Options: **1...100 %**

Parameter "Behavior after bus failure"

This parameter is for setting the behaviour of channel after bus failure. Options:

Switching off

Unchange

Parameter "Behavior after bus recovery"

This parameter is for setting the behaviour of channel after bus recovery.

Switching off

Preset brightness value

Brightness before bus failure

Preset brightness value: Dimming to a setting brightness, defined by next parameter.

Brightness before bus failure: Recover to the brightness value stored when the bus failure.

--Parameter "Preset brightness value"

This parameter is visible when "Preset brightness value" is selected. Set the preset brightness value. Options: **1...100 %**

Status feedback

Parameter "Switching/Brightness value"

These parameters are for setting the way to feed back the status of switch and brightness status.

Options:

Respond after read only

Respond after change

Extension function

Parameter "Scene function"

Setting page of scene function interface is visible after this parameter enabled. For detailed operations, refer to section 4.3.1.2.

Parameter "Time function"

Setting page of time function interface is visible after this parameter enabled. For detailed operations, refer to section 4.3.1.3.

Parameter "Threshold function"

Setting page of threshold function interface is visible after this parameter enabled. For detailed operations, refer to section 4.3.1.4.

Parameter "Forced function"

Setting page of forced function interface is visible after this parameter enabled. For detailed operations, refer to section 4.3.1.5.

Parameter "Safety function"

Setting page of safety function interface is visible after this parameter enabled. For detailed operations, refer to section 4.3.1.6.

Parameter "Number of sequence function"

This parameter is for setting the number of sequences to be enabled, and the corresponding parameter interface is visible after enabling. Options: **None/1/2/3/4**

For detailed operations, refer to section 4.3.1.7.

4.3.1.1 Parameter window “User defined dimming curve”

Number of curve coordinate points	<input type="text" value="4"/>
Coordinate point 1	
KNX dimming value	<input type="text" value="1"/> %
Output value	<input type="text" value="1"/> %
Coordinate point 2	
KNX dimming value	<input type="text" value="10"/> %
Output value	<input type="text" value="10"/> %
Coordinate point 3	
KNX dimming value	<input type="text" value="20"/> %
Output value	<input type="text" value="20"/> %
Coordinate point 4	
KNX dimming value	<input type="text" value="100"/> %
Output value	<input type="text" value="100"/> %

Fig.4.3.1.1Parameter window “User defined dimming curve”

Parameter “Number of curve coordinate points”

This parameter is for setting the number of curve coordinate points. Options: **2...5**

Coordinate point x (x=1~5)

Parameter “KNX dimming value”

This parameter is for setting KNX dimming value of the curve. Options: **1..100%**

For user defined dimming curve, the first and the last one points are fixed to 1% and 100%.

Note: the previous KNX dimming value must be small than next one, otherwise it cannot be set on the ETS:

Coordinate point 2

KNX dimming value %

Output value %

Coordinate point 3

KNX dimming value %

Output value %

Parameter "Output value"

This parameter is for setting the output value corresponding to the KNX dimming value.

Options: 1..100%

Note: the previous output value must be small than next one, otherwise it cannot be set on the

ETS:

Coordinate point 2

KNX dimming value %

Output value %

Coordinate point 3

KNX dimming value %

Output value %

Custom curves with different number of coordinate points, as shown as following:

Example 1

(3 coordinate points)

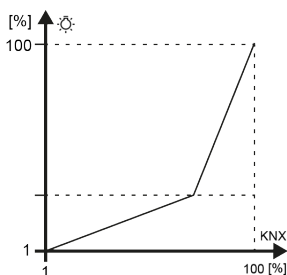

Example 2

(4 coordinate points)

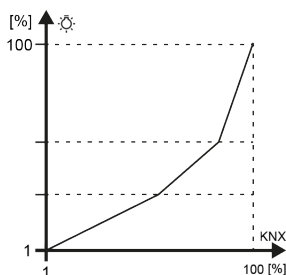

Example 3

(5 coordinate points)

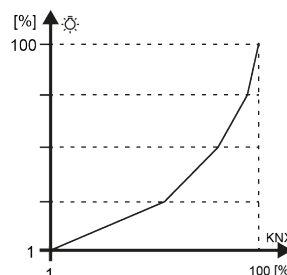

Commissioning steps of User defined dimming curve:

Step 1: Use the linear function curve at first to determine the adjustable range, then obtain the minimum and maximum adjustable brightness values of the applied lamp with absolute dimming;

Step 2: When testing in step 1, you can experience the brightness changes with relative dimming, then checking the number of curve areas and coordinate points;

Step 3: The minimum brightness value is the point of knx value 1%, the maximum brightness

value is the point of KNX value 100%;

Step 4: Add the coordinate points of the middle section according to the planning area;

Step 5: Download and commission, according to the experience of dimming process, there may also be slight adjustment of the coordinate points or increase the configuration areas, and even need to adjust the dimming time, until achieve the best results for user satisfaction.

4.3.1.2 Parameter window“Scene function”

Overwrite scene stored values during download



Scenes	Description	Scene NO.	Brightness	Dimming
Scene 1		1	50 %	4 s
Scene 2		0	NA	NA
Scene 3		0	NA	NA
Scene 4		0	NA	NA
Scene 5		0	NA	NA
Scene 6		0	NA	NA
Scene 7		0	NA	NA
Scene 8		0	NA	NA
Scene 9		0	NA	NA
Scene 10		0	NA	NA
Scene 11		0	NA	NA
Scene 12		0	NA	NA
Scene 13		0	NA	NA
Scene 14		0	NA	NA
Scene 15		0	NA	NA
Scene 16		0	NA	NA

Fig.4.3.1.2 Parameter window“Scene function”

Scene function can work with the control panel or other software to execute the setting scene and output the specified brightness.

Parameter “Overwrite scene stored values during download”

This parameter is for setting whether to overwrite the scene stored values during application download. If select to overwrite, follow the parameter setting, otherwise for the brightness value corresponding to the scene number that has saved the modified value has executed, the last saved value will remain; for the modified brightness has not executed, still use the value set by parameter.

Scene x (x=1~16)

Parameter “Description”

This parameter is for setting the name description of the corresponding scene, up to 30 characters.

Parameter “Scene NO.”

This parameter is for setting the triggered scene number, up to 16 scenes. Options: **0...64**

When scene number is 0, it is invalid, and the brightness and dimming time cannot be set, as shown as following:

Scenes	Description	Scene NO.	Brightness	Dimming
Scene 1		0	NA	NA

When scene numbers are greater than 0, if there are same scene numbers, display following error message:

 Exist multiple scene NO. assignment conflict, the valid scene NO. can't be the same, please correct, otherwise only the first one of those conflict scene is valid and others will be ignored

Parameter “Brightness”

This parameter is for setting the brightness of the corresponding scene. Options: **0...100 %**

Parameter “Dimming”

This parameter is for setting the dimming time of the corresponding scene. Options: **2...255 s**

4.3.1.3 Parameter window "Time function"

Time function	Delay switch	
Delay for switch on	00:00:10	hh:mm:ss
Delay for switch off	00:00:10	hh:mm:ss
	Delay switch	
Time function	Flashing switch	
On time for flashing	00:00:10	hh:mm:ss
Off time for flashing	00:00:10	hh:mm:ss
Number of flashing cycles [0..10000,0=no limit]	0	
Status after flashing	Unchange	
Control mode of flashing	Start with "1", Stop with "0"	
	Flash switch	
Time function	Staircase lighting	
Duration time	00:02:00	hh:mm:ss
Time extension	Retriggerable	
Control mode of staircase lighting	Start with "0/1", can not be stopped	
Prewarning before staircase time end	Dim-down the dimming value	
Warning time	00:00:30	hh:mm:ss
Value of dimming down	20	%
Duration time can be changed via bus	<input checked="" type="checkbox"/>	

i The duration time receiving from bus must be longer than the warning time, otherwise it will be ignored

Staircase lighting

Fig.4.3.1.3 Parameter window "Time function"

Different configurations of time function can be used for different application.

This parameter is for setting the time function, its brightness is depending on the value of switch on/off. Options:

Delay switch

Flashing switch

Staircase lighting

Delay switch: Delay a period time to switch on/off, dimming mode is Jumping.

Flashing switch: Flashing to switch on/off, dimming mode is Jumping.

Staircase lighting: Switch on/off, dimming mode is Jumping; dim-down to dimming value, use the General dimming time.

Note: time function will be interrupted directly after entering safety or forced operation.

Parameters as follow are visible when "Delay switch" is selected.

Parameter "Delay for switch on"

Parameter "Delay for switch off"

This parameter is for setting the delay time for switch on/off, execute the on/off telegram received from bus after the delay has elapsed. During delay time, receive the same telegram again, the delay time is reset.

Options: **00:00:00 ...23h:59min:59s**

Parameters as follow are visible when "Flashing switch" is selected.

Parameter "On time for flashing"

Parameter "Off time for flashing"

This parameter is for setting the duration time of flashing for switch on/off.

Options: **00:00:01s ...23h:59min:59s**

Parameter "Number of flashing cycles [0..10000,0=no limit]"

This parameter is for setting the number of flashing cycles, a cycle includes an on and an off. 0 means the cycles is no limited. Options: **0...10000**

Parameter "Status after flashing"

This parameter is for setting the status after flashing. Options:

Switching off

Switching on

Unchange

Note: There is a possibility of an extra half cycle of action when "Switching on" or "Switching off" is selected.

Parameter "Control mode of flashing"

This parameter is for setting the control mode of flashing. Options:

Start with "1", Stop with "0"

Start with "0", Stop with "1"

Start with "0/1", can not be stopped

Start with "1", Stop with "0": It will start flashing with value "1" and stop flashing with "0", action to the end status when stopped, which is defined via previous parameter.

Start with "0", Stop with "1": It will start flashing with value "0" and stop flashing with "1", action to the end status when stopped, which is defined via previous parameter.

Start with "0/1", can not be stopped: It will start flashing with value "0" or "1", and can not stop until the number of the flashing cycles is exhausted, or stop via the interruption from other operation.

Parameters as follow are visible when "Staircase lighting" is selected.

Parameter "Duration time"

This parameter is for setting the duration time of staircase lighting switch on, and switch off automatically after the time has elapsed.

Options: **00:00:05s ...23h:59min:59s**

Parameter "Time extension"

This parameter is for setting whether to retrigger or extend the duration time when receive an on telegram during the time. Options:

Not retriggerable

Retriggerable

Extend duration time

Not retriggerable: Ignore the telegram, switch off automatically after the time has elapsed.

Retriggerable: Retrigger the duration time when receive an on telegram during the time.

Extend duration time: Add up a duration time to the remaining time when receive an start telegram during the duration time. For example the duration time is set as 60s, but it is still has 40s left, and receive an on telegram at the moment, then the new duration time is 40s+60s =100s, and the staircase light will be turned off automatically after the 100s is elapsed. If receive multiple start telegrams continuously, the duration time will continue to add up until the maximum time is reached.

Parameter "Control mode of staircase lighting"

This parameter is for setting the control mode of staircase lighting. Options:

Start with "1", Stop with "0"

Start with "1", no reaction with "0"

Start with "0/1", can not be stopped

Start with "1", Off with "0"

Start with "1", Stop with "0" : It will switch on the staircase light with the value "1" and stop the timing with "0", keep the current lamps status until it is changed by other operations.

Start with "1", no reaction with "0": It will switch on the staircase lights with the value "1" and no reaction with "0".

Start with "0/1", can not be stopped: It will switch on the staircase lights with the value "1" or "0", and can not stop until the duration time is exhausted, or stop via the interruption from other operation.

Start with "1", Off with "0": It will switch on the staircase lights with the value "1" and switch off with "0".

Parameter "Prewarning before staircase time end"

This parameter is for setting whether to prewarn before staircase light time end, and set the prewarning mode. User can receive prewarning before staircase time end. Options:

No

No, but dim-down the dimming value after end

Via object

Via flashing switching on-off

Via flashing switching on-off and object

Dim-down the dimming value

Dim-down the dimming value and via object

No: No prewarn, and switch off automatically after the time has elapsed.

No, but dim-down the dimming value after end: No prewarn, but dim down the brightness after the time has elapsed.

Via object: Prewarn via the object.

Via flashing switching on-off: Prewarn via a short flashing, 1s to switch on and 1s to switch off, dimming mode is Jumping.

Via flashing switching on-off and object: Prewarn, refer to the explanation of the previous options.

Dim-down the dimming value: Prewarn via dimming down the brightness.

Dim-down the dimming value and via object: Prewarn, refer to the explanation of the previous options.

--Parameter "Warning time"

This parameter is visible when the selection does not contains "No...". Set the warning time .

Options: **00:00:05s...00h:59min:59s**

Note: the warning time must be less than the duration time, or it cannot set on the ETS.

Note: the warning time is contained in the startup time of staircase lighting. If switch off before the warning time, there is no prewarning.

--Parameter "Value of dimming down"

This parameter is visible when the selection contains "Dim-down the dimming value...". Set the brightness value of dimming down at the end of the staircase lighting. Options: **1...100 %**

Parameter "Duration time can be changed via bus"

This parameter is for setting whether the duration time can be changed via bus. Store the modified value when bus failure, recovery to the value set by parameter after download.

i The duration time receiving from bus must be longer than the warning time, otherwise it will be ignored

4.3.1.4 Parameter window "Threshold function"

Threshold value datatype	illuminance (DPT9.004)	▼
Threshold value 1	50	▲▼ lux
Threshold value 2	250	▲▼ lux
Threshold can be changed via bus	<input type="checkbox"/>	
Threshold behavior	<input type="radio"/> Without hysteresis	<input checked="" type="radio"/> With hysteresis
Output type	<input checked="" type="radio"/> Switching	<input type="radio"/> Brightness value
If input value <= threshold value 1		
Output is	Switching on ▼	
If threshold value 1 < input value < threshold value 2		
Output is	Unchange	
If input value >= threshold value 2		
Output is	Switching off ▼	

Fig.4.3.1.4 Parameter window "Threshold function"

Switch on/off or dimming the brightness according to telegram from the bus and threshold set on the ETS.

Note: the brightness of threshold function is depending on the value of switch on/off.

Parameter "Threshold value datatype"

This parameter is for setting the threshold value datatype. Options:

- 1byte unsigned value (DPT5.010)**
- 1byte percentage (DPT5.001)**
- Temperature (DPT9.001)**
- Illuminance (DPT9.004)**

Parameter "Threshold value 1"

Parameter "Threshold value 2"

These two parameters are for setting the threshold value 1 and 2. Options are display according to the threshold value datatype.

When 1byte unsigned value, options: **0...255**

When 1byte percentage, options: **0...100 %**

When Temperature, options: **-20...95 ° C**

When Illuminance, options: **0...65535 lux**

Note: the threshold 1 must be less than threshold 2, or they cannot be set on the ETS, as shown as following:

Threshold value 1

Threshold value 2

Parameter "Threshold value can be changed via bus"

This parameter is for setting whether the threshold 1 and 2 can be changed via bus.

Store the modified value when bus failure, recovery to the value set by parameter after download.

Parameter "Threshold behavior"

This parameter is for setting whether the threshold 1 and 2 with hysteresis. Options:

Without hysteresis

With hysteresis

The hysteresis can avoid the unnecessary behaviour caused by the input value if the value is between two threshold values.

Parameter "Output type"

This parameter is for setting the output type after threshold comparison. Options:

Switching

Brightness value

If input value<=threshold value 1

Set the output value when input value is less than or equal to the threshold 1. Following parameter and its options are displayed according to the output type.

--Parameter "Output is"

This parameter is visible when "Switching" is selected. Options:

Switching off

Switching on

Unchange

--Parameter "Dimming value is"

This parameter is visible when "Brightness value" is selected. Options: **0...100 %**

If threshold value 1<input value<threshold value 2

Set the output value when input value is between the threshold 1 and 2. Output parameter and its options are displayed according to the output type, as above explanation.

Note: when with hysteresis, the output is only **Unchange**

If input value>=threshold value 2

Set the output value when input value is greater than the threshold 2. Output parameter and its options are displayed according to the output type, as above explanation.

4.3.1.5 Parameter window "Forced function"

Forced operation datatype	<input checked="" type="radio"/> 1bit <input type="radio"/> 2bit
Forced operation at object value	<input type="radio"/> 0=Forced/1=Cancel <input checked="" type="radio"/> 1=Forced/0=Cancel
Behavior at forced operation	Preset brightness value
Preset brightness value	100 %
Behavior at end of forced operation	Unchange
	1bit
Forced operation datatype	<input type="radio"/> 1bit <input checked="" type="radio"/> 2bit
Behavior at forced operation "switch on"	<input checked="" type="radio"/> Preset brightness value <input type="radio"/> Unchange
Preset brightness value	100 %
Behavior at forced operation "switch off"	Switching off
Behavior at end of forced operation	Unchange
	2bit

Fig.4.3.1.5 Parameter window "Forced function"

The forced function can force the lamp at a preset brightness in some special situations. Forced function has the highest priority. Ignore the normal control telegram received from bus when during in forced or safety operation.

Parameter "Forced operation datatype"

This parameter is for setting the datatype of forced operation. Options:

1bit

2bit

Parameter "Forced operation at object value"

This parameter is visible when 1bit. Set the object value for activating or canceling the forced.

Options:

0=Forced/1=Cancel

1=Forced/0=Cancel

Parameter "Behavior at forced operation"

This parameter is visible when 1bit. Set behavior at forced operation. Options:

Switching off

Preset brightness value

Unchange

Preset brightness value: dimming to a setting brightness, defined by next parameter

--Parameter "Preset brightness value"

This parameter is visible when "Preset brightness value" is selected. Set the preset brightness value. Options: **1...100 %**

Parameter "Behavior at forced operation "switch on""

This parameter is visible when 2bit. Set the behavior at forced operation "switch on" when receive telegram "3" . Options:

Preset brightness value

Unchange

--Parameter "Preset brightness value"

This parameter is visible when "Preset brightness value" is selected. Set the preset brightness value. Options: **1...100 %**

Parameter "Behavior at forced operation "switch off""

This parameter is visible when 2bit. Set the behavior at forced operation "switch off" when receive telegram "2" . Option is only **Switching off**

Parameter "Behavior at end of forced operation"

This parameter is for setting the behavior at end of forced operation.

Note: the telegram values 0/1 from 2bit are used to cancel forced operation.

Options:

Switching off

Preset brightness value

Unchange

1.When receive a telegram to end forced operation, it is valid if the forced operation has been

activated before, otherwise ignore the telegram.

2. When a telegram to end forced operation is valid, if there is another priority (safety operation) active in the device, execute this action of this priority; otherwise, ignore the end telegram and execute the action of forced operation.

--Parameter "Preset brightness value"

This parameter is visible when "Preset brightness value" is selected. Set the preset brightness value. Options: **1...100 %**

4.3.1.6 Parameter window "Safety function"

Behavior at safety operation	Preset brightness value
Preset brightness value	100 %
Behavior at end of safety operation	Unchange

Fig.4.3.1.6 Parameter window "Safety function"

Safety function can work with external sensor and perform dimming behaviour in some emergency situations. Safety function has the second highest priority and only lower than forced function.

Parameter "Behavior at safety operation"

Parameter "Behavior at end of safety operation"

These two parameters are for setting the behavior for activating or canceling the safety operation. Options:

Switching off

Preset brightness value

Unchange

Preset brightness value: dimming to a setting brightness, defined by next parameter.

--Parameter "Preset brightness value"

This parameter is visible when "Preset brightness value" is selected. Set the preset brightness value. Options: 1...100 %

1. When receive an end telegram, it is valid if the safety operation has been activated before, otherwise ignore the telegram.

2. When the end telegram is valid, if there is another priority (forced operation) active in the device, execute this action of this priority; otherwise, ignore the cancel telegram and execute the action of safety operation.

4.3.1.7 Parameter window "Sequence X (X=1~4)"

Description (max 30char.)	<input type="text"/>
Work mode	Breathing ▼
Assign Scene NO. to start sequence [1..64,0=no assignment]	0 ▲▼
Number of sequence execution (0=no limit)	1 ▲▼
Behavior after the end	Switching off ▼
Additional behavior when receiving a sequence "stop" telegram	<input checked="" type="radio"/> Switching off <input type="radio"/> Unchange
Behavior when receiving a switch on/relative dimming/absolute dimming telegram	<input type="radio"/> Ignore, and keep running <input checked="" type="radio"/> Stop running
Behavior when receiving a switch "OFF" telegram	<input checked="" type="radio"/> Switching off and stop sequence <input type="radio"/> Ignore, and keep running
<hr/>	
Number of step	7 ▼
Step 1	
Brightness value	100 ▲▼ %
Pause time	0 ▲▼ s
Breathing time of the next step	4 ▲▼ s
Step 2	
Brightness value	100 ▲▼ %
Pause time	0 ▲▼ s
Breathing time of the next step	4 ▲▼ s

Fig.4.3.1.7 Parameter window "Sequence X-{{0:...}},(X=1~4)"

Parameter "Description (max 30char.)"

This parameter is for setting the name description of the sequence, up to input 30 characters.

Parameter "Work mode"

This parameter is for setting the lamps work mode for the sequence. Options:

Breathing

Jumping

Dimming

Parameter "Assign Scene NO. to start sequence [1..64,0=no assignment]"

This parameter is for setting the assign scene number to start sequence. Options: **0..64**

Note: When 2 or more sequences are configured to conflict, the first conflicting scene is executed and the others scenes are ignored.

Parameter "Number of sequence execution (0=no limit)"

This parameter is for setting the number of sequence execution. Options: **0...255**

0: Unlimited cyclic sequences, unless interrupted by sequence start/stop objects or other control commands.

1: An acyclic sequence that is executed only once.

2..255: Loop sequence, after the last parameter step, the sequence will restart until the loop count is reached, ending the sequence.

Parameter "Behavior after the end"

In the case of a sequence with a limited loop running, sets the behavior after the end. Options:

Switching off

Start Sequence 1/2/3/4

Unchange

Sequence 1/2/3/4: When "Number of sequence executions" is greater than 1, it is visible. After the current sequence finishes running, continue with running another sequence, x.

Parameter "Additional behavior when receiving a sequence "stop" telegram"

This parameter is for setting the behavior when receiving a sequence "stop" telegram. Options:

Switching off

Unchange

Parameter "Behavior when receiving a switch on/relative dimming/absolute dimming telegram"

This parameter is for setting the sequence behavior when receiving a "switch on/relative dimming/absolute dimming" telegram.

When the lamps work mode is breathing, Options: **Ignore, and keep running/Stop running**

When the lamps work mode is "jumping" or "dimming", Options:

Execute and update step preset value, and keep running

Execute and not update step preset value, and keep running

Ignore, and keep running

Stop running

Note: 1.The sequence stop running when it receives a command for a extension function, such as scene, time, threshold, forced, safety.

2.When a "0" command is received, the sequence will only be executed and not saved.

Parameter "Behavior when receiving a switch "OFF" telegram"

This parameter is for setting the sequence behavior when receiving a switch "OFF" telegram.Options:

Switching off and stop sequence

Ignore, and keep running

Switching off and stop sequence: Switching off the lamp and stop sequence when receiving a switch "OFF" telegram.

Ignore, and keep running: Ignore and keep running sequence when receiving a switch "OFF" telegram.

Parameter "Number of step"

This parameter is for setting the number of steps for the sequence to run, up to7.Options: **1...7**

Note: There is no option "1" when "Dimming" and "Jumping" are selected for the lamp work mode.

Parameter "Brightness value"

This parameter is for setting the lamp brightness value.Options: **1...100%**

Parameter "Pause time"

When "Breathing" is selected for work mode, this parameter sets the pause time after the lamp of the current step is adjusted to the minimum brightness, and then adjust the brightness again to the target brightness value of the next step (this time is counted after the breathing period).

When "Jump" is selected for work mode, this parameter sets the pause time after switching to the target brightness value, and then immediately switch to the target brightness value of the next step.

When "Dimming" is selected for work mode, this parameter sets the pause time after reaching the target brightness value before starting to fade to the next target brightness value.

Options: 0...14400s

Parameter "Breathing time of the next step"

This parameter is visible when "Breathing" is selected. Set breathing time of the next step. This refers to the time of gradual change from the lowest brightness to the target value, and then from the target value to the lowest brightness. Options: 2.... .255s

Note: step1 is regulated at the start-up run of the sequence using the general dimming time until the next step which uses the breathing time set by this parameter, or if during the cycling of the sequence, the breathing time of step1 is determined by the definition of the parameter in the previous step (the last step of this or any other sequence).

Parameter "Transition time to the next step"

This parameter is visible when "Dimming" is selected. Set the dimming time from the current step's target brightness value to the next step's target brightness value (this time is counted after the pause time).

Note: When the sequence starts, step1 uses the general dimming time to adjust the target brightness value.

4.3.2 Parameter window "Switch X (X=A,B)"

The switch outputs have a maximum of 2-fold output channels. Since the parameter and

communication object assigned to each fold output are the same, a one-fold output is taken as an example.

The parameter setting interface "Switch" is shown in Figure 4.3.2(1) The setting of this interface acts on the entire channel of the relay. In addition to setting the commonly used switching functions, it can also set the reply mode of switch status.

Description (max 30char.)	<input type="text"/>
If bus recovery,output status is	Contact open ▼
If bus failure,output status is	Contact open ▼
After downloading,output status is	<input checked="" type="radio"/> Contact open <input type="radio"/> As bus recovery
Set the reply mode of switch status	<input type="radio"/> Respond after read only <input checked="" type="radio"/> Respond after change
Object value of switch status	<input type="radio"/> 0=contact close;1=contact open <input checked="" type="radio"/> 1=contact close;0=contact open
Output status for the telegram "1" (telegram "0" is opposite of selection)	<input type="radio"/> Contact open <input checked="" type="radio"/> Contact close
Extension function	<input checked="" type="checkbox"/>

Fig.4.3.2(1) Parameter window"Switch"

Parameter "Description(max 30char.)"

This parameter is used to set the custom description of channel, up to input 30 characters.

Parameter "If bus recovery,output status is"

The parameter sets the position of the relay contacts when the bus recovery. Options:

- Unchange**
- Contact open**
- Contact close**
- As before as bus fail**

Unchange: The contact will not change when bus recovery.

Contact open: The contact will be opened when bus recovery.

Contact close: The contact will be closed when bus recovery.

As before as bus fail: The contact position when bus recovery is the same as that before bus failure.

Parameter "If bus failure, output status is"

The parameter sets the position of the relay contacts when the bus failure.. Options:

- Unchange**

Contact open

Contact close

Unchange: The contact will not change when bus failure.

Contact open: The contact will be opened when bus failure.

Contact close: The contact will be closed when bus failure.

Parameter "After downloading, output status is"

This parameter set the contact position of the relay contacts after downloading. Options:

Contact open

As bus recovery

Contact open: The contact will be opened after application downloading.

As bus recovery: The contact will action according to the setting of parameter "If bus recovery, contact is" after application downloading.

Parameter "Set the reply mode of switch status"

This parameter defines how to respond the current switch status to the bus. There are two options to select. Options:

Respond after read only

Respond after change

Respond after read only: The status telegram will not be sent out until receiving a read request telegrams via the object "reply switch status" from the bus.

Respond after change: When switch status of the channel changes, object "switch status" will immediately send the current report telegram to the bus.

Parameter "Object value of switch status"

Options:

0=contact close; 1=contact open

1=contact close; 0=contact open

0=contact close ; 1=contact open: The value of object "switch status" is 0 indicates the contact of the relay will be closed; when is 1, indicates the contact of the relay will be open.

1=contact close; 0=contact open: Indicates the opposite meaning.

Note: After programming or system reset, the switch status is determined, the object "switch status" will send status messages to the bus; if not, it will not be sent.

Parameter "Output status for the telegram" 1 "(telegram "0" is opposite of selection)"

This parameter defines the contact position when switch on, which will be triggered by the communication object "switch". When enabling "input 0" in the logic function, it will use the communication object "switch" to modify the value of "input 0", rather than triggering the switch operation. In this case, this parameter setting is no significance. Options:

Contact open

Contact close

Contact open: The contact will be opened when receive telegram "1", telegram "0" is opposite.

Contact close: The contact will be closed when the telegram "1", telegram "0" is opposite.

Note: When the logic function input 0 enables, the object "switch" used as input of input 0, the operation of general switch will become invalid.

Parameter "Extension function "

This parameter defines whether enable the extension function, The parameter setting interface "Function" will be seen when select "Enable", and able to set the special functions individually in Fig. 4.3.2(2).

Function of "Time"	<input type="checkbox"/>
Function of "Logic"	<input type="checkbox"/>
Function of "Scene"	<input type="checkbox"/>
Function of "Forced"	<input type="checkbox"/>
Function of "Operation hours counter"	<input type="checkbox"/>

Fig.4.3.2(2) Parameter window"Function"

4.3.2.1 Parameter window"Time"

This parameter window is visible when selecting "enable" in the parameter "Function of 'time'" in the window "Function" shown in Fig. 4.3.2(2). See Fig. 4.3.2.1. And the object "enable time function" will be also visible, which is used to disable the time function. After disabled, clear the current timer, stop running and ignore the delayed operation.

Type of time function

Fig.4.3.2.1 Parameter window"Time"

Parameter "Type of time function"

The parameter defines the type of the time function, there are three options for the mode of work.

Options:

- Delay**
- Flashing**
- Staircase**

4.3.2.1.1 "Delay"

The parameter window "Type of time function-Delay" setting interface in Fig. 4.3.2.1.1 will be shown when selecting "Delay". The delay switch can be started via the object "Delay function".

Type of time function	<input type="text" value="Delay"/>
Delay for switch on(contact close) --[0..240]	<input type="text" value="0"/> min
--[0..59]	<input type="text" value="0"/> s
Delay for switch off(contact open) --[0..240]	<input type="text" value="0"/> min
--[0..59]	<input type="text" value="0"/> s

Fig.4.3.2.1.1 Parameter window "Type of time function"

Parameter "Delay for switch on(contact close):--[0...240]min/[0...59]s"

This parameter defines the delay time of switching on. Options:

0...240 Minutes

0...59 Seconds

Setting the delay time to switch on when object receive the control telegram.

Parameter "Delay for switch off(contact open):--[0...240]min/[0...59]s"

This parameter defines the delay time of switching off. Options:

0...240 Minutes

0...59 Seconds

Setting the delay time to switch off when object receive the control telegram.

If receiving the re-trigger telegram again during delay, the delay will be reset.

4.3.2.1.2 "Flashing "

The parameter window "Type of time function-Flashing" setting interface in Fig. 4.3.2.1.2 will be shown up when selecting "Flashing" in the parameter "Type of time function". The flashing switch function is mainly used for lamp aging test.

Type of time function	Flashing
Duration of switch on(contact close) --[0..240]	0 min
--[0..59]	5 s
Duration of switch off(contact open) --[0..240]	0 min
--[0..59]	5 s
Number of ON-impulsed (1..255,0=no limited)	0
Output status after flashing	Unchange
Control mode of flashing	Start with "1",Stop with "0"

Fig.4.3.2.1.2 Parameter window"Type of time function - Flashing"

Flashing function can be started via the object "Flashing function". It is able to set the flashing

time in “Duration of switch on” or “Duration of switch off”, which will restart the flashing when receiving the start flashing telegram, and define the contact position after flashing.

Parameter “Duration of switch on: --[0...240]min/[0...59]s”

This parameter defines the duration of the switch on the output when flashing. Options:

0...240 minutes

0...59 seconds

Note:1. It will not be executed unless the time is lower than the relay threshold switch frequency. Since there will be not sufficient energy to do it because of the frequent relay switching, and it may cause the time delay. The same situation will happen after the bus voltage recovery.

2.The minutes and seconds cannot be set to 0 at the same time, if not meet the condition, they can not be configured in ETS, and display red box warning, as shown as follow:

Duration of switch on(contact close)	<input type="text" value="0"/>	min
--[0..240]		
--[0..59]	<input type="text" value="0"/>	s

--Parameter “Duration of switch off: --[0...240]min/[0...59]s”

This parameter defines the duration of switch off when flashing. Options:

0...240 minutes

0...59 seconds

Note: 1.It will not be executed unless the time is lower than the relay threshold switch frequency. Since there will be not sufficient energy to do it because of the frequent relay switching, and it may cause the time delay. The same situation will happen after the bus voltage recovery.

2.The minutes and seconds cannot be set to 0 at the same time, if not meet the condition, they can not be configured in ETS, and display red box warning, as shown as follow:

Duration of switch off(contact open)	<input type="text" value="0"/>	min
--[0..240]		
--[0..59]	<input type="text" value="0"/>	s

Parameter “Number of ON-impulsed (1...255, 0=no limited)”

This parameter sets the flashing times. 0 means no limited. A flashing includes an on and an off. Options: **0...255**

Parameter “Output status after flashing”

This parameter defines the relay contact position after flashing. Options:

Unchange

Contact open

Contact close

Parameter "Control mode of flashing"

This parameter is used to select the control mode of the flashing output. Options:

Start with "1" , Stop with "0"

Start with "0" , Stop with "1"

Start with "0/1" , can not be stop

"Start with '1', Stop with '0'": It will stop flashing with "0". The stop position is defined via last parameter.

"Start with '0', Stop with '1'": It will stop flashing with "1". The stop position is defined via last parameter.

"Start with '0/1', can not be stop": Under this circumstance it cannot terminate the flashing by value until operation over, unless it is blocked by other operation or wait for execution finish.

4.3.2.1.3 "Staircase"

The parameter window "Type of time function-Staircase" setting interface in Fig. 4.3.2.1.3 will be visible when selecting "Staircase" in the parameter "Type of time function".

Type of time function	Staircase
Duration of staircase lighting --[0..1000]	1 min
--[0..59]	0 s
Control mode of staircase lighting	Start with "1",Stop with"0"
During the lighting time,if receive the "start" telegram	Restart duration of staircase lighting

Fig.4.3.2.1.3 Parameter window"Type of time function - Staircase"

The staircase lighting can be started via the object "Staircase function". The value that switches on the staircase lighting can be set via a parameter. The duration time of the lighting on is also set via a parameter.

Parameter "Duration of staircase lighting:--[0...1000]min/[0...59]s"

This parameter describes the duration time when switching on the staircase light function. Options:

0...1000 Minutes

0...59 Seconds

Note: The minutes and seconds cannot be set to 0 at the same time, if not meet the condition,

they can not be configured in ETS, and display red box warning, as shown as follow:

Duration of staircase lighting --[0..1000]	<input type="text" value="0"/>	min
--[0..59]	<input type="text" value="0"/>	s

Parameter "Control mode of staircase lighting"

This parameter is used to select the control mode of the staircase lighting output. Choose suitable control mode according to the needs. Options:

Start with "1", Stop with "0"

Start with "1", no reaction with "0"

Start with "0/1", can not be stop

Start with "1", OFF with "0"

"Start with '1', Stop with '0'": It will switch on the staircase lights with the value "1"; it will stop the time counting operation with "0" and don't change the contact position until changed by other operations.

"Start with '1', no reaction with '0'": It will switch on the staircase lights with the value "1" and no reaction with "0".

"Start with '0/1', can not be stop": It will switch on the staircase lights either with "0" or "1" but cannot stop it until the duration time finished or changed by other operation.

"Start with '1', OFF with '0'": It will switch on the staircase lights with the value "1", and off with "0".

Parameter "During the lighting time ,if receive the 'start' telegram"

Options:

Restart duration of staircase lighting

Extend duration time

Ignore the "start" telegram

"Restart duration of staircase lighting": If the object "Staircase function" again receive the telegram of starting staircase lighting during the duration time, then the staircase lighting will restart and the duration time will be restart.

"Extend duration time": If the object "Staircase function" again receive the telegram of starting staircase lighting during the duration time, then the duration of the staircase lighting will be extended based on the current timing. For example, the duration of the staircase light is set to 60 seconds, and the current time is 20 seconds, then after receiving a start telegram, the lighting time of the staircase light will become 40+60=100seconds, and the staircase lighting will automatically turn off after 100 seconds. If multiple start telegrams are received continuously, the duration time will continue to accumulate before the maximum time limit is reached.

"Ignore the 'start' telegram": It will ignore the receiving start telegram of the object "Staircase

function” during the duration time.

4.3.2.2 Parameter window“Logic”

The parameter window “Logic” setting interface shown in Fig. 4.3.2.2, it will shown up in Fig. 4.3.2(2) “Output X: Function” when selecting “enable” in “Function of “Logic”.

Enable input 0	<input checked="" type="checkbox"/>
Input 0 reverse	<input checked="" type="radio"/> No <input type="radio"/> Yes
<hr/>	
The input 1 of logic	<input checked="" type="checkbox"/>
Logic function type	XOR
Input 1 reverse	<input checked="" type="radio"/> No <input type="radio"/> Yes
Invert result(if no,1=contact close,0=contact open;while yes is opposite)	<input checked="" type="radio"/> No <input type="radio"/> Yes
Value of input1 after bus recovery	0
<hr/>	
The input 2 of logic	<input checked="" type="checkbox"/>
Logic function type	AND
Input 2 reverse	<input checked="" type="radio"/> No <input type="radio"/> Yes
Invert result(if no,1=contact close,0=contact open;while yes is opposite)	<input checked="" type="radio"/> No <input type="radio"/> Yes
Value of input2 after bus recovery	0

Fig.4.3.2.2 Parameter window“ Logic”

There are 2 logic communication objects to decide the status of each output, which are related to the "Switch".

It will re-operate when receiving a new object value as the final output status (close the contact with “1”, open it with “0”). The values of the communication object “Logic 1” makes logic operation with “switch” firstly, and then the result after that will makes operations with the value of “Logic 2”. This operation will ignore the objects which are unable, and continue to the next step with the ones who are

enabled.

Parameter "Enable input 0"

This parameter is used to enable the function of logic operation of "Input 0", whose value are wrote by the object "Switch".

In the both cases of "Input 0" enabled and not enabled, there are a little different parameters. All parameters of logic function have described in the following. If input x is disabled, the setting parameters will be less. If there are not certain parameters in the case, then it is also not available with the function of these parameters.

--Parameter "Input 0/1/2 reverse"

This parameter defines whether reverse the value of Input 0/1/2. Reverse it with "Yes", don't with "No". Options:

No

Yes

Parameter "The input x of logic (x = 1, 2)"

This parameter is used to enable Input 1 and Input 2. If enable, their communication objects "Logic 1" and "Logic 2" will be also visible.

Parameter "Logic function type"

This parameter set logic function type, provided three standard logic operations: AND, OR, XOR, and a GATE function. Explanation of gate function: it will use the next logic value as the enable mark of the previous logic. If the enable mark of the next logic is "1", that means it is able to use the previous logic value as the operation result. E.g. the value of input 1 is 1, that means the value of input 0 can be used as the operation result; if the value 2 is 1, that means the operation value of input 1 or input 0/1 can be used as the result. Options:

AND

OR

XOR

GATE

Below result of logic operation is possible:

Logic function	Object values					Description
	Input0(Switch)	Input1	Result of Input 0/1	Input2	Output	
AND	0	0	0	0	0	The result is 1 if both input values are 1.
	0	1	0	1	0	
	1	0	0	0	0	

Homira

KNX 3-fold 0-10V Mini Dimmer

	1	1	1	1	1	
OR	0	0	0	0	0	The result is 1 if one of both input values is 1
	0	1	1	1	1	
	1	0	1	0	1	
	1	1	1	1	1	
XOR	0	0	0	0	0	The result is 1 if both input values have a different value.
	0	1	1	1	0	
	1	0	1	0	1	
	1	1	0	1	1	
GATE	0	Closed		Closed		The input 0 of value is only allowed through if the GATE (input 1 and input 2) is open. Otherwise the input0 of value is ignored.
	0	Open	0	Open	0	
	1	Closed		Closed		
	1	Open	1	Open	1	

Note:

1. The value of the communication object "Input 1" makes logic operation with "Switch" firstly, and then the result will makes operations with the value of "Input 2", and the final operation result as the final output (close the contact with "1", open it with "0").
2. If an input is not enabled, the input is ignored.
3. If logical result needs to be reverse, the first reverse, then the next step.
- 4, The signal can be passed if the GATE is open, otherwise it is ignored. For example, the input 0 of value is ignored when the GATE of input 1 is closed, and the output is directly determined by the input 2.

Parameter "Invert result(if no,1=contact close,0=contact open;while yes is opposite)"

This parameter defines whether negate the logical operation results. Negate it with "yes", don't with "no". Options:

No

Yes

Parameter "Value of input 1/2 after bus recovery"

This parameter defines the default value of the object "Logic 1/2"after bus voltage recovery.

Options:

0

1

Value before power off

4.3.2.3 Parameter window“Scene”

The parameter window “Scene” setting interface shown in Fig. 4.3.2.3 will be visible when selecting “enable” in “Function of ‘Scene’” in Fig. 4.3.2(2), here can set 8 scenes.

Overwrite scene stored values during download	<input checked="" type="checkbox"/>
1 > channel is assigned to [1..64,0=no assignment]	0
Output status is	<input checked="" type="radio"/> Contact open <input type="radio"/> Contact close
<hr/>	
2 > channel is assigned to [1..64,0=no assignment]	0
Output status is	<input checked="" type="radio"/> Contact open <input type="radio"/> Contact close
<hr/>	
3 > channel is assigned to [1..64,0=no assignment]	0
Output status is	<input checked="" type="radio"/> Contact open <input type="radio"/> Contact close
<hr/>	
4 > channel is assigned to [1..64,0=no assignment]	0
Output status is	<input checked="" type="radio"/> Contact open <input type="radio"/> Contact close

Fig.4.3.2.3 Parameter window“Scene”

Parameter “Overwrite scene stored values during download”

This parameter sets whether to overwrite the scene save value during application download.

Options:

When this parameter is disable: If selecting “Disable”, the stored values before the download can be not overwritten by the parameterized scene value. When the scene is called, the scene saved before the download is still enabled until it is replaced by the new storage scene.

When this parameter is enable: If selecting “Enable”, the stored values will be overwritten by the parameterized scene value during the download. When the scene is called, the scene will be set according to the parameters until it is replaced by the new storage scene.

Parameter “X > channel is assigned to [1...64 ,0= no assignment],(X=1-8)”

It is able to allocate 64 different scene numbers to every output. There are 8 various scenes can be set per output. Options: **Scene 1... Scene 64** , **0=no assignment**

--Parameter “Output status is”

This parameter defines the switch output status when recall the scene. Options:

Contact open

Contact close

4.3.2.4 Parameter window "Forced"

The parameter window "Forced" setting interface in Fig. 4.3.2.4 "Output X: Function" will be visible with "Enable" in the parameter "Function of "Forced"" in Fig. 4.3.2(2).

Function of "Time"	<input type="checkbox"/>
Function of "Logic"	<input type="checkbox"/>
Function of "Scene"	<input type="checkbox"/>
Function of "Forced"	<input checked="" type="checkbox"/>
Force operation type	<input checked="" type="radio"/> 1Bit <input type="radio"/> 2Bit
Output status if forced operation	Contact open ▼
Function of "Operation hours counter"	<input type="checkbox"/>

Fig.4.3.2.4 Parameter window "Forced"

This function will be used in some special situation such as emergency, and are activated by the object "Forced output" with the highest priority in the system, which means only forced operation are valid in this case.

Parameter "Force operation type"

This parameter defines the control type of force operation. Options:

1bit

2bit

1bit: The object "Forced output" receives the telegram "1" to activate force operation, telegram "0" to cancel the force operation.

2bit: When the object "Forced output" receives a telegram value, the action as follow:

Value of the object "Forced output, X"	Action
00b (0) , 01b (1)	Cancel force operation, other operation can be performed
10b (2)	Force switch off (OFF)

11b (3)

Force switch on (ON)

When cancel the forced operation, the position of relay contact is unchanged. However, if time function(Delay/Flashing/Staircase) is running before forced operation, then time order will still continue during forced operation, if cancel the forced operation, time counting has not finished, it will continuously operate time function.

Parameter "Output status if forced operation"

This parameter is visible if the option "1 bit" is selected via last parameter, which defines the contact position of force operation. Options:

Unchange

Contact open

Contact close

Unchange: The position of contact will keep on the current status.

Contact open: The position of contact is opened.

Contact close: The position of contact is closed.

The priority for various operations of switch actuator control:

Initialization(After the parameter download is completed)→force operation→general operation.

Forced operations have the highest priority, and all other operations are ignored during forced operations. Controlling telegrams received during forced operation is ignored.

4.3.2.5 Parameter window"Operation hours counter"

The parameter window "Operation hours counter" setting interface in Fig. 4.3.2.5 will be visible with "enable" in the parameter "Function of "Operation hours counter"" in Fig. 4.3.2(2). The function is use for counting the time of relay on.

Function of "Time"	<input type="checkbox"/>
Function of "Logic"	<input type="checkbox"/>
Function of "Scene"	<input type="checkbox"/>
Function of "Forced"	<input type="checkbox"/>
Function of "Operation hours counter"	<input checked="" type="checkbox"/>
Object datatype of "Operation hours counter"	<input type="radio"/> 2 byte Value in h(DPT7.007) <input checked="" type="radio"/> 4 byte Value in s(DPT13.100)
Cyclically send counter value in [0..100] ("0" = not send,only for reading)	<input type="text" value="0"/> h

Fig.4.3.2.5 Parameter window "Operation hours counter"

Parameter "Object datatype of " Operation hours counter"

This parameter is used to select data type of the operation hours counter. Options:

2 byte Value in h(DPT7.007)

4 byte Value in s(DPT13.100)

The "2 byte Value in h (DPT 7.007)" option indicates that the count value is 2 bytes; the "4 byte Value in s (DPT 13.100)" option indicates that the count value is 4 bytes.

Parameter "Cyclically send counter value in [0..100] (0=not send, only for reading)"

The parameter determines the time interval to send the telegram which is used for counting the time of relay on. Available options: **0-100**

"0" means do not send. "1-100" means 1 hours to 100 hours cyclically send the value. When the parameter "Object of switch and operation hours counter" is set to 2 bytes, the operation time is in hours; when it is 4 bytes, the operation time is in s.

4.3.3 Parameter window "Dimming CCT"

Description (max 30char.)	<input type="text"/>
General dimming time (from min. to max.)	<input type="text" value="4"/> s
Minimum brightness value	<input type="text" value="1"/> %
Maximum brightness value	<input type="text" value="100"/> %
Minimum physical colour temperature (refer to the technical spec. of warm white)	<input type="text" value="2700"/> K
Maximum physical colour temperature (refer to the technical spec. of cool white)	<input type="text" value="6500"/> K
Minimum colour temperature control	<input type="text" value="2700"/> K
Maximum colour temperature control	<input type="text" value="6500"/> K
Brightness value for switching on	<input checked="" type="radio"/> Preset brightness value <input type="radio"/> Last brightness value
Preset brightness value	<input type="text" value="100"/> %
Colour temperature value for switching on	<input checked="" type="radio"/> Preset colour temperature value <input type="radio"/> The current value
Preset colour temperature value	<input type="text" value="4500"/> K
Behavior when receiving relative colour temperature telegram when the light off	<input type="text" value="Ignore the telegram"/>
Behavior when receiving absolute colour temperature telegram when the light off	<input type="text" value="Only update the current colour temperature value"/>
Dimming mode selection for switching on	<input type="radio"/> Jumping <input checked="" type="radio"/> Dimming
Dimming mode selection for switching off	<input checked="" type="radio"/> Jumping <input type="radio"/> Dimming
Dimming mode selection for absolute colour temperature	<input checked="" type="radio"/> Jumping <input type="radio"/> Dimming
Dimming time for relative colour temperature	<input type="text" value="4"/> s
Dimming time for relative dimming	<input type="text" value="4"/> s
Dimming time for absolute dimming	<input type="text" value="4"/> s
Allow switch off via relative dimming	<input checked="" type="checkbox"/>

Absolute dimming value lower than the minimum value 0%=0%, otherwise=Minimum brightness value ▾

Reset behavior

Behavior after download Switching off Preset brightness value

Preset brightness value 100 ▾ %

Preset colour temperature value 4500 ▾ K

Behavior after bus failure Switching off Unchange

Behavior after bus recovery Preset brightness value ▾

Preset brightness value 100 ▾ %

Preset colour temperature value 4500 ▾ K

Status feedback

Switching Respond after read only
 Respond after change

Brightness value Respond after read only
 Respond after change

Colour Temperature value Respond after read only
 Respond after change

Extension function

Scene function

Forced function

Number of sequence function 1 ▾

Fig.4.3.3 Parameter window“Dimming CCT”

Parameter “Description (max 30char.)”

This parameter is for setting the name description of the channel, up to input 30 characters.

Parameter “General dimming time (from min. to max.)”

This parameter is for setting the time for the whole dimming process, which refers to the time from minimum to maximum value. Suppose the time is set as 6s, the min. Value is 0% and the max. is 100%, if the brightness is only dimmed from 0% to 50%, then the dimming time only takes 3s.

Options: **2...255 s**

If the channel function has not specified a dimming time, use the time set by this parameter, functions such as switch on/off lamps, forced etc.

Parameter "Minimum brightness value"

Parameter "Maximum brightness value"

These parameters are for setting minimum and maximum brightness values individually, to limit the output range of dimming brightness, which is allow the lamps work in a better brightness range depending on the environment or lamps compatibility.

This range is not allowed to be exceeded in any status of lamps on, such as forced functions, etc. Output as min. value when the brightness is lower than the min., and output as max. value when it is higher than the max.

Options of the min. value: **1...49 %**; Options of the max. value: **50...100 %**

Parameter "Minimum physical colour temperature(refer to the technical spec. of warm white)"

Parameter "Maximum physical colour temperature(refer to the technical spec. of cool white)"

These parameters are for setting minimum and maximum physical colour temperature, which is derived from the technical parameters of the lamps. Options: **2000...7000K**

Lamps output colour temperature: Minimum Physical Colour Temperature ≤ Minimum Colour Temperature ≤ light output colour temperature ≤ Maximum Colour Temperature ≤ Maximum Physical Colour Temperature. Otherwise it can not be set on the ETS:

Minimum physical colour temperature (refer to the technical spec. of warm white)	<input type="text" value="3100"/>	K
Maximum physical colour temperature (refer to the technical spec. of cool white)	<input type="text" value="2000"/>	K
Minimum colour temperature control	<input type="text" value="3000"/>	K
Maximum colour temperature control	<input type="text" value="2000"/>	K

Parameter "Minimum colour temperature control"

Parameter "Maximum colour temperature control"

These parameters are for setting minimum and maximum colour temperature values individually, to limit the output range of colour temperature. Options: **2000...7000K**

This range is not allowed to be exceeded in any status of lamps on, such as forced etc. Output as min. value when the brightness is lower than the min., and output as max. value when it is higher than the max.

Note: Needs to be configured within the range of physical colour temperatures.

Parameter "Brightness value for switching on"

This parameter is for setting the brightness when the lamp is switched on. Options:

Preset brightness value

Last brightness value

Note: Outputs 50% when the brightness value is uncertain.

--Parameter "Preset brightness value"

This parameter is visible when previous parameter is selected "Preset brightness value". Set the preset brightness value. Options: **1...100 %**

Parameter "Colour temperature value for switching on"

This parameter is for setting the colour temperature when the lamp is switched on. Options:

Preset colour temperature value

The current value

The current value: Related to the configuration of the parameter "Behavior when receiving relative/absolute color temperature telegram at the light off", if there is an update to the colour temperature value during the lamp off period, the latest color temperature value is followed, if it is ignored, the current value is the value of the last lamp on.

Note: Outputs 4500K when the colour temperature value is uncertain.

--Parameter "Preset colour temperature value"

This parameter is visible when previous parameter is selected "Preset colour temperature value". Set the preset colour temperature value. Options: **2000...7000K**

Parameter "Behavior when receiving relative colour temperature telegram at the light off"

This parameter is for setting the behavior when receiving relative colour temperature telegram at the light off. Options:

Ignore the telegram

Only update the current colour temperature value

Update the current colour temperature value and switch the light on

Ignore the telegram: Ignore when receiving relative colour temperature telegram at the light off.

Only update the current colour temperature value: Only update the current colour temperature value when receiving relative colour temperature telegram at the light off.

Update the current colour temperature value and switch the light on: Update the current colour temperature value and switch the light on when receiving relative colour temperature telegram at the light off.

Parameter "Behavior when receiving absolute colour temperature telegram at the light off"

This parameter is for setting the behavior when receiving absolute colour temperature telegram at the light off. Options:

Ignore the telegram

Only update the current colour temperature value

Update the current colour temperature value and switch the light on

Ignore the telegram: Ignore when receiving absolute colour temperature telegram at the light off.

Only update the current colour temperature value: Only update the current colour temperature value when receiving absolute colour temperature telegram at the light off.

Update the current colour temperature value and switch the light on: Update the current colour temperature value and switch the light on when receiving absolute colour temperature telegram at the light off.

Parameter "Dimming mode selection for switching on"

This parameter is for setting the dimming mode when the lamp is switched on. Options:

Jumping

Dimming

Jumping: Switch on immediately and directly to the target brightness.

Dimming: Switch on with dimming to the target brightness and use the General dimming time.

Parameter "Dimming mode selection for switching off"

This parameter is for setting the dimming mode when the lamp is switched off. Options:

Jumping

Dimming

Jumping: Switch off immediately.

Dimming: Switch off with dimming and use the General dimming time.

Parameter "Dimming mode selection for absolute colour temperature"

This parameter is for setting the dimming mode selection for absolute colour temperature. Options:

Jumping

Dimming

Jumping: Adjust to the target color temperature immediately.

Dimming: Adjust to the target color temperature, the dimming time is set by the next parameter.

--Parameter "Dimming time for absolute colour temperature"

This parameter is for setting the time for the whole absolute colour temperature process. Options:

2...255 s

Parameter "Dimming time for relative colour temperature"

This parameter is for setting the time for the whole relative colour temperature process. Options: **2...255 s**

Parameter "Dimming time for relative dimming"

This parameter is for setting the time for the whole relative dimming process. Options: **2...255 s**

Parameter "Dimming time for absolute dimming"

This parameter is for setting the time for the whole absolute dimming process. Options: **2...255 s**

Parameter "Allow switch off via relative dimming"

This parameter is for setting whether allow to switch lamp off via relative dimming. When disabled, it can only be adjusted downward to the minimum brightness value; while enabled, switch the lamp off directly when the brightness is dimming to less than the minimum brightness value.

Parameter "Absolute dimming value lower than the minimum value"

This parameter is for setting the behaviour when absolute dimming value less than the minimum value, **it only affects the object "Absolute dimming"**. Options:

0%=0%, otherwise=Minimum brightness value

To be the minimum brightness value

To be 0%

0%=0%, otherwise=Minimum brightness value%: Output as min. value when the value is less than the min., but the value is 0% is to switch the lamp off.

To be the minimum brightness value: Output as min. value when the value is less than the min., even if the value is 0%.

To be 0%: Switch the lamp off directly when the value is less than the min.

Reset behavior

Parameter "Behavior after download"

This parameter is for setting the behaviour of channel after download. Options:

Switching off

Preset brightness value

Preset brightness value: Dimming to a setting brightness, defined by next parameter.

--Parameter "**Preset brightness value**"

This parameter is visible when "Preset brightness value" is selected. Set the preset brightness value. Options: **1...100 %**

--Parameter "Preset colour temperature value"

This parameter is for setting the preset colour temperature value. Options: **2000...7000K**

Parameter "Behavior after bus failure"

This parameter is for setting the behaviour of channel after bus failure. Options:

Switching off

Unchange

Parameter "Behavior after bus recovery"

This parameter is for setting the behaviour of channel after bus recovery. Options:

Switching off

Preset brightness value

Brightness before bus failure

Preset brightness value: Dimming to a setting brightness, defined by next parameter.

Brightness before bus failure: Recover to the brightness value stored when the bus failure.

--Parameter "Preset brightness value"

This parameter is visible when "Preset brightness value" is selected. Set the preset brightness value. Options: **1...100 %**

--Parameter "Preset Colour temperature value"

This parameter is visible when "Value before bus failure" is not selected. Set the preset colour temperature value. Options: **2000...7000K**

Status feedback

Parameter "Switching/Brightness value/Colour Temperature value"

These parameters are for setting the way to feed back the status of switch, brightness, colour temperature status.

Options:

Respond after read only

Respond after change

Extension function

Parameter "Scene function"

Setting page of scene function interface is visible after this parameter enabled. For detailed operations, refer to section 4.3.3.1.

Parameter "Forced function"

Setting page of forced function interface is visible after this parameter enabled. For detailed operations, refer to section 4.3.3.2.

Parameter “Number of sequence function”

This parameter is for setting the number of sequences to be enabled, and the corresponding parameter interface is visible after enabling. Options: **None/1/2/3/4**

For detailed operations, refer to section 4.3.3.3.

4.3.3.1 Parameter window “Scene function”

Overwrite scene stored values during download

Scenes	Description	Scene NO.	Brightness control	Brightness value	Colour control	Colour temp.	Dimming
Scene 1		1	<input checked="" type="checkbox"/>	50 %	<input checked="" type="checkbox"/>	4500 K	4 s
Scene 2		0	NA	NA	NA	NA	NA
Scene 3		0	NA	NA	NA	NA	NA
Scene 4		0	NA	NA	NA	NA	NA
Scene 5		0	NA	NA	NA	NA	NA
Scene 6		0	NA	NA	NA	NA	NA
Scene 7		0	NA	NA	NA	NA	NA
Scene 8		0	NA	NA	NA	NA	NA
Scene 9		0	NA	NA	NA	NA	NA
Scene 10		0	NA	NA	NA	NA	NA
Scene 11		0	NA	NA	NA	NA	NA
Scene 12		0	NA	NA	NA	NA	NA
Scene 13		0	NA	NA	NA	NA	NA
Scene 14		0	NA	NA	NA	NA	NA
Scene 15		0	NA	NA	NA	NA	NA
Scene 16		0	NA	NA	NA	NA	NA

Fig.4.3.3.1 Parameter window “Scene function”

Scene function can work with the control panel or other software to execute the setting scene and output the specified brightness.

Parameter “Overwrite scene stored values during download”

This parameter is for setting whether to overwrite the scene stored values during application download. If select to overwrite, follow the parameter setting, otherwise for the brightness value corresponding to the scene number that has saved the modified value has executed, the last saved

value will remain; for the modified brightness has not executed, still use the value set by parameter.

Scene x (x=1~16)

Parameter "Description"

This parameter is for setting the name description of the corresponding scene, up to 30 characters.

Parameter "Scene NO."

This parameter is for setting the triggered scene number, up to 16 scenes. Options: **0...64**

When scene number is 0, it is invalid, and the brightness control, brightness value, colour control, colour temp. and dimming time cannot be set, as shown as following:

Scenes	Description	Scene NO.	Brightness control	Brightness value	Colour control	Colour temp.	Dimming
Scene 1		0	NA	NA	NA	NA	NA

When scene numbers are greater than 0, if there are same scene numbers, display following error message:

 Exist multiple scene NO. assignment conflict, the valid scene NO. can't be the same, please correct, otherwise only the first one of those conflict scene is valid and others will be ignored

Parameter "Brightness control"

This parameter sets whether to enable scene brightness control.

Parameter "Brightness value"

This parameter is for setting the brightness of the corresponding scene. Options: **0...100 %**

Parameter "Colour control"

This parameter sets whether to enable scene colour control.

Parameter "Colour temp."

This parameter is for setting the colour temperature of the corresponding scene. Options: **2000...7000K**

Parameter "Dimming"

This parameter is for setting the dimming time of the corresponding scene. Options: **2...255 s**

4.3.3.2 Parameter window "Forced function"

Forced operation datatype	<input checked="" type="radio"/> 1bit <input type="radio"/> 2bit
Forced operation at object value	<input type="radio"/> 0=Forced/1=Cancel <input checked="" type="radio"/> 1=Forced/0=Cancel
Behavior at forced operation	Preset brightness and colour temperature value ▾
Preset brightness value	100 ▾ %
Preset colour temperature value	4500 ▾ K
Behavior at end of forced operation	Preset brightness and colour temperature value ▾
Preset brightness value	20 ▾ %
Preset colour temperature value	4500 ▾ K
1bit	
Forced operation datatype	<input type="radio"/> 1bit <input checked="" type="radio"/> 2bit
Behavior at forced operation "switch on"	Preset brightness and colour temperature value ▾
Preset brightness value	100 ▾ %
Preset colour temperature value	4500 ▾ K
Behavior at forced operation "switch off"	Switching off
Behavior at end of forced operation	Preset brightness and colour temperature value ▾
Preset brightness value	20 ▾ %
Preset colour temperature value	4500 ▾ K
2bit	

Fig.4.3.3.2 Parameter window "Forced function"

The forced function can force the lamp at a preset brightness and colour temperature in some special situations. Forced function has the highest priority. Ignore the normal control telegram received from bus when during in forced operation.

Parameter "Forced operation datatype"

This parameter is for setting the datatype of forced operation. Options:

1bit

2bit

Parameter "Forced operation at object value"

This parameter is visible when 1bit. Set the object value for activating or canceling the forced. Options:

0=Forced/1=Cancel

1=Forced/0=Cancel

Parameter "Behavior at forced operation"

This parameter is visible when 1bit. Set behavior at forced operation. Options:

Switching off

Only preset brightness value

Only preset colour temperature value

Preset brightness and colour temperature value

Unchange

--Parameter "Preset brightness value"

This parameter is visible when "Only preset brightness value/Preset brightness and colour temperature value" is selected. Set the preset brightness value. Options: **1...100 %**

--Parameter "Preset colour temperature value"

This parameter is visible when "Only preset brightness value/Preset brightness and colour temperature value" is selected. Set the preset colour temperature value. Options: **2000...7000K**

Parameter "Behavior at forced operation "switch on" "

This parameter is visible when 2bit. Set the behavior at forced operation "switch on" when receive telegram "3". Options:

Only preset brightness value

Only preset colour temperature value

Preset brightness and colour temperature value

Unchange

--Parameter "Preset brightness value"

This parameter is visible when "Only preset brightness value/Preset brightness and colour temperature value" is selected. Set the preset brightness value. Options: **1...100 %**

--Parameter "Preset colour temperature value"

This parameter is visible when "Only preset brightness value/Preset brightness and colour temperature value" is selected. Set the preset colour temperature value. Options: **2000...7000K**

Parameter "Behavior at forced operation "switch off" "

This parameter is visible when 2bit. Set the behavior at forced operation "switch off" when receive telegram "2". Option is only **Switching off**

Parameter "Behavior at end of forced operation"

This parameter is for setting the behavior at end of forced operation.

Note: the telegram values 0/1 from 2bit are used to cancel forced operation.

Options:

Switching off

Only preset brightness value

Only preset colour temperature value

Preset brightness and colour temperature value

Unchange

When receive a telegram to end forced operation, it is valid if the forced operation has been activated before, otherwise ignore the telegram.

--Parameter "Preset brightness value"

This parameter is visible when "Only preset brightness value/Preset brightness and colour temperature value" is selected. Set the preset brightness value. Options: **1...100 %**

--Parameter "Preset colour temperature value"

This parameter is visible when "Only preset brightness value/Preset brightness and colour temperature value" is selected. Set the preset colour temperature value. Options: **2000...7000K**

4.3.3.3 Parameter window "Sequence X (X=1~4)"

Description (max 30char.)	<input type="text"/>
Work mode	Breathing ▼
Assign Scene NO. to start sequence [1..64,0=no assignment]	0 ▲▼
Number of sequence execution (0=no limit)	1 ▲▼
Behavior after the end	Switching off ▼
Additional behavior when receiving a sequence "stop" telegram	<input checked="" type="radio"/> Switching off <input type="radio"/> Unchange
Behavior when receiving a switch on/ relative dimming/absolute dimming telegram	<input type="radio"/> Ignore, and keep running <input checked="" type="radio"/> Stop running
Behavior when receiving a switch "OFF" telegram	<input checked="" type="radio"/> Switching off and stop sequence <input type="radio"/> Ignore, and keep running
Behavior when receiving a relative/ absolute colour temperature telegram	Stop running ▼
<hr/>	
Number of step	7 ▼
Step 1	
Brightness value	100 ▲▼ %
Colour Temperature value	4500 ▲▼ K
Pause time	0 ▲▼ s
Breathing time of the next step	4 ▲▼ s
Step 2	
Brightness value	100 ▲▼ %
Colour Temperature value	4500 ▲▼ K
Pause time	0 ▲▼ s
Breathing time of the next step	4 ▲▼ s

Fig.4.3.3.3 Parameter window "Sequence X-{{0:...}},(X=1~4)"

Parameter "Description (max 30char.)"

This parameter is for setting the name description of the sequence, up to input 30 characters.

Parameter "Work mode"

This parameter is for setting the lamps work mode for the sequence. Options:

Breathing

Jumping

Dimming

Parameter "Assign Scene NO. to start sequence [1..64,0=no assignment] "

This parameter is for setting the assign scene number to start sequence. Options: **0..64**

Note: When 2 or more sequences are configured to conflict, the first conflicting scene is executed and the others scenes are ignored.

Parameter "Number of sequence execution (0=no limit)"

This parameter is for setting the number of sequence execution. Options: **0...255**

0: Unlimited cyclic sequences, unless interrupted by sequence start/stop objects or other control commands.

1: An acyclic sequence that is executed only once.

2..255: Loop sequence, after the last parameter step, the sequence will restart until the loop count is reached, ending the sequence.

Parameter "Behavior after the end"

In the case of a sequence with limited loop, sets the behavior after the end. Options:

Switching off

Start Sequence 1/2/3/4

Unchange

Sequence 1/2/3/4: When "Number of sequence executions" is greater than 1, it is visible. After the current sequence finishes running, continue with running another sequence, x.

Parameter "Additional behavior when receiving a sequence "stop" telegram"

This parameter is for setting the behavior when receiving a sequence "stop" telegram. Options:

Switching off

Unchange

Parameter "Behavior when receiving a switch on/relative dimming/absolute dimming telegram"

This parameter is for setting the sequence behavior when receiving a "switch on/relative dimming/absolute dimming" telegram.

When the lamps work mode is breathing, Options: **Ignore, and keep running/Stop running**

When the lamps work mode is "jumping" or "dimming", Options:

Execute and update step preset value, and keep running

Execute and not update step preset value, and keep running

Ignore, and keep running

Stop running

Note: 1. The sequence stop running when it receives a command for an extension function, such as scene, forced.

2. When a "0" command is received, the sequence will only be executed and not saved.

Parameter "Behavior when receiving a switch "OFF" telegram"

This parameter is for setting the sequence behavior when receiving a switch "OFF" telegram. Options:

Switching off and stop sequence

Ignore, and keep running

Switching off and stop sequence: Switching off the lamp and stop sequence when receiving a switch "OFF" telegram.

Ignore, and keep running: Ignore and keep running sequence when receiving a switch "OFF" telegram.

Parameter "Number of step"

This parameter is for setting the number of steps for the sequence to run, up to 7. Options: 1...7

Note: There is no option "1" when "Dimming" and "Jumping" are selected for the lamp work mode.

Parameter "Brightness value"

This parameter is for setting the lamp brightness value. Options: 1...100%

Parameter "Colour Temperature value"

This parameter is for setting the lamp colour temperature value. Options: 2000...7000K

Parameter "Pause time"

When "Breathing" is selected for work mode, this parameter sets the pause time after the lamp of the current step is adjusted to the minimum brightness, and then adjust the brightness again to the target brightness value of the next step (this time is counted after the breathing period).

When "Jump" is selected for work mode, this parameter sets the pause time after switching to the target brightness value, and then immediately switch to the target brightness value of the next step.

When "Dimming" is selected for work mode, this parameter sets the pause time after reaching

the target brightness value before starting to fade to the next target brightness value.

Options: **0...14400s**

Parameter "Breathing time of the next step"

This parameter is visible when "Breathing" is selected. Set breathing time of the next step. This refers to the time of gradual change from the lowest brightness to the target value, and then from the target value to the lowest brightness. Options: **2.... .255s**

Note: step1 is regulated at the start-up run of the sequence using the general dimming time until the next step which uses the breathing time set by this parameter, or if during the cycling of the sequence, the breathing time of step1 is determined by the definition of the parameter in the previous step (the last step of this or any other sequence).

Parameter "Transition time to the next step"

This parameter is visible when "Dimming" is selected. Set the dimming time from the current step's target brightness value to the next step's target brightness value (this time is counted after the pause time).

Note: When the sequence starts, step1 uses the general dimming time to adjust the target brightness value.

4.3.4 Parameter window "Dimming RGB"

Description (max 30char.)

General dimming time (from min. to max.) s

	KNX value	Output value		
		R	G	B
Minimum brightness	1	1 <input type="text"/>	1 <input type="text"/>	1 <input type="text"/>
Maximum brightness	255	255 <input type="text"/>	255 <input type="text"/>	255 <input type="text"/>

RGB control type Combined control Individual control

Switching on value Preset brightness value Last brightness value

Preset colour value 

Dimming mode selection for switching on Jumping Dimming

Dimming mode selection for switching off Jumping Dimming

Dimming time for relative dimming s

Dimming time for absolute dimming s

Reset behavior

Behavior after download Switching off Preset colour value

Preset colour value 

Behavior after bus failure Switching off Unchange

Behavior after bus recovery ▼

Preset colour value 

Status feedback

Switching Respond after read only
 Respond after change

RGB Brightness value Respond after read only
 Respond after change

Extension function

Scene function

Forced function

Number of sequence function

Fig.4.3.4 Parameter window“Dimming RGB”

Parameter “Description (max 30char.)”

This parameter is for setting the name description of the channel, up to input 30 characters.

Parameter “General dimming time (from min. to max.)”

This parameter is for setting the time for the whole dimming process, which refers to the time from minimum to maximum value. Suppose the time is set as 6s, the min. Value is 0% and the max. is 100%, if the brightness is only dimmed from 0% to 50%, then the dimming time only takes 3s.

Options: **2...255 s**

If the channel function has not specified a dimming time, use the time set by this parameter, functions such as switch on/off lamps, forced etc.

Parameter “Minimum KNX brightness value--1”

Parameter “Maximum KNX brightness value--255”

This parameter is for display the min/max value of KNX brightness telegram. The range of KNX values is 1-100%, while the output range of KNX corresponding R/G/B values is set by the following parameters.

The conversion between KNX value and RGB value adopts the relationship of linear mapping. For example, if the KNX value is 1-100%, the R range setting value is 30-90%; when the KNX value is 1%, the R value outputs 30%; when the KNX value is 50%, the R value outputs 60%; when the KNX value is 100%, the R value outputs 90%.

Note: The preset RGB values in the parameter and the RGB values received by the bus are KNX values.

--Parameter “Minimum brightness value-R (0.4%~49.9%)”

--Parameter “Minimum brightness value-G (0.4%~49.9%)”

--Parameter "Minimum brightness value-B (0.4%~49.9%)"

--Parameter "Maximum brightness value-R (50.2%~100%)"

--Parameter "Maximum brightness value-G (50.2%~100%)"

--Parameter "Maximum brightness value-B (50.2%~100%)"

These parameters are for setting minimum and maximum RGB values individually, to limit the output range of RGB. This range is not allowed to be exceeded in any status of lamps on, including threshold, forced, safety functions, etc. Output as min. value when the brightness is lower than the min., and output as max. value when it is higher than the max.

Options of the min. value: **1...127**

Options of the max. value: **128...255**

Parameter "RGB control type"

This parameter is for setting the RGB control type. Options:

Combined control

Individual control

Parameter "Switching on value"

This parameter is for setting the colour value when the lamp is switched on. Options:

Preset colour value

Last colour value

--Parameter "Preset colour value"

This parameter is visible when previous parameter is selected "Preset colour value". Set the preset colour value. Options: **#000000 ...#FFFFFF**

Parameter "Dimming mode selection for switching on"

This parameter is for setting the dimming mode when the lamp is switched on. Options:

Jumping

Dimming

Jumping: Switch on immediately and directly to the target brightness.

Dimming: Switch on with dimming to the target brightness and use the General dimming time.

Parameter "Dimming mode selection for switching off"

This parameter is for setting the dimming mode when the lamp is switched off. Options:

Jumping

Dimming

Jumping: Switch off immediately.

Dimming: Switch off with dimming and use the General dimming time.

Parameter "Dimming time for relative dimming"

This parameter is for setting the time for the whole relative dimming process. Options: **2...255 s**

Note: Any RGB adjustment value will use this parameter setting for dimming time.

Parameter "Dimming time for absolute dimming"

This parameter is for setting the time for the whole absolute dimming process. Options: **2...255 s**

Note: Any RGB adjustment value will use this parameter setting for dimming time.

Reset behavior

Parameter "Behavior after download"

This parameter is for setting the behaviour of channel after download. Options:

Switching off

Preset colour value

Preset colour value: Dimming to a setting colour value, defined by next parameter.

--Parameter "Preset colour value"

This parameter is visible when "Preset colour value" is selected. Set the preset colour value.

Options: **#000000#FFFFFF**

Parameter "Behavior after bus failure"

This parameter is for setting the behaviour of channel after bus failure. Options:

Switching off

Unchange

Parameter "Behavior after bus recovery"

This parameter is for setting the behaviour of channel after bus recovery. Options:

Switching off

Preset colour value

Value before bus failure

Preset colour value: Dimming to a setting colour value, defined by next parameter.

Value before bus failure: Recover to the brightness value stored when the bus failure.

--Parameter "Preset Colour value"

This parameter is visible when "Value before bus failure" is not selected. Set the preset colour value. Options: **#000000#FFFFFF**

Status feedback

Parameter "Switching/RGB Brightness value"

These parameters are for setting the way to feed back the status of switch, RGB brightness status.

Options:

Respond after read only

Respond after change

Extension function

Parameter "Scene function"

Setting page of scene function interface is visible after this parameter enabled. For detailed operations, refer to section 4.3.4.1.

Parameter "Forced function"

Setting page of forced function interface is visible after this parameter enabled. For detailed operations, refer to section 4.3.4.2.

Parameter "Number of sequence function"

This parameter is for setting the number of sequences to be enabled, and the corresponding parameter interface is visible after enabling. Options: **None/1/2/3/4**

For detailed operations, refer to section 4.3.4.3.

4.3.4.1 Parameter window“Scene”

Overwrite scene stored values during download

Scenes	Description	Scene NO.	RGB value	Dimming
Scene 1		1	#FFFFFF	4 s
Scene 2		0	NA	NA
Scene 3		0	NA	NA
Scene 4		0	NA	NA
Scene 5		0	NA	NA
Scene 6		0	NA	NA
Scene 7		0	NA	NA
Scene 8		0	NA	NA
Scene 9		0	NA	NA
Scene 10		0	NA	NA
Scene 11		0	NA	NA
Scene 12		0	NA	NA
Scene 13		0	NA	NA
Scene 14		0	NA	NA
Scene 15		0	NA	NA
Scene 16		0	NA	NA

Fig.4.3.4.1 Parameter window“Scene”

Scene function can work with the control panel or other software to execute the setting scene and output the specified brightness.

Parameter “Overwrite scene stored values during download”

This parameter is for setting whether to overwrite the scene stored values during application download. If select to overwrite, follow the parameter setting, otherwise for the brightness value corresponding to the scene number that has saved the modified value has executed, the last saved value will remain; for the modified brightness has not executed, still use the value set by parameter.

Scene X (X=1~16)

Parameter “Description”

This parameter is for setting the name description of the corresponding scene, up to 30 characters.

Parameter "Scene NO."

This parameter is for setting the triggered scene number, up to 16 scenes. Options: **0...64**

When scene number is 0, it is invalid, and the RGB value and dimming time cannot be set, as shown as following:

Scenes	Description	Scene NO.	RGB value	Dimming
Scene 1		0	NA	NA

When scene numbers are greater than 0, if there are same scene numbers, display following error message:

 Exist multiple scene NO. assignment conflict, the valid scene NO. can't be the same, please correct, otherwise only the first one of those conflict scene is valid and others will be ignored

Parameter "RGB value"

This parameter is for setting the RGB value of the corresponding scene.

Options: **#000000 ...#FFFFFF**

Parameter "Dimming"

This parameter is for setting the dimming time of the corresponding scene. Options: **2...255 s**

4.3.4.2 Parameter window "Forced function"





Forced operation datatype	<input checked="" type="radio"/> 1bit <input type="radio"/> 2bit
Forced operation at object value	<input type="radio"/> 0=Forced/1=Cancel <input checked="" type="radio"/> 1=Forced/0=Cancel
Behavior at forced operation	Preset colour value ▾
Preset colour value	#FFFFFF 
Behavior at end of forced operation	Preset colour value ▾
Preset colour value	#FFFFFF 
	1bit
Forced operation datatype	<input type="radio"/> 1bit <input checked="" type="radio"/> 2bit
Behavior at forced operation "switch on"	<input checked="" type="radio"/> Preset colour value <input type="radio"/> Unchange
Preset colour value	#FFFFFF 
Behavior at forced operation "switch off"	Switching off
Behavior at end of forced operation	Preset colour value ▾
Preset colour value	#FFFFFF 
	2bit

Fig.4.3.4.2 Parameter window "Forced function"

The forced function can force the lamp at a preset colour value in some special situations. Forced function has the highest priority. Ignore the normal control telegram received from bus when during in forced operation.

Parameter "Forced operation datatype"

This parameter is for setting the datatype of forced operation. Options:

1bit

2bit

Parameter "Forced operation at object value"

This parameter is visible when 1bit. Set the object value for activating or canceling the forced. Options:

0=Forced/1=Cancel

1=Forced/0=Cancel

Parameter "Behavior at forced operation"

This parameter is visible when 1bit. Set behavior at forced operation. Options:

Switching off

Preset colour value

Unchange

--Parameter "Preset colour temperature value"

This parameter is visible when "Preset colour value" is selected. Set the preset colour temperature value. Options: #000000#FFFFFF

Parameter "Behavior at forced operation "switch on""

This parameter is visible when 2bit. Set the behavior at forced operation "switch on" when receive telegram "3". Options:

Preset colour value

Unchange

--Parameter "Preset colour value"

This parameter is visible when "Preset colour value" is selected. Set the preset colour temperature value. Options: #000000#FFFFFF

Parameter "Behavior at forced operation "switch off""

This parameter is visible when 2bit. Set the behavior at forced operation "switch off" when receive telegram "2". Option is only **Switching off**

Parameter "Behavior at end of forced operation"

This parameter is for setting the behavior at end of forced operation.

Note: the telegram values 0/1 from 2bit are used to cancel forced operation.

Options:

Switching off

Preset colour value

Unchange

When receive a telegram to end forced operation, it is valid if the forced operation has been activated before, otherwise ignore the telegram.

--Parameter "Preset colour value"

This parameter is visible when "Preset colour value" is selected. Set the preset colour value. Options: #000000#FFFFFF

4.3.4.3 Parameter window "Sequence X (X=1~4)"

Description (max 30char.)	<input type="text"/>
Work mode	Breathing ▼
Assign Scene NO. to start sequence [1..64,0=no assignment]	0 ▲▼
Number of sequence execution (0=no limit)	1 ▲▼
Behavior after the end	Switching off ▼
Additional behavior when receiving a sequence "stop" telegram	<input checked="" type="radio"/> Switching off <input type="radio"/> Unchange
Behavior when receiving a switch on/ relative dimming/absolute dimming telegram	<input type="radio"/> Ignore, and keep running <input checked="" type="radio"/> Stop running
Behavior when receiving a switch "OFF" telegram	<input checked="" type="radio"/> Switching off and stop sequence <input type="radio"/> Ignore, and keep running

i The RGB value cannot be set to #000000

Number of step	7 ▼
Step 1	
RGB value	#FFFFFF
Pause time	0 ▲▼ s
Breathing time of the next step	4 ▲▼ s
Step 2	
RGB value	#FFFFFF
Pause time	0 ▲▼ s
Breathing time of the next step	4 ▲▼ s

Fig.4.3.4.3 Parameter window "Sequence X-{{0:...}},(X=1~4)"

Parameter "Description (max 30char.)"

This parameter is for setting the name description of the sequence, up to input 30 characters.

Parameter "Work mode"

This parameter is for setting the lamps work mode for the sequence. Options:

Breathing

Jumping

Dimming

Parameter "Assign Scene NO. to start sequence [1..64,0=no assignment] "

This parameter is for setting the assign scene number to start sequence. Options: **0..64**

Note: When 2 or more sequences are configured to conflict, the first conflicting scene is executed and the others scenes are ignored.

Parameter "Number of sequence execution (0=no limit)"

This parameter is for setting the number of sequence execution. Options: **0...255**

0: Unlimited cyclic sequences, unless interrupted by sequence start/stop objects or other control commands.

1: An acyclic sequence that is executed only once.

2..255: Loop sequence, after the last parameter step, the sequence will restart until the loop count is reached, ending the sequence.

Parameter "Behavior after the end"

In the case of a sequence with limited loop, sets the behavior after the end. Options:

Switching off

Start Sequence 1/2/3/4

Unchange

Sequence 1/2/3/4: When "Number of sequence executions" is greater than 1, it is visible. After the current sequence finishes running, continue with running another sequence, x.

Parameter "Additional behavior when receiving a sequence "stop" telegram"

This parameter is for setting the behavior when receiving a sequence "stop" telegram. Options:

Switching off

Unchange

Parameter "Behavior when receiving a switch on/relative dimming/absolute dimming telegram"

This parameter is for setting the sequence behavior when receiving a "switch on/relative dimming/absolute dimming" telegram.

When the lamps work mode is breathing, Options: **Ignore, and keep running/Stop running**

When the lamps work mode is "jumping" or "dimming", Options:

Execute and update step preset value, and keep running

Execute and not update step preset value, and keep running

Ignore, and keep running

Stop running

Note: 1. The sequence stop running when it receives a command for a extension function, such

as scene,forced.

2. When a "0" command is received, the sequence will only be executed and not saved.

Parameter "Behavior when receiving a switch "OFF" telegram"

This parameter is for setting the sequence behavior when receiving a switch "OFF" telegram. Options:

Switching off and stop sequence

Ignore, and keep running

Switching off and stop sequence: Switching off the lamp and stop sequence when receiving a switch "OFF" telegram.

Ignore, and keep running: Ignore and keep running sequence when receiving a switch "OFF" telegram.

Parameter "Number of step"

This parameter is for setting the number of steps for the sequence to run, up to 7. Options: 1...7

Note: There is no option "1" when "Dimming" and "Jumping" are selected for the lamp work mode.

Parameter "RGB value"

This parameter is for setting the RGB value. Options: #000000#FFFFFF

Note: The RGB value cannot be set to #000000, if not meet the condition, they cannot be configured in ETS, and display warning, as shown as follow:

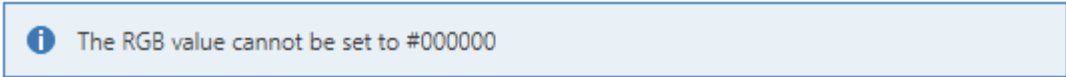

i The RGB value cannot be set to #000000

Parameter "Pause time"

When "Breathing" is selected for work mode, this parameter sets the pause time after the lamp of the current step is adjusted to the minimum brightness, and then adjust the brightness again to the target brightness value of the next step (this time is counted after the breathing period).

When "Jump" is selected for work mode, this parameter sets the pause time after switching to the target brightness value, and then immediately switch to the target brightness value of the next step.

When "Dimming" is selected for work mode, this parameter sets the pause time after reaching the target brightness value before starting to fade to the next target brightness value.

Options: 0...14400s

Parameter "Breathing time of the next step"

This parameter is visible when "Breathing" is selected. Set breathing time of the next step. This refers to the time of gradual change from the lowest brightness to the target value, and then from the target value to the lowest brightness. Options: 2.... .255s

Note: step1 is regulated at the start-up run of the sequence using the general dimming time until the next step which uses the breathing time set by this parameter, or if during the cycling of the sequence, the breathing time of step1 is determined by the definition of the parameter in the previous step (the last step of this or any other sequence).

Parameter "Transition time to the next step"

This parameter is visible when "Dimming" is selected. Set the dimming time from the current step's target brightness value to the next step's target brightness value (this time is counted after the pause time).

Note: When the sequence starts, step1 uses the general dimming time to adjust the target brightness value.

4.4 Parameter window "UI setting"

The parameter setting interface "UI setting" is shown as in Fig.4.4, here you can set the universal interface function, including dry contact input detection and LED output indicator. Generally, dry contact input detection is used to connect a conventional push button or switch panel or sensor, and LED output is used to connect with LED indicator. The combination of the two function can make the LED output to indicate the input status.

Universal interface setting

Function of Channel 1 Disable Input

Function of Channel 2 Disable Input

Function of Channel 3 Disable Input

Function of Channel 4 Disable Input

Function of Channel 5

Function of Channel 6

Function of Channel 7

Function of Channel 8

Common setting channel set as output LED

Output LED voltage 12V

The connect type for the LED Common Anode

LED object need send read request after power on

Brightness of LED

Debounce time ms

Fig.4.4 Parameter window“UI setting”

Universal interface setting

Parameter “Function of Channel x” (x=1~8)

This parameter is to set the function of channel.

Channel 1~4 Options: **Disable/Input**

Channel 5~8 Options:**Disable/Input /Output LED**

Common setting channel set as output LED

Parameter “Output LED voltage--12V”

This parameter is for setting the output LED voltage, option is only 12V.

Parameter “The connect type for the LED”

This parameter is for setting the connect type for the LED, option is only **Common Anode**

Parameter “LED object need send read request after power on”

This parameter is to set whether the LED object need send a read request after power on or ETS downloading.

When this parameter is enabled: Send a read request. And the LED will indicate accordingly to the responded value.

When this parameter is disabled: Do not send. And the following parameter "Initial LED status" is visible when you choose "No".

--Parameter "Initial status indication"

This parameter is visible when previous parameter is disable, set the initial LED status. Options:

No

As status as object value "0"

No: No indication.

As status as object value "0" : To indicate accordingly to the status when LED object value is 0. If "Status LED indication" selects "control by external object, and 1byte", there is no indication.

Parameter "Brightness of LED"

This parameter is for setting the brightness of the LED output indicator.If no indicator, it is off.

Options:

Level 1

Level 2

Level 3

Parameter "Debounce time"

This parameter is for setting the debounce time to avoid the unnecessary operations which is caused by the contact triggered multiple times in bouncing time, debounce time is the valid time of the contact operation. Options:

50ms

70ms

100ms

150ms

4.4.1Parameter window"Input X(X=1~8)"

Dry contact input detection support the functions of switch, dimming, value output, scene control, blind, shift register, multiple operation and delay mode. And the parameter settings and communication objects for each input are independent of each other. The following takes an input as an example for parameter description.

Description (max 30char.)

Function of channel

Fig.4.4.1 Parameter window "Input x-..."

Parameter "Description (max 30char.)"

This parameter is for setting the name description of the input channel, up to 30 characters.

Parameter "Function of channel"

This parameter is for setting the function of channel. Options:

- | | |
|----------------------|---------------------------|
| Switch | Blind |
| Dimming | Shift register |
| Value output | Multiple operation |
| Scene control | Delay mode |

4.4.1.1 Parameter window "Switch"

"Switch" parameter setting interface is shown as in Fig.4.4.1.1, user can press or release the contact to send a switch telegram with this application.

Description (max 30char.)	<input type="text"/>
Function of channel	Switch
Distinction between short and long operation	<input checked="" type="checkbox"/>
Long operation after [3..25]	5 *0.1s
Connected contact type	<input checked="" type="radio"/> Normally open <input type="radio"/> Normally closed
Reaction on short operation	TOGGLE
Reaction on long operation	TOGGLE
Number of objects	<input checked="" type="radio"/> 1 <input type="radio"/> 2
<hr/>	
Disable function	<input checked="" type="checkbox"/>
Trigger value of disable object	<input type="radio"/> Disable=1/Enable=0 <input checked="" type="radio"/> Disable=0/Enable=1

Fig.4.4.1.1 Parameter window“Input x-Switch”

Parameter “Distinction between short and long operation”

This parameter defines whether the contact use long/short operation or not. If select to distinguish, you should close the contact for a certain time, so it can be identified as long operation and execute corresponding action.

--Parameter “Long operation after [3..250]”

This parameter is visible when “distinction between short and long operation” is enable. Set the valid time for long operation. So, when you press longer than the time set here, it will be identified as long operation, otherwise, it will be taken as short operation. Options: **[3...250] *0.1s**

Parameter “Connect contact type”

This parameter is for setting the connect contact type. Options:

Normally open

Normally closed

Parameters explained in this chapter is taken **Normally open** as an example, operation of **Normally closed** is reversed.

Parameter “Reaction on short operation” / “Reaction on press the contact”

Parameter “Reaction on long operation” / “Reaction on release the contact”

These parameters are for setting the reaction on press/release the contact or on short/long operation. The object values are updated immediately when the input is confirmed. Options:

No action

ON

OFF

TOGGLE

No action: No telegram to be sent.

ON: Send "ON" telegram.

OFF: Send "OFF" telegram.

TOGGLE: each operation will toggle the switch between on and off. For example, if send an On telegram(or received) at the last, then the next operation will trigger an Off telegram. When the contact is operated again, it will send an On telegram, etc. So the contact will always remember the previous status and covert to opposite value during next operation. When the device is powered on for the first time or restarted after downloading, the default value for "Switch" is 0, meaning the first operation will be ON.

Parameter "Send object value after bus recovery (valid if reaction is not toggle)"

This parameter is visible when "distinction between short and long operation" is disable. Set whether to send the current value of object "Switch" to the bus after bus recovery.

If enabled, send the current value of object "Switch" to the bus after bus recovery, but it is only applied to the parameter "Reaction on press /release the contact" option is not "Toggle" or "No reaction", and if any one of the parameters select these two options can not send value to the bus.

Parameter "Number of objects"

This parameter is for setting the number of objects to control switch, 1 common object or 2 separate objects. Options:

1

2

Parameter "Disable function"

This parameter for setting whether to enable the disable function of the contact. The disable status is activated be default after download.

Without distinction between short and long operation: If the channel is disabled before release, no telegram is sent when released; Also, when the channel switches from disabled to enabled, no telegram is sent for the current contact state.

Distinction between short and long operation: When the channel switches from disabled to enabled, no telegram is sent for the current contact state.

--Parameter "Trigger value of disable object"

This parameter is visible when previous parameter is enabled. Set the trigger value of disable

object. Options:

Disable=1/enable=0

Disable=0/enable=1

4.4.1.2 Parameter window“Dimming”

Description (max 30char.)	<input type="text"/>
Function of channel	Dimming ▾
Long operation after [3..25]	5 *0.1s
Connected contact type	<input checked="" type="radio"/> Normally open <input type="radio"/> Normally closed
Reaction on short operation	TOGGLE ▾
Reaction on long operation	Brighter/Darker ▾
Dimming mode	<input checked="" type="radio"/> Start-Stop dimming <input type="radio"/> Step dimming
Disable function	<input checked="" type="checkbox"/>
Trigger value of disable object	<input type="radio"/> Disable=1/Enable=0 <input checked="" type="radio"/> Disable=0/Enable=1

Fig.4.4.1.2 Parameter window“Input x- Dimming”

Parameter “Reaction on short operation”

This parameter is for setting the reaction on short operation. Options:

No action

ON

OFF

TOGGLE

No action: No telegram to be sent.

ON: Send “ON” telegram.

OFF: Send “OFF” telegram.

TOGGLE: Each operation will toggle the switch between on and off. When the device is powered on for the first time or restarted after downloading, the default value for ” Switch ” is 0, meaning the first operation will be ON.

Parameter “Reaction on long operation”

This parameter is used to send the relative dimming value (up or down) during long operation, releasing the contact will stop the dimming, Options:

Options:

No action

Brighter

Darker

Brighter/Darker

No action: No telegram to be sent.

Brighter: Send the dimming up value.

Darker: Send the dimming down value.

Brighter/darker: Each operation will toggle the dimming between up and down. When the device is powered on for the first time or restarted after downloading, the default value for "Dimming" is 0, meaning the first operation is dim up the brightness.

Note: In the options of "TOGGLE" and "Brighter/Darker", there are a linkage between the received switch status and the dimming. For example, if receive an On value from object "Switch" at the last, then it will dim down the brightness in next dimming operation. If receive an Off value first, then it will dim up the brightness in next dimming operation.

In "Start-stop dimming" mode, the device receives a telegram in the opposite direction when it is long-pressed (such as, sending dimming telegram). Then, when the device is released, the stop telegram will be sent in the same direction as the latest received relative dimming.

In "Step dimming" mode, the device receives a telegram in the opposite direction when it is long-pressed (such as, sending dimming telegram periodically). Then when the device is released, the stop telegram will be sent in the same direction as the latest sent/received relative dimming.

The periodically sent telegram is based on the initial dimming telegram sent by the device as a reference.

Parameter "Dimming mode"

This parameter is for setting the mode of relative dimming. Options:

Start-stop dimming

Step dimming

Start-stop dimming: The dimming mode is start-stop, a telegram of dimming up or down will be sent when the dimming starts, and a stop telegram will be sent when dimming ends. The dimming telegram is no need to be sent cyclically.

Step dimming: The dimming mode is step and the dimming telegram is sent cyclically. When dimming ends, a stop dimming telegram will be sent immediately.

--Parameter "Step size"

This parameter is visible when "Step dimming" is selected. Set the brightness (%) that can be changed by the dimming telegrams sent cyclically. Options:

100%

...

1.56%

--Parameter "Interval of tele. Cyclic send [0..25] (0=send once)"

This parameter is visible when "Step dimming" is selected. Set the interval for cyclically sending the telegram of dimming. Options: **[0..25] *0.1s, 0=send once**

Parameter "Disable function"

This parameter for setting whether to enable the disable function of the contact. The disable status is activated by default after download.

When the channel switches from disabled to enabled, no telegram is sent for the current contact state; The channel is disabled when pressed, the cyclically sent telegram will stop, and even if the channel is enabled before release, no more long operation telegram will be sent. However, if the long operation was triggered before the channel was disabled, a stop dimming telegram will be sent in this case.

--Parameter "Trigger value of disable object"

This parameter is visible when the previous parameter is enabled. Set the trigger value of the disable object. Options:

Disable=1/enable=0

Disable=0/enable=1

4.4.1.3 Parameter window "Value output"

Description (max 30char.)	<input type="text"/>
Function of channel	Value output ▾
Distinction between short and long operation	<input checked="" type="checkbox"/>
Long operation after [3..25]	5 *0.1s
Connected contact type	<input checked="" type="radio"/> Normally open <input type="radio"/> Normally closed
Reaction on short operation	1Bit value[0..1] ▾
Output value [0..1]	0
Reaction on long operation	1Bit value[0..1] ▾
Output value [0..1]	0
Disable function	<input checked="" type="checkbox"/>
Trigger value of disable object	<input type="radio"/> Disable=1/Enable=0 <input checked="" type="radio"/> Disable=0/Enable=1

Fig.4.4.1.3 Parameter window "Input x}- Value output"

Parameter "Reaction on short operation" / "Reaction on press the contact"

Parameter "Reaction on long operation" / "Reaction on release the contact"

These parameters are for setting the object datatype to be sent when on press/release the contact or on short/long operation. Options:

- No reaction**
- 1Bit value [0..1]**
- 2Bit value [0..3]**
- 4Bit value [0..15]**
- 1Byte value [0..255]**
- 2Byte value [0..65535]**

--Parameter "Output value [...]"

These parameters are for setting the output value when execute the operation. Range of value is according to the selection of previous parameter.

Parameter "Disable function"

This parameter for setting whether to enable the disable function of the contact. The disable status is activated by default after download.

Without distinction between short and long operation: If the channel is disabled before release, no

telegram is sent when released; Also, when the channel switches from disabled to enabled, no telegram is sent for the current contact state.

Distinction between short and long operation: When the channel switches from disabled to enabled, no telegram is sent for the current contact state.

--Parameter "Trigger value of disable object"

This parameter is visible when previous parameter is enabled. Set the trigger value of disable object. Options:

Disable=1/enable=0

Disable=0/enable=1

4.4.1.4 Parameter window "Scene control"

Description (max 30char.)	<input type="text"/>
Function of channel	Scene control
Distinction between short and long operation	<input checked="" type="checkbox"/>
Long operation after [3..25]	5 *0.1s
Connected contact type	<input checked="" type="radio"/> Normally open <input type="radio"/> Normally closed
Reaction on short operation	Recall scene
8 bit scene number	Scene NO.1
Reaction on long operation	Store scene
8 bit scene number	Scene NO.1
Number of objects	<input checked="" type="radio"/> 1 <input type="radio"/> 2
Disable function	<input checked="" type="checkbox"/>
Trigger value of disable object	<input type="radio"/> Disable=1/Enable=0 <input checked="" type="radio"/> Disable=0/Enable=1

Fig.4.4.1.4 Parameter window "Input x- Scene control"

Parameter "Reaction on short operation" / "Reaction on press the contact"

Parameter "Reaction on long operation" / "Reaction on release the contact"

These parameters are for setting the reaction on short/long the contact or on press/release

operation, to recall or store scene. Options:

No reaction

Recall scene

Store scene

--Parameter "8 bit scene number"

This parameter is for setting the scene number. Options: **Scene NO.1~64**, corresponding telegram is 0~63.

Parameter "Number of objects"

This parameter is for setting the number of objects to recall/store scene, 1 common object or 2 separate objects. Options:

1

2

Parameter "Disable function"

This parameter for setting whether to enable the disable function of the contact. The disable status is activated by default after download.

Without distinction between short and long operation: If the channel is disabled before release, no telegram is sent when released; Also, when the channel switches from disabled to enabled, no telegram is sent for the current contact state.

Distinction between short and long operation: When the channel switches from disabled to enabled, no telegram is sent for the current contact state.

--Parameter "Trigger value of disable object"

This parameter is visible when previous parameter is enabled. Set the trigger value of disable object. Options:

Disable=1/enable=0

Disable=0/enable=1

4.4.1.5 Parameter window "Blind"

Description (max 30char.)	<input type="text"/>
Function of channel	<input type="text" value="Blind"/>
Long operation after [3..25]	<input type="text" value="5"/> *0.1s
Connected contact type	<input checked="" type="radio"/> Normally open <input type="radio"/> Normally closed
Reaction on short operation	<input type="text" value="Up/Down"/>
Reaction on long operation	<input type="text" value="Stop(Adjust Up/Down)"/>
Interval of tele. cyclic send [0..25] (0=send once)	<input type="text" value="0"/> *0.1s
<hr/>	
Disable function	<input checked="" type="checkbox"/>
Trigger value of disable object	<input type="radio"/> Disable=1/Enable=0 <input checked="" type="radio"/> Disable=0/Enable=1

Fig.4.4.1.5Parameter window "Input x- Blind"

Parameter "Reaction on short/long operation"

These parameters are for setting the reaction on short/long operation. Options:

- No action**
- Up**
- Down**
- Up/Down**
- Stop (Adjust Up)**
- Stop (Adjust Down)**
- Stop (Adjust Up/Down)**

No action: No telegram to be sent.

Up: The blinds will be opened or moved up.

Down: The blinds will be closed or moved down.

Up/Down: Alternately open/close or move up/down the blinds. When the device is powered on for the first time or restarted after downloading, the default value for "Up/Down, Blind" is 0, meaning the first operation will be closing or moving down the blinds.

Stop (Adjust Up): Stop the blind movement or move up the angle of blinds.

Stop (Adjust Down): Stop the blind movement or move down the angle of blinds.

Stop (Adjust Up/Down): Stop the blind movement or move up/down the angle of blinds alternately. When the device is powered on for the first time or restarted after downloading, the default value for "Stop/Adjust Blind" is 0, meaning the first operation will be stop or move down the angle of blinds.

Note: In "Stop (Adjust...)" mode, the device receives a telegram in the opposite direction when it is long-pressed (such as, sending build telegram periodically). Then when the device is released, the stop telegram will be sent in the same direction as the latest received build.

The periodically sent telegram is based on the initial build telegram sent by the device as a reference.

--Parameter "Interval of tele. cyclic send [0..25] (0=send once)"

This parameter is visible when previous parameter is selected "Stop...". Set the interval for cyclically sending the telegram of blinds angle adjustment. Options: **[0..25],0=send once**

Parameter "Disable function"

This parameter for setting whether to enable the disable function of the contact. The disable status is activated by default after download.

When the channel switches from disabled to enabled, no telegram is sent for the current contact state; If the channel is disabled before release, no more long operation telegram will be sent periodically.

--Parameter "Trigger value of disable object"

This parameter is visible when previous parameter is enabled. Set the trigger value of disable object. Options:

Disable=1/enable=0

Disable=0/enable=1

4.4.1.6 Parameter window "Shift register"

Description (max 30char.)	<input type="text"/>
Function of channel	<input type="text" value="Shift register"/>
Shift type	<input checked="" type="radio"/> Shift by step value <input type="radio"/> Shift without step value
Value begin with	<input type="text" value="0"/>
Value end with(must be larger than value begin with)	<input type="text" value="10"/>
Step size	<input type="text" value="2"/>
Direction	<input type="text" value="From lowest to highest and cyclically"/>
Reset function	<input type="radio"/> Disable <input checked="" type="radio"/> Enable by long operation
Long operation after [3..25]	<input type="text" value="5"/> *0.1s
Connected contact type	<input checked="" type="radio"/> Normally open <input type="radio"/> Normally closed
<hr/>	
Disable function	<input checked="" type="checkbox"/>
Trigger value of disable object	<input type="radio"/> Disable=1/Enable=0 <input checked="" type="radio"/> Disable=0/Enable=1

Fig.4.4.1.6 Parameter window "Input x- Shift register"

Parameter "Shift type"

This parameter is for setting the shift type. Options:

Shift by step value

Shift without step value

Shift by step value: set the lowest and highest value of shift, as well as the value increased (from lowest to highest) or decreased (from highest to lowest) from each shift.

Shift without step value: when there is no step value, set the actual value sent by each shift (max. 10 values), operate a time and send a value.

Parameters as follow are visible when "Shift by step value" is selected.

--Parameter "Value begin with"

This parameter is for setting the lowest value of the shift. Options: **0..240**

--Parameter "Value end with(must be larger than value begin with)"

This parameter is for setting the highest value of the shift. Options: **1..255**

Note: the highest value must be larger than lowest value, if not, it can not set on the ETS and

display the red box, as shown as following:

Value begin with	<input type="text" value="4"/>
Value end with(must be larger than value begin with)	<input type="text" value="1"/>

--Parameter "Step size"

This parameter is for setting the increase (from low to high) or decrease (from high to low) value from each shift. Options: **0..240**

Parameters as follow are visible when "Shift without step value" is selected.

--Parameter "Object datatype"

This parameter is for setting the object datatype for the shift object. Options:

- 1byte unsigned value**
- Scene number**
- HVAC mode**

--Parameter "Shift number"

This parameter is for setting the number of shift, up to set maximum 10 values.

When "1byte unsigned value", "Scene number" or "1byte percentage" is selected, options:

0/1/2/.../10

When "HVAC mode" is selected, options: **1/2/3/4**

--Parameter "Value x" (x=1~10 或 x=1~4)

This parameter is for setting the value when each shift operation to send.

When "1byte unsigned value" is selected, options: **0...255**

When "Scene number" is selected, options:

- Scene NO.1**
- Scene NO.2**
- Scene NO.3**
- ...
- Scene NO.64**

When "HVAC mode" is selected, options:

- Comfort mode**
- Standby mode**
- Economy mode**
- Frost/heat protection**

Parameter "Direction"

This parameter is for setting the shift direction. Options:

From lowest to highest and stop to the end

From highest to lowest and stop to the begin

From lowest to highest and cyclically

From highest to lowest and cyclically

From lowest to highest and stop to the end: Shift from low to high.

From highest to lowest and stop to the begin: Shift from high to low.

From lowest to highest and cyclically: Once to the end value, shift direction starts over again and constantly cycling from low to high operation.

From highest to lowest and cyclically: Once to the start value, shift direction starts over again and constantly cycling from high to low operation.

Parameter "Reset function"

This parameter is for setting whether to enable shift reset function. Options:

Disable

Enable by long operation

Disable: Not possible to reset shift.

Enable by long operation: Possible to reset shift by long operation, when reset, shift will be restarted.

Parameter "Disable function"

This parameter for setting whether to enable the disable function of the contact. The disable status is activated by default after download.

Without distinction between short and long operation: If the channel is disabled before release, no telegram is sent when released; Also, when the channel switches from disabled to enabled, no telegram is sent for the current contact state.

Distinction between short and long operation: When the channel switches from disabled to enabled, no telegram is sent for the current contact state.

--Parameter "Trigger value of disable object"

This parameter is visible when previous parameter is enabled. Set the trigger value of disable object. Options:

Disable=1/enable=0

Disable=0/enable=1

4.4.1.7 Parameter window "Multiple operation"

Description (max 30char.)	<input type="text"/>
Function of channel	Multiple operation ▼
Distinction between short and long operation	<input checked="" type="checkbox"/>
Long operation after [3..25]	5 *0.1s
Connected contact type	<input checked="" type="radio"/> Normally open <input type="radio"/> Normally closed
Object type for object1	1Bit_On/Off ▼
Function of short operation	TOGGLE ▼
Function of long operation	TOGGLE ▼
Object type for object2	1Bit_On/Off ▼
Function of short operation	TOGGLE ▼
Function of long operation	TOGGLE ▼
Object type for object3	1Bit_On/Off ▼
Function of short operation	TOGGLE ▼
Function of long operation	TOGGLE ▼
Object type for object4	1Bit_On/Off ▼
Function of short operation	TOGGLE ▼
Function of long operation	TOGGLE ▼
Disable function	<input checked="" type="checkbox"/>
Trigger value of disable object	<input type="radio"/> Disable=1/Enable=0 <input checked="" type="radio"/> Disable=0/Enable=1

Fig.4.4.1.7 Parameter window "Input x- Multiple operation"

Parameter "Object type for object x" (x=1...4)

These parameters are for setting the object datatype to be sent when on close the contact or on short/long operation. Options:

- Disable
- 1Bit_On/Off
- 1Bit_Up/Down
- 1Byte_RecallScene
- 1Byte_StoreScene
- 1Byte_Percentage

1Byte_Unsigned value

1Bit_On/Off: When the device is powered on for the first time or restarted after downloading, the default value for " On/Off" is 0, meaning the first operation will be ON.

1Bit_Up/Down: When the device is powered on for the first time or restarted after downloading, the default value for " Up/Down" is 0, meaning the first operation will be closing or moving down the blinds.

Parameter "Function of short operation" / "Function of press the contact"

Parameter "Function of long operation"

These parameters are for setting the specific values to send when perform the operation, either no action or sending value (the specific value will be set in next parameter).

--Parameter "Value 1/2 (...)"

These parameters are visible when "1Byte_RecallScene","1Byte_StoreScene","1Byte_Percentage" or "1Byte_Unsigned value" is selected. Set the sending values when perform operations. The ranges of value 1/2 are depending on the datatype selected by the parameter before last one.

Parameter "Disable function"

This parameter for setting whether to enable the disable function of the contact. The disable status is activated by default after download.

When the channel switches from disabled to enabled, no telegram is sent for the current contact state.

--Parameter "Trigger value of disable object"

This parameter is visible when previous parameter is enabled. Set the trigger value of disable object. Options:

Disable=1/enable=0

Disable=0/enable=1

4.4.1.8 Parameter window "Delay mode"

Description (max 30char.)	<input type="text"/>
Function of channel	<input type="text" value="Delay mode"/>
Distinction between short and long operation	<input checked="" type="checkbox"/>
Long operation after [3..25]	<input type="text" value="5"/> *0.1s
Connected contact type	<input checked="" type="radio"/> Normally open <input type="radio"/> Normally closed
Object type for short operation	<input type="text" value="1Bit_On/Off"/>
Send mode	<input type="text" value="No action when press,delay then send value1"/>
Delay time [0..6500]	<input type="text" value="10"/> s
Value 1	<input checked="" type="radio"/> 0 <input type="radio"/> 1
Value 2	<input type="radio"/> 0 <input checked="" type="radio"/> 1
Object type for long operation	<input type="text" value="1Bit_On/Off"/>
Send mode	<input type="text" value="No action when press,delay then send value1"/>
Delay time [0..6500]	<input type="text" value="10"/> s
Value 1	<input checked="" type="radio"/> 0 <input type="radio"/> 1
Value 2	<input type="radio"/> 0 <input checked="" type="radio"/> 1
Disable function	<input checked="" type="checkbox"/>
Trigger value of disable object	<input type="radio"/> Disable=1/Enable=0 <input checked="" type="radio"/> Disable=0/Enable=1

Fig.4.4.1.8Parameter window "Input x- Delay mode"

Parameter "Object type for press the contact"

Parameter "Object type for short operation"

Parameter "Object type for long operation"

These parameters are for setting the object datatype to be sent when on press the contact or on short/long operation. Options:

Disable

1Bit_On/Off

4Bit_Dimming

1Byte_Unsigned value

--Parameter "Send mode"

This parameter is for setting the send mode. Options:

No action when press, delay then send value 1

No action when press, delay then send value 2

Send value 1 when press, delay then send value 2

Send value 2 when press, delay then send value 1

--Parameter "Delay time [0..6500]"

This parameter is for setting the delay time. Options: **0..6500 s**

--Parameter "value1/2 [...]"

This parameter is for setting the value 1/2 to send. The ranges of value 1/2 are depending on the datatype selected by the parameter before last one.

Parameter "Disable function"

This parameter for setting whether to enable the disable function of the contact. The disable status is activated by default after download.

When the channel switches from disabled to enabled, no telegram is sent for the current contact state.

--Parameter "Trigger value of disable object"

This parameter is visible when previous parameter is enabled. Set the trigger value of disable object. Options:

Disable=1/enable=0

Disable=0/enable=1

4.4.2 Parameter window "LED x"

This parameter window is used to set the LED function. Each input provide a LED indication. Each LED can be set separately. Take one of the LED for detailed explanation.

Fig.4.4.2 Parameter window“LED x”

Parameter “Status LED indication”

This parameter is for setting the LED indication status. Options:

None

Control by external object

Always on

None: Deactivating LED function.

Control by external object: The LED indication can be controlled independently;It will be not influenced by the contact functions.

--Parameter “External object datatype”

This parameter is available when “Control by external object “ is selected. It is used for setting the data type of the LED object, Options:

1bit

1byte

--Parameter “When object value =‘0/1’, LED is”

This parameter is available when “Control by external object “ and “1Bit” is selected. The LED indicates the value of the switching object for the contact input function or the value of the telegram received by the LED object, “1” or “0”,Options:

OFF

ON

--Parameter “Threshold value is”

This parameter is available when “Control by external object “ and “1Byte” is selected. It is used for setting the threshold value of the LED indication. Options:1...255

--Parameter "If object value<threshold value, LED is"

This parameter is available when "Control by external object " and "1Byte" is selected. It is used for setting the status of the LED indication when the object value is smaller than the threshold value.

Options:

OFF

ON

--Parameter "If object value=threshold value, LED is"

This parameter is available when "Control by external object " and "1Byte" is selected. It is used for setting the status of the LED indication when the object value is the same with the threshold value.

Options:

OFF

ON

--Parameter "If object value>threshold value, LED is"

This parameter is available when "Control by external object " and "1Byte" is selected. It is used for setting the status of the LED indication when the object value is larger than the threshold value.

Options

OFF

ON

Chapter 5 Description of Communication Object

The communication object is the medium through which the device communicates with other devices on the bus, that is, only the communication object can perform bus communication.

The function of each communication object of each function block is described in detail below.

Note: "C" in the property bar of the table below represents the communication function of the communication object.

"W" represents the value of the communication object can be rewritten by the bus.

"R" represents the value of the communication object can be read through the bus.

"T" stands for communication object with transmission function.

"U" means that the value of the communication object can be updated.

5.1 Communication object of "General"

	Number ^	Name	Object Function	Description	Group Address	Length	C	R	W	T	U	Data Type	Priority
↔	1	General	In operation			1 bit	C	R	-	T	-	switch	Low
↔	5	General	Central: Safety			1 bit	C	-	W	-	-	alarm	Low

Fig.5.1 Communication object of "General"

NO.	Object Function	Name	Data Type	Flag	DPT
1	In operation	General	1bit	C,R,T	1.001 switch
<p>The communication object is used to periodically send a telegram "1" to the bus to indicate that the device is working properly.</p>					
5	Central: Safety	General	1bit	C,W	1.005 alarm
<p>The communication object is used to receive the 1bit telegram that is sent from other device (such as sensor, controller, etc.), the cancel telegram value is decided by the parameter.</p> <p>If no corresponding telegram is received within the monitoring time, it is assumed that other devices are failure, and the channel with a safety function activates the safety operation. With a monitoring time of 0, it is also possible to activate and exit the safety operation by receiving the corresponding value with this object.</p> <p>In the case that the safety operation is not active, the cancel telegram is meaningless and it will be ignored.</p>					

Table5.1 Communication object of "General"

5.2 Communication object of "Output setting"

5.2.1 Communication object of "Dimming X(X=A,B,C)"

	Number ^	Name	Object Function	Description	Group Address	Length	C	R	W	T	U	Data Type	Priority
➤	54	Dimming A-...	Switching			1 bit	C	-	W	-	-	switch	Low
➤	55	Dimming A-...	Relative dimming			4 bit	C	-	W	-	-	dimming control	Low
➤	56	Dimming A-...	Absolute dimming			1 byte	C	-	W	-	-	percentage (0..100%)	Low
➤	57	Dimming A-...	Switching, status			1 bit	C	R	-	T	-	switch	Low
➤	58	Dimming A-...	Brightness value, status			1 byte	C	R	-	T	-	percentage (0..100%)	Low
➤	64	Dimming A-...	Scene			1 byte	C	-	W	-	-	scene control	Low
➤	65	Dimming A-...	Staircase lighting			1 bit	C	-	W	-	-	start/stop	Low
➤	68	Dimming A-...	Threshold input			2 bytes	C	-	W	-	-	lux (Lux)	Low
➤	71	Dimming A-...	Forced operation			1 bit	C	-	W	-	-	switch	Low
➤	73	Dimming A-...	Start/stop sequence 1			1 bit	C	-	W	-	-	start/stop	Low
➤	74	Dimming A-...	Sequence 1, status			1 bit	C	R	-	T	-	start/stop	Low
➤	75	Dimming A-...	Start/stop sequence 2			1 bit	C	-	W	-	-	start/stop	Low
➤	76	Dimming A-...	Sequence 2, status			1 bit	C	R	-	T	-	start/stop	Low
➤	77	Dimming A-...	Start/stop sequence 3			1 bit	C	-	W	-	-	start/stop	Low
➤	78	Dimming A-...	Sequence 3, status			1 bit	C	R	-	T	-	start/stop	Low
➤	79	Dimming A-...	Start/stop sequence 4			1 bit	C	-	W	-	-	start/stop	Low
➤	80	Dimming A-...	Sequence 4, status			1 bit	C	R	-	T	-	start/stop	Low

Fig.5.2.1 Communication object of "Dimming X(X=A,B,C)"

NO.	Object Function	Name	Data Type	Flag	DPT				
54	Switching	Dimming A-{{...}}	1bit	C,W	1.001 switch				
<p>The communication object is used to receive a command of switching on/off lamps. Telegrams:</p> <p>1——Switch on</p> <p>0——Switch off</p> <p>The name in parentheses changes with the parameter "Description (max 30char.)". If description is empty, display "Dimming A - ..." by default. The same below.</p>									
55	Relative dimming	Dimming A-{{...}}	4bit	C,W	3.007 dimming				
<p>The communication object is used to receive a command of relative dimming, to dim up or dim down.</p> <p>Dimming down when telegram is 1~7, and the larger this range the adjust step is smaller. That is, the maximum step of dimming down when is 1, and the minimum step of dimming down when is 7, stop dimming when is 0;</p> <p>Dimming up when telegram is 9~15, and the larger this range the adjust step is smaller. That is, the maximum step of dimming up when is 9, and the minimum step of dimming up when is 15, stop dimming when is 8.</p> <p>The correspondence between the value of the relatively dimming telegram and brightness chance is as follows:</p>									
	Telegram	0	1	2	3	4	5	6	7

	value																												
	Decrease	stop	(100%)	(50%)	(25%)	(12%)	(6%)	(3%)	(1%)																				
	Telegram value	8	9	10	11	12	13	14	15																				
	Increase	stop	(100%)	(50%)	(25%)	(12%)	(6%)	(3%)	(1%)																				
56	Absolute dimming		Dimming A-{{...}}	1byte	C,W	5.001 percentage																							
<p>The communication object is used to receive a command of absolute dimming. Telegrams: 0...100%</p>																													
57	Switching, status		Dimming A-{{...}}	1bit	C,R,T	1.001 switch																							
<p>The communication object is used to report the status of the current switch to the bus. Send "1" to the bus when the value of the brightness is larger than 0, send "0" to the bus with value of "0". Send the status when voltage recovery.</p>																													
58	Brightness value, status		Dimming A-{{...}}	1byte	C,R,T	5.001 percentage																							
<p>The communication object is used to report the status of the current brightness value to the bus. Send the status at power-up when voltage recovery.</p>																													
64	Scene		Dimming A-{{...}}	1byte	C,W	18.001 scene control																							
<p>The communication object is used to receive a 8 bit command to recall or storage scene. Detailed 8bit the meaning of the directive. Set up a 8bit Orders for the (Binary code): FXNNNNNN F: '0' recall scene; '1' for storage scene; X : 0 ; NNNNNN: Scene number(0... 63).</p> <p>As follows:</p>																													
<table border="1"> <thead> <tr> <th>Object message value</th> <th>Description</th> </tr> </thead> <tbody> <tr> <td>0</td> <td>Recall scene 1</td> </tr> <tr> <td>1</td> <td>Recall scene 2</td> </tr> <tr> <td>2</td> <td>Recall scene 3</td> </tr> <tr> <td>...</td> <td>...</td> </tr> <tr> <td>63</td> <td>Recall scene 64</td> </tr> <tr> <td>128</td> <td>Store scene 1</td> </tr> <tr> <td>129</td> <td>Store scene 2</td> </tr> <tr> <td>130</td> <td>Store scene 3</td> </tr> <tr> <td>...</td> <td>...</td> </tr> </tbody> </table>										Object message value	Description	0	Recall scene 1	1	Recall scene 2	2	Recall scene 3	63	Recall scene 64	128	Store scene 1	129	Store scene 2	130	Store scene 3
Object message value	Description																												
0	Recall scene 1																												
1	Recall scene 2																												
2	Recall scene 3																												
...	...																												
63	Recall scene 64																												
128	Store scene 1																												
129	Store scene 2																												
130	Store scene 3																												
...	...																												

		191	Store scene 64		
<p>Parameter setting Options are 1~64, actually communication object "Scene" corresponds to the telegram received is 0~63. Such as parameter settings is the scene 1, communication object "Scene" sends the scene for 0.</p>					
65	Delay switch	Dimming A-{{...}}	1bit	C,W	1.001 switch
<p>The communication object is visible when "Delay switch" is selected for time function, used to turn on the function of delay switch.</p>					
65	Flashing switch	Dimming A-{{...}}	1bit	C,W	1.010 start/stop
<p>The communication object is visible when "Flashing switch" is selected for time function, used to turn on the function of flashing switch.</p>					
65	Staircase lighting	Dimming A-{{...}}	1bit	C,W	1.010 start/stop
<p>The communication object is visible when "Staircase lighting" is selected for time function, used to turn on the function of staircase lighting.</p>					
66	Duration of staircase lighting (5..65535s)	Dimming A-{{...}}	2byte	C,W,R	7.005time(s)
<p>The communication object is visible when "Staircase lighting" is selected for time function and duration time can be changed via bus. Used to modify the time, and save it after voltage failure. If the duration has not been modified, the value read from the object is the setting value of ETS parameter.</p>					
67	Staircase lighting Prewarning	Dimming A-{{...}}	1bit	C,R,T	1.005 alarm
<p>The communication object is visible when "Staircase lighting" is selected for time function and prewarn via bus. Used to send the telegram of prewarning before staircase lighting end. Telegram:</p> <p>1——Warning</p> <p>0——End of warning</p>					
68	Threshold input	Dimming A-{{...}}	1byte 2byte	C,W	5.010 counter pulses(0..255) 5.001 percentage 9.001 temperature 9.004 brightness (lux)
<p>The communication object is receive the input value of threshold function. Telegram value is determined by the datatype, and the datatype is determined by the parameter setting.</p>					
69	Threshold value 1	Dimming A-{{...}}	1byte 2byte	C,W,R	5.010 counter pulses(0..255) 5.001 percentage 9.001 temperature 9.004 brightness (lux)

70	Threshold value 2	Dimming A-{{...}}	1byte 2byte	C,W,R	5.010 counter pulses(0..255) 5.001 percentage 9.001 temperature 9.004 brightness (lux)
<p>These two communication objects are visible when the threshold value 1/2 can be changed via bus. Used to modify the values, and save them after voltage failure. If the thresholds have not been modified, the value read from the object is the setting value of ETS parameter.</p> <p>Note: threshold value 1 must be less than threshold value 2, or ignore the telegram.</p>					
71	Forced operation	Dimming A-{{...}}	1bit 2bit	C,W	1.003 enable 2.001 DPT_Switch control
<p>The communication object is used to trigger a forced operation. Save the trigger status when voltage failure, and keep the status at voltage recovery.</p> <p>When 1bit, activate the forced operation when receive telegram 1, at this time, ignore all the other actions; End the forced operation when receive telegram 0, and the behaviour in forced operation is defined by parameter.</p> <p>When 2bit, force to switch on when receive telegram 3; force to switch off when receive telegram 2; End the forced operation when receive telegram 1 or 0.</p> <p>Note: The end telegram is invalid when the forced operation is not active, and ignore it directly.</p>					
72	Sequence scene	Dimming A-{{...}}	1byte	C,W	17.001 scene number
<p>The communication object recall the sequence function through a scene number.</p>					
73/ 75/ 77/ 79	Start/stop sequence 1 Start/stop sequence 2 Start/stop sequence 3 Start/stop sequence 4	Dimming A-{{...}}	1bit	C,W	1.010 start/stop
<p>The communication object is used to control the start/stop sequences. Telegram:</p> <p>1: Start 0: Stop</p>					
74/ 76/ 78/ 80	Sequence 1, status Sequence 2, status Sequence 3, status Sequence 4, status	Dimming A-{{...}}	1bit	C,R,T	1.010 start/stop
<p>The communication object is used to send the sequences status. Telegram:</p> <p>1: Start 0: Stop</p> <p>Note: The brightness status during sequence execution sends the brightness status when the target brightness value is reached at each step of the sequence, and only sends when the brightness</p>					

changes.

Table 5.2.1 Communication object of "Dimming X(X=A,B,C)"

5.2.2 Communication object of "Switch X(X=A,B)"

序号 ^	名称	对象功能	描述	群组地址	长度	C	R	W	T	U	数据类型	优先级
182	Switching A-...	Switch			1 bit	C	-	W	-	-	switch	低
183	Switching A-...	Switch status			1 bit	C	R	-	T	-	switch	低
184	Switching A-...	Enable time function			1 bit	C	-	W	-	-	enable	低
185	Switching A-...	Delay function			1 bit	C	-	W	-	-	switch	低
186	Switching A-...	Operation hours counter			4 bytes	C	R	W	T	U	time lag (s)	低
187	Switching A-...	Scene			1 byte	C	-	W	-	-	scene control	低
188	Switching A-...	Forced output			1 bit	C	-	W	-	-	enable	低
189	Switching A-...	Logic 1			1 bit	C	-	W	-	-	boolean	低
190	Switching A-...	Logic 2			1 bit	C	-	W	-	-	boolean	低
185	Switching A-...	Flashing function			1 bit	C	-	W	-	-	switch	低
185	Switching A-...	Staircase function			1 bit	C	-	W	-	-	switch	低

Fig. 5.2.2 Communication object of "Switch X(X=A,B)"

NO.	Object Function	Name	Data Type	Flag	DPT
182	Switch	Switch A-{{...}}	1bit	C,W	1.001 DPT_Switch

This communication object is used to trigger the switch operation.

When "input 0" in the logic function is enabled, The communication object "switch" is not directly used to trigger the switch operation., the action of the switch will be affected by the logic function. Please refer to the following flow chart for details:

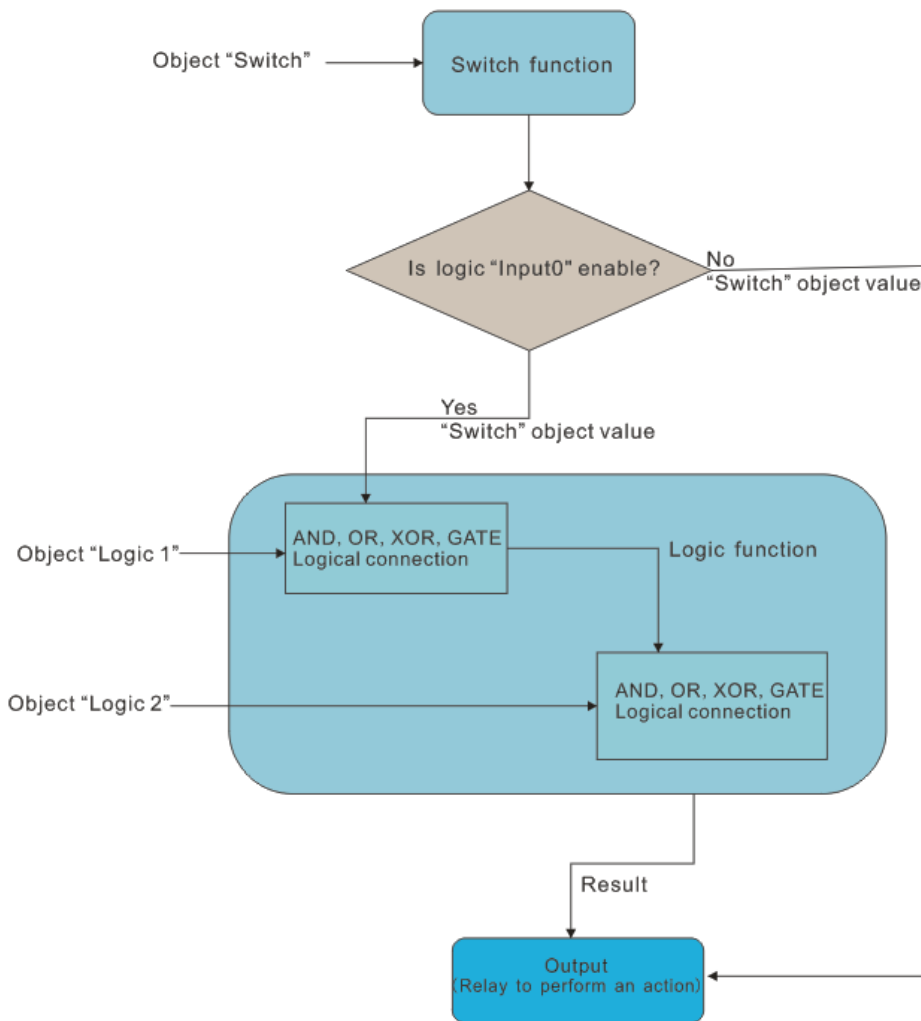

183	Switch status	Switch A-{{...}}	1bit	C,R,T	1.001 DPT_Switch
<p>The value of this communication object (Specifically set in the parameter "Object value of switch status:" in Figure 4.3.2(1) "Switch X") Can directly indicate the status of the relay contacts.</p> <p>If you choose "Respond after read only", only when the device receives a request from the bus to read the status of the channel switch, this object sends the current switch state to the bus;</p> <p>If you choose "Respond after change", when the switching state of the channel changes, This object immediately sends the current switch state to the bus.</p>					
184	Enable time function	Switch A-{{...}}	1bit	C,W	1.003 DPT_Enable
<p>The communication object is enabled when the time function is enabled. Time function can be prohibited by this communication object, When the communication object receives a message with a logical value of "1", the time function is enabled; When the telegram of "0" is received, clear the current timer, stop running and</p>					

ignore the delayed operation.					
When the time function is turned on, the time function is enabled by default when the bus resumes power supply.					
185	Delay function	Switch A-{{...}}	1bit	C,W	1.001 DPT_Switch
The communication object is enabled when the parameter "Type of time function" is selected as "Delay", and the delay switch is turned on by this communication object.					
185	Flashing function	Switch A-{{...}}	1bit	C,W	1.001 DPT_Switch
The communication object is enabled when "Flashing" is selected in the parameter "Type of time function", and the flashing switch is turned on by this communication object.					
185	Staircase function	Switch A-{{...}}	1bit	C,W	1.001 DPT_Switch
The communication object is enabled when the parameter "Type of time function" is selected as "Staircase", and the stair light function is activated by this communication object.					
186	Operation hours counter	Switch A-{{...}}	2byte 4byte	C,R,W, T,U	7.007 DPT_TimePeriodHrs 13.100 DPT_LongDeltaTimeSec
This communication object is used to report the time when the load of this loop is powered on, Displayed when "Enable" is selected in the parameter "Function of "Operation hours counter"", data type can be selected by "Object data type of "Operation hours counter"", the unit of 2byte type is hour, and the unit of 4byte is second.					
187	Scene	Switch A-{{...}}	1byte	C,W	18.001 DPT_SceneControl

The scene can be called or stored by sending an 8-bit instruction through this communication object. This communication object is enabled as long as the scene function is enabled. The meaning of the 8-bit instruction is explained in detail below.

Set an 8-bit instruction to (binary code): FXNNNNNN

F: "0" is the calling scene; "1" is the storage scene

X: 0

NNNNNN: Scene no. (0...63)

The parameter setting option is 1~64. In fact, the scene message received by the communication object "Scene" corresponds to 0~63. If scene 1 is set in the parameter, the communication object "Scene" should receive the scene message 0. As follows:

Object message value	Description
0	recall scene1
1	recall scene2
2	recall scene3
...	...
63	recall scene64
128	storage scene1
129	storage scene2
130	storage scene3
...	...
191	storage scene64

188	Forced output	Switch A-{{...}}	1bit 2bit	C,W	1.003 DPT_Enable 2.001 DPT_Switch control
------------	----------------------	-------------------------	----------------------------	------------	--

This communication object is enabled after the enforcement function is enabled.

In 1 bit, when the message value "1" is received, the enforcement mode is enabled. At this time, the device ignores other actions except for enforcement. When the message value "0" is received, the forced execution mode is ended, and the position of the contact at the time of forced operation is set by the parameter.

At 2bit, the contact is forcibly closed when the message value "3" is received; The contact is forcibly disconnected when the message value "2" is received; the enforcement mode is canceled when the message value "1" or "0" is received.

189	Logic 1	Switch A-{{...}}	1bit	C,W	1.002 DPT_Bool
------------	----------------	-------------------------	-------------	------------	-----------------------

This communication object is enabled when the parameter "enable" is selected in the parameter "The input 1 of logic" for the logic input of input1.

190	Logic 2	Switch A-{{...}}	1bit	C,W	1.002 DPT_Bool
This communication object is enabled when the parameter "enable" is selected in the parameter "The input 2 of logic" for the logic input of input2.					

Table5.2.2Communication object of"Switch X(X=A,B)"

5.2.3 Communication object of "Dimming CCT"

序号 ^	名称	对象功能	描述	群组地址	长度	C	R	W	T	U	数据类型	优先级
135	Dimming CCT-...	Switching			1 bit	C	-	W	-	-	switch	低
136	Dimming CCT-...	Relative dimming			4 bit	C	-	W	-	-	dimming control	低
137	Dimming CCT-...	Absolute dimming			1 byte	C	-	W	-	-	percentage (0..100%)	低
138	Dimming CCT-...	Switching, status			1 bit	C	R	-	T	-	switch	低
139	Dimming CCT-...	Brightness value, status			1 byte	C	R	-	T	-	percentage (0..100%)	低
140	Dimming CCT-...	Relative colour temperature control			4 bit	C	-	W	-	-	dimming control	低
141	Dimming CCT-...	Absolute colour temperature control			2 bytes	C	-	W	-	-	absolute colour temperature (K)	低
142	Dimming CCT-...	Colour temperature, status			2 bytes	C	R	-	T	-	absolute colour temperature (K)	低
143	Dimming CCT-...	Scene			1 byte	C	-	W	-	-	scene control	低
144	Dimming CCT-...	Forced operation			1 bit	C	-	W	-	-	switch	低
145	Dimming CCT-...	Sequence scene			1 byte	C	-	W	-	-	scene number	低
146	Dimming CCT-...	Start/stop sequence 1			1 bit	C	-	W	-	-	start/stop	低
147	Dimming CCT-...	Sequence 1, status			1 bit	C	R	-	T	-	start/stop	低
148	Dimming CCT-...	Start/stop sequence 2			1 bit	C	-	W	-	-	start/stop	低
149	Dimming CCT-...	Sequence 2, status			1 bit	C	R	-	T	-	start/stop	低
150	Dimming CCT-...	Start/stop sequence 3			1 bit	C	-	W	-	-	start/stop	低
151	Dimming CCT-...	Sequence 3, status			1 bit	C	R	-	T	-	start/stop	低
152	Dimming CCT-...	Start/stop sequence 4			1 bit	C	-	W	-	-	start/stop	低
153	Dimming CCT-...	Sequence 4, status			1 bit	C	R	-	T	-	start/stop	低

Fig.5.2.3Communication object of"Dimming CCT"

NO.	Object Function	Name	Data Type	Flag	DPT
135	Switching	Dimming CCT-{{...}}	1bit	C,W	1.001 switch
<p>The communication object is used to receive a command of switching on/off lamps. Telegrams:</p> <p>1——Switch on</p> <p>0——Switch off</p> <p>The name in parentheses changes with the parameter "Description (max 30char.)". If description is empty, display "Dimming CCT - ..." by default. The same below.</p>					
136	Relative dimming	Dimming CCT-{{...}}	4bit	C,W	3.007 dimming
<p>The communication object is used to receive a command of relative dimming, to dim up or dim down.</p> <p>Dimming down when telegram is 1~7, and the larger this range the adjust step is smaller. That is, the maximum step of dimming down when is 1, and the minimum step of dimming down when is 7, stop dimming when is 0;</p> <p>Dimming up when telegram is 9~15, and the larger this range the adjust step is smaller. That is, the maximum step of dimming up when is 9, and the minimum step of dimming up when is 15, stop dimming when is 8.</p> <p>The correspondence between the value of the relatively dimming telegram and brightness chance reference obj.55.</p>					
137	Absolute dimming	Dimming CCT-{{...}}	1byte	C,W	5.001 percentage
<p>The communication object is used to receive a command of absolute dimming.</p>					

Telegrams: 0...100%																																									
138	Switching, status	Dimming CCT-{{...}}	1bit	C,R, T	1.001 switch																																				
<p>The communication object is used to report the status of the current switch to the bus. Send "1" to the bus when the value of the brightness is larger than 0, send "0" to the bus with value of "0".</p> <p>Send the status when voltage recovery.</p>																																									
139	Brightness value, status	Dimming CCT-{{...}}	1byte	C,R, T	5.001 percentage																																				
<p>The communication object is used to report the status of the current brightness value to the bus.</p> <p>Send the status when voltage recovery.</p>																																									
140	Relative colour temperature control	Dimming CCT-{{...}}	4bit	C,W	3.007 dimming																																				
<p>The communication object is used to receive a command of relative colour temperature control, the new colour temperature=current colour temperature±(maximum physical colour temperature - minimum. physical colour temperature)*adjustment percentage .For example, the maximum physical colour temperature is 7000K, the minimum physical colour temperature is 2000K, the current colour temperature value is 3000K, and the decrease the colour temperature 50%, the new color temperature value is 5500K.</p> <p>Note:Output as minimum value when the new colour temperature value is lower than the set minimum, and output as maximum value when it is higher than the set maximum.</p> <p>The correspondence between the value of the relatively dimming telegram and colour temperature chance is as follows:</p> <table border="1" data-bbox="164 1346 1422 1744"> <thead> <tr> <th>Telegram value</th> <th>0</th> <th>1</th> <th>2</th> <th>3</th> <th>4</th> <th>5</th> <th>6</th> <th>7</th> </tr> </thead> <tbody> <tr> <td>Decrease the colour temperature value</td> <td>stop</td> <td>(100%)</td> <td>(50%)</td> <td>(25%)</td> <td>(12%)</td> <td>(6%)</td> <td>(3%)</td> <td>(1%)</td> </tr> <tr> <th>Telegram value</th> <th>8</th> <th>9</th> <th>10</th> <th>11</th> <th>12</th> <th>13</th> <th>14</th> <th>15</th> </tr> <tr> <td>Increase the colour temperature value</td> <td>stop</td> <td>(100%)</td> <td>(50%)</td> <td>(25%)</td> <td>(12%)</td> <td>(6%)</td> <td>(3%)</td> <td>(1%)</td> </tr> </tbody> </table>						Telegram value	0	1	2	3	4	5	6	7	Decrease the colour temperature value	stop	(100%)	(50%)	(25%)	(12%)	(6%)	(3%)	(1%)	Telegram value	8	9	10	11	12	13	14	15	Increase the colour temperature value	stop	(100%)	(50%)	(25%)	(12%)	(6%)	(3%)	(1%)
Telegram value	0	1	2	3	4	5	6	7																																	
Decrease the colour temperature value	stop	(100%)	(50%)	(25%)	(12%)	(6%)	(3%)	(1%)																																	
Telegram value	8	9	10	11	12	13	14	15																																	
Increase the colour temperature value	stop	(100%)	(50%)	(25%)	(12%)	(6%)	(3%)	(1%)																																	
141	Absolute colour temperature control	Dimming CCT-{{...}}	2byte	C,W	7.600 Absolute colour temperature																																				
<p>The communication object is used to receive a command of absolute colour temperature control, Telegrams: 2000...7000K</p>																																									
142	Colour temperature, status	Dimming CCT-{{...}}	2byte	C,R, T	7.600 Absolute colour temperature																																				

The communication object is used to report the status of the current colour temperature value to the bus.

Send the status when voltage recovery.

143	Scene	Dimming CCT-{{...}}	1byte	C,W	18.001 scene control
------------	--------------	----------------------------	--------------	------------	-----------------------------

The communication object is used to receive a 8 bit command to recall or storage scene. Detailed 8bit the meaning of the directive.

Set up a 8bit Orders for the (Binary code): FXNNNNNN

F: '0' recall scene; '1' for storage scene;

X : 0 ;

NNNNNN: Scene number(0... 63).

As follows:

Object message value	Description
0	Recall scene 1
1	Recall scene 2
2	Recall scene 3
...	...
63	Recall scene 64
128	Store scene 1
129	Store scene 2
130	Store scene 3
...	...
191	Store scene 64

Parameter setting Options are 1~64, actually communication object "Scene" corresponds to the telegram received is 0~63. Such as parameter settings is the scene 1, communication object "Scene" sends the scene for 0.

144	Forced operation	Dimming CCT-{{...}}	1bit 2bit	C,W	1.003 enable 2.001 DPT_Switch control
------------	-------------------------	----------------------------	----------------------	------------	--

The communication object is used to trigger a forced operation. Save the trigger status when voltage failure, and keep the status at voltage recovery.

When 1bit, activate the forced operation when receive telegram 1, at this time, ignore all the other actions; End the forced operation when receive telegram 0, and the behaviour in forced operation is defined by parameter.

When 2bit, force to switch off when receive telegram 3; force to switch on when receive telegram 2; End the forced operation when receive telegram 1 or 0.

Note: The end telegram is invalid when the forced operation is not active, and ignore it directly.					
145	Sequence scene	Dimming CCT-{{...}}	1byte	C,W	17.001 scene number
The communication object recall the sequence function through a scene number.					
146/ 148/ 150/ 152	Start/stop sequence 1 Start/stop sequence 2 Start/stop sequence 3 Start/stop sequence 4	Dimming CCT-{{...}}	1bit	C,W	1.010 start/stop
The communication object is used to control the start/stop sequences. Telegram: 1: Start 0: Stop					
147/ 149/ 151/ 153	Sequence 1, status Sequence 2, status Sequence 3, status Sequence 4, status	Dimming CCT-{{...}}	1bit	C,R, T	1.010 start/stop
The communication object is used to send the sequences status. Telegram: 1: Start 0: Stop Note: The brightness status during sequence execution sends the brightness status when the target brightness value is reached at each step of the sequence, and only sends when the brightness changes.					

Table5.2.3Communication object of "Dimming CCT"

5.2.4 Communication object of "Dimming RGB"

序号 ^	名称	对象功能	描述	群组地址	长度	C	R	W	T	U	数据类型	优先级
154	Dimming RGB-...	Switching			1 bit	C	-	W	-	-	switch	低
156	Dimming RGB-...	RGB dimming value			3 bytes	C	-	W	-	-	RGB value 3x(0..255)	低
157	Dimming RGB-...	Switching, status			1 bit	C	R	-	T	-	switch	低
158	Dimming RGB-...	RGB Brightness value, status			3 bytes	C	R	-	T	-	RGB value 3x(0..255)	低
171	Dimming RGB-...	Scene			1 byte	C	-	W	-	-	scene control	低
172	Dimming RGB-...	Forced operation			1 bit	C	-	W	-	-	switch	低
173	Dimming RGB-...	Sequence scene			1 byte	C	-	W	-	-	scene number	低
174	Dimming RGB-...	Start/stop sequence 1			1 bit	C	-	W	-	-	start/stop	低
175	Dimming RGB-...	Sequence 1, status			1 bit	C	R	-	T	-	start/stop	低
176	Dimming RGB-...	Start/stop sequence 2			1 bit	C	-	W	-	-	start/stop	低
177	Dimming RGB-...	Sequence 2, status			1 bit	C	R	-	T	-	start/stop	低
178	Dimming RGB-...	Start/stop sequence 3			1 bit	C	-	W	-	-	start/stop	低
179	Dimming RGB-...	Sequence 3, status			1 bit	C	R	-	T	-	start/stop	低
180	Dimming RGB-...	Start/stop sequence 4			1 bit	C	-	W	-	-	start/stop	低
181	Dimming RGB-...	Sequence 4, status			1 bit	C	R	-	T	-	start/stop	低

组合控制

序号 ^	名称	对象功能	描述	群组地址	长度	C	R	W	T	U	数据类型	优先级
157	Dimming RGB-...	Switching, status			1 bit	C	R	-	T	-	switch	低
159	Dimming RGB-...	R Switching			1 bit	C	-	W	-	-	switch	低
160	Dimming RGB-...	G Switching			1 bit	C	-	W	-	-	switch	低
161	Dimming RGB-...	B Switching			1 bit	C	-	W	-	-	switch	低
162	Dimming RGB-...	R Relative dimming			4 bit	C	-	W	-	-	dimming control	低
163	Dimming RGB-...	G Relative dimming			4 bit	C	-	W	-	-	dimming control	低
164	Dimming RGB-...	B Relative dimming			4 bit	C	-	W	-	-	dimming control	低
165	Dimming RGB-...	R Absolute dimming			1 byte	C	-	W	-	-	percentage (0..100%)	低
166	Dimming RGB-...	G Absolute dimming			1 byte	C	-	W	-	-	percentage (0..100%)	低
167	Dimming RGB-...	B Absolute dimming			1 byte	C	-	W	-	-	percentage (0..100%)	低
168	Dimming RGB-...	R Brightness value, status			1 byte	C	R	-	T	-	percentage (0..100%)	低
169	Dimming RGB-...	G Brightness value, status			1 byte	C	R	-	T	-	percentage (0..100%)	低
170	Dimming RGB-...	B Brightness value, status			1 byte	C	R	-	T	-	percentage (0..100%)	低
171	Dimming RGB-...	Scene			1 byte	C	-	W	-	-	scene control	低
172	Dimming RGB-...	Forced operation			1 bit	C	-	W	-	-	switch	低
173	Dimming RGB-...	Sequence scene			1 byte	C	-	W	-	-	scene number	低
174	Dimming RGB-...	Start/stop sequence 1			1 bit	C	-	W	-	-	start/stop	低
175	Dimming RGB-...	Sequence 1, status			1 bit	C	R	-	T	-	start/stop	低
176	Dimming RGB-...	Start/stop sequence 2			1 bit	C	-	W	-	-	start/stop	低
177	Dimming RGB-...	Sequence 2, status			1 bit	C	R	-	T	-	start/stop	低
178	Dimming RGB-...	Start/stop sequence 3			1 bit	C	-	W	-	-	start/stop	低
179	Dimming RGB-...	Sequence 3, status			1 bit	C	R	-	T	-	start/stop	低
180	Dimming RGB-...	Start/stop sequence 4			1 bit	C	-	W	-	-	start/stop	低
181	Dimming RGB-...	Sequence 4, status			1 bit	C	R	-	T	-	start/stop	低

独立控制

Fig.5.2.4Communication object of"Dimming RGB"

NO.	Object Function	Name	Data Type	Flag	DPT
154	Switching	Dimming RGB-{{...}}	1bit	C,W	1.001 switch
<p>This communication object is visible when "combined control" selected for RGB control type. The communication object is used to receive a command of switching on/off lamps. Telegrams:</p> <p>1——Switch on</p> <p>0——Switch off</p> <p>The name in parentheses changes with the parameter "Description (max 30char.)". If description is empty, display "Dimming RGB - ..." by default. The same below.</p>					
156	RGB dimming value	Dimming RGB-{{...}}	3byte	C,W	232.600 RGB value 3x(0..255)
<p>This communication object is visible when "combined control" selected for RGB control type. The communication object is used to receive a command of absolute dimming. Telegrams: 0...255</p>					

157	Switching, status	Dimming RGB-{{...}}	1bit	C,R,T	1.001 switch
<p>The communication object is used to report the status of the current switch to the bus. Send "1" to the bus when the value of the brightness is larger than 0, send "0" to the bus with value of "0".</p> <p>Send the status when voltage recovery.</p>					
158	RGB Brightness value, status	Dimming RGB-{{...}}	3byte	C,R,T	232.600 RGB value 3x(0..255)
<p>This communication object is visible when "combined control" selected for RGB control type. The communication object is used to report the status of the current RGB brightness to the bus.</p> <p>Send the status when voltage recovery.</p>					
159/ 160/ 161	R Switching G Switching B Switching	Dimming RGB-{{...}}	1bit	C,W	1.001 switch
<p>This communication object is visible when "individual control" selected for RGB control type.</p> <p>Obj.159: Used to receive a command of R switching on/off lamps.</p> <p>Obj.160: Used to receive a command of G switching on/off lamps.</p> <p>Obj.161: Used to receive a command of B switching on/off lamps.</p> <p>Telegrams:</p> <p>1——Switch on</p> <p>0——Switch off</p>					
162/ 163/ 164	R Relative dimming G Relative dimming B Relative dimming	Dimming RGB-{{...}}	4bit	C,W	3.007 dimming
<p>This communication object is visible when "individual control" selected for RGB control type.</p> <p>The communication object is used to receive a command of relative dimming, to dim up or dim down.</p> <p>Dimming down when telegram is 1~7, and the larger this range the adjust step is smaller. That is, the maximum step of dimming down when is 1, and the minimum step of dimming down when is 7, stop dimming when is 0.</p> <p>Dimming up when telegram is 9~15, and the larger this range the adjust step is smaller. That is, the maximum step of dimming up when is 9, and the minimum step of dimming up when is 15, stop dimming when is 8.</p> <p>Obj.162: Used to receive a command of R relative dimming.</p> <p>Obj.163: Used to receive a command of G relative dimming.</p>					

Obj.164: Used to receive a command of B relative dimming.																	
165/ 166/ 167	R Absolute dimming G Absolute dimming B Absolute dimming	Dimming RGB-{{...}}	1byte	C,W	5.001 percentage												
<p>This communication object is visible when "individual control" selected for RGB control type. Telegrams:0...100%</p> <p>Obj.165: Used to receive a command of R absolute dimming. Obj.166: Used to receive a command of G absolute dimming. Obj.167: Used to receive a command of B absolute dimming.</p>																	
168/ 169/ 170	R Brightness value, status G Brightness value, status B Brightness value, status	Dimming RGB-{{...}}	1byte	C,R,T	5.001 percentage												
<p>This communication object is visible when "individual control" selected for RGB control type. Send the status at power-up when voltage recovery.</p> <p>Obj.168: Used to report the status of the current R brightness value to the bus. Obj.169: Used to report the status of the current G brightness value to the bus. Obj.170: Used to report the status of the current B brightness value to the bus.</p>																	
171	Scene	Dimming RGB-{{...}}	1byte	C,W	18.001 scene control												
<p>The communication object is used to receive a 8 bit command to recall or storage scene. Detailed 8bit the meaning of the directive.</p> <p>Set up a 8bit Orders for the (Binary code): FXNNNNNN</p> <p style="padding-left: 40px;">F: '0' recall scene; '1' for storage scene X : 0 NNNNNN: Scene number(0... 63)</p> <p>As follows:</p> <table border="1" style="margin-left: auto; margin-right: auto;"> <thead> <tr> <th>Object message value</th> <th>Description</th> </tr> </thead> <tbody> <tr> <td>0</td> <td>Recall scene 1</td> </tr> <tr> <td>1</td> <td>Recall scene 2</td> </tr> <tr> <td>2</td> <td>Recall scene 3</td> </tr> <tr> <td>...</td> <td>...</td> </tr> <tr> <td>63</td> <td>Recall scene 64</td> </tr> </tbody> </table>						Object message value	Description	0	Recall scene 1	1	Recall scene 2	2	Recall scene 3	63	Recall scene 64
Object message value	Description																
0	Recall scene 1																
1	Recall scene 2																
2	Recall scene 3																
...	...																
63	Recall scene 64																

128	Store scene 1
129	Store scene 2
130	Store scene 3
...	...
191	Store scene 64

Parameter setting Options are 1~64, actually communication object "Scene" corresponds to the telegram received is 0~63. Such as parameter settings is the scene 1, communication object "Scene" sends the scene for 0.

172	Forced operation	Dimming RGB-{{...}}	1bit 2bit	C,W	1.003 enable 2.001 DPT_Switch control
------------	-------------------------	--------------------------------	----------------------	------------	--

The communication object is used to trigger a forced operation. Save the trigger status when voltage failure, and keep the status at voltage recovery.

When 1bit, activate the forced operation when receive telegram 1, at this time, ignore all the other actions; End the forced operation when receive telegram 0, and the behaviour in forced operation is defined by parameter.

When 2bit, force to switch off when receive telegram 3; force to switch on when receive telegram 2; End the forced operation when receive telegram 1 or 0.

Note: The end telegram is invalid when the forced operation is not active, and ignore it directly.

173	Sequence scene	Dimming RGB-{{...}}	1byte	C,W	17.001 scene number
------------	-----------------------	--------------------------------	--------------	------------	----------------------------

The communication object recall the sequence function through a scene number.

174/ 176/ 178/ 180	Start/stop sequence 1 Start/stop sequence 2 Start/stop sequence 3 Start/stop sequence 4	Dimming RGB-{{...}}	1bit	C,W	1.010 start/stop
---------------------------------------	--	--------------------------------	-------------	------------	-------------------------

The communication object is used to control the start/stop sequences. Telegram:

1: Start

0: Stop

175/ 177/ 179/ 181	Sequence 1, status Sequence 2, status Sequence 3, status Sequence 4, status	Dimming RGB-{{...}}	1bit	C,R,T	1.010 start/stop
---------------------------------------	--	--------------------------------	-------------	--------------	-------------------------

The communication object is used to send the sequences status. Telegram:

1: Start

0: Stop

Note: The brightness status during sequence execution sends the brightness status when the target brightness value is reached at each step of the sequence, and only sends when the brightness changes.

Table 5.2.4 Communication object of "Dimming RGB"

5.3 Communication object of "UI setting"

5.3.1 Communication object of "Input X(X=1~8)"

序号 ^	名称	对象功能	描述	群组地址	长度	C	R	W	T	U	数据类型	优先级
6	Input 1-...	Switch			1 bit	C	-	W	T	U	switch	低
10	Input 1-...	Disable			1 bit	C	-	W	-	-	enable	低

序号 ^	名称	对象功能	描述	群组地址	长度	C	R	W	T	U	数据类型	优先级
6	Input 1-...	Press, Switch			1 bit	C	-	W	T	U	switch	低
7	Input 1-...	Release, Switch			1 bit	C	-	W	T	U	switch	低
10	Input 1-...	Disable			1 bit	C	-	W	-	-	enable	低

序号 ^	名称	对象功能	描述	群组地址	长度	C	R	W	T	U	数据类型	优先级
6	Input 1-...	Short, Switch			1 bit	C	-	W	T	U	switch	低
7	Input 1-...	Long, Switch			1 bit	C	-	W	T	U	switch	低
10	Input 1-...	Disable			1 bit	C	-	W	-	-	enable	低

Switch

序号 ^	名称	对象功能	描述	群组地址	长度	C	R	W	T	U	数据类型	优先级
6	Input 1-...	Short, Switch			1 bit	C	-	W	T	U	switch	低
7	Input 1-...	Long, Dimming			4 bit	C	-	W	T	-	dimming control	低
10	Input 1-...	Disable			1 bit	C	-	W	-	-	enable	低

Dimming

序号 ^	名称	对象功能	描述	群组地址	长度	C	R	W	T	U	数据类型	优先级
6	Input 1-...	Press, 1bit value			1 bit	C	-	-	T	-	switch	低
7	Input 1-...	Release, 1bit value			1 bit	C	-	-	T	-	switch	低
10	Input 1-...	Disable			1 bit	C	-	W	-	-	enable	低

序号 ^	名称	对象功能	描述	群组地址	长度	C	R	W	T	U	数据类型	优先级
6	Input 1-...	Short, 1bit value			1 bit	C	-	-	T	-	switch	低
7	Input 1-...	Long, 1bit value			1 bit	C	-	-	T	-	switch	低
10	Input 1-...	Disable			1 bit	C	-	W	-	-	enable	低

Value output

序号 ^	名称	对象功能	描述	群组地址	长度	C	R	W	T	U	数据类型	优先级
6	Input 1-...	Scene			1 byte	C	-	-	T	-	scene control	低
10	Input 1-...	Disable			1 bit	C	-	W	-	-	enable	低

序号 ^	名称	对象功能	描述	群组地址	长度	C	R	W	T	U	数据类型	优先级
6	Input 1-...	Press, Scene			1 byte	C	-	-	T	-	scene control	低
7	Input 1-...	Release, Scene			1 byte	C	-	-	T	-	scene control	低
10	Input 1-...	Disable			1 bit	C	-	W	-	-	enable	低

序号 ^	名称	对象功能	描述	群组地址	长度	C	R	W	T	U	数据类型	优先级
6	Input 1-...	Short, Scene			1 byte	C	-	-	T	-	scene control	低
7	Input 1-...	Long, Scene			1 byte	C	-	-	T	-	scene control	低
10	Input 1-...	Disable			1 bit	C	-	W	-	-	enable	低

Scene control

序号 ^	名称	对象功能	描述	群组地址	长度	C	R	W	T	U	数据类型	优先级
6	Input 1-...	Up/Down, Blind			1 bit	C	-	W	T	-	up/down	低
7	Input 1-...	Stop/Adjust, Blind			1 bit	C	-	W	T	-	step	低
10	Input 1-...	Disable			1 bit	C	-	W	-	-	enable	低

Blind

序号 ^	名称	对象功能	描述	群组地址	长度	C	R	W	T	U	数据类型	优先级
6	Input 1-...	Register value			1 byte	C	-	W	T	-	scene number	低
10	Input 1-...	Disable			1 bit	C	-	W	-	-	enable	低

Shift register

序号 ^	名称	对象功能	描述	群组地址	长度	C	R	W	T	U	数据类型	优先级
6	Input 1-...	Object1-On/Off			1 bit	C	-	W	T	-	switch	低
7	Input 1-...	Object2-Up/Down			1 bit	C	-	W	T	-	up/down	低
8	Input 1-...	Object3-SceneControl			1 byte	C	-	-	T	-	scene control	低
9	Input 1-...	Object4-SceneControl			1 byte	C	-	-	T	-	scene control	低
10	Input 1-...	Disable			1 bit	C	-	W	-	-	enable	低

Multiple operation

序号 ^	名称	对象功能	描述	群组地址	长度	C	R	W	T	U	数据类型	优先级
6	Input 1-...	Press, Delay mode			1 bit	C	-	-	T	-	switch	低
10	Input 1-...	Disable			1 bit	C	-	W	-	-	enable	低

序号 ^	名称	对象功能	描述	群组地址	长度	C	R	W	T	U	数据类型	优先级
6	Input 1-...	Short, Delay mode			1 byte	C	-	-	T	-	counter pulses (0..255)	低
7	Input 1-...	Long, Delay mode			1 bit	C	-	-	T	-	switch	低
10	Input 1-...	Disable			1 bit	C	-	W	-	-	enable	低

Delay mode

Fig.5.3.1 "Input x"(x=1-8)Communication object of

NO.	功能	Name	Data Type	Flag	DPT
6	Switch	Input X-{{...}}	1bit	C,W, T,U	1.001 DPT_Switch
6	Press, Switch	Input X-{{...}}	1bit	C,W, T,U	1.001 DPT_Switch
6	Short, Switch	Input X-{{...}}	1bit	C,W, T,U	1.001 DPT_Switch
7	Release, Switch	Input X-{{...}}	1bit	C,W, T,U	1.001 DPT_Switch
7	Long, Switch	Input X-{{...}}	1bit	C,W, T,U	1.001 DPT_Switch

These communication objects are used to trigger a switching operation. Use a common object or two separate objects is according to the parameter setting when press/release and long/short operation.

Only the object "Switch" is visible when use a common object. If use two separate objects, "press/release" is visible when there is no distinction for short/long operation; "Short/Long" is visible when there is distinction for short/long operation. Telegrams:

0 — Off

1 — On

After the bus recovery or programming, the default value is "0".

The name in parentheses changes with the parameter "Description (max 30char.)". If description is empty, display "Input x - ..." by default. The same below.

6	Short, Switch	Input X-{{...}}	1bit	C,W, T,U	1.001 DPT_Switch
7	Long, Dimming	Input X-{{...}}	4bit	C,W,T	3.007 DPT_Dimming control

These two communication objects are used to switch/dimming operation, with distinction for long/short operation.

Obj.6: Used to trigger switch operation. Telegrams:

0—OFF

1—ON

After the bus recovery or programming, the default value is "0".

Obj.7: Used to trigger a relative dimming operation.

Dimming down when telegram is 1~7, and the larger this range the adjust step is smaller. That is, the maximum step of dimming down when is 1, and the minimum step of dimming down when is 7, stop dimming when is 0;

Dimming up when telegram is 9~15, and the larger this range the adjust step is smaller. That is, the maximum step of dimming up when is 9, and the minimum step of dimming up when is 15, stop dimming when is 8.

After the bus recovery or programming, the default value is "0".

6	Press, 1bit/.../2byte value	Input X-{{...}}	1bit	C,T	1.001 DPT_Switch 2.001 DPT_Switch control 3.007 DPT_Dimming control 5.010 DPT_counter pulses 7.001 DPT_pulses
6	Short, 1bit/.../2byte value	Input X-{{...}}	2bit 4bit	C,T	
7	Release, 1bit/.../2byte value	Input X-{{...}}	1byte 2byte	C,T	
7	Long, 1bit/.../2byte value	Input X-{{...}}		C,T	

These two communication objects are used for sending a fixed value to the bus, "press/release" is visible when there is no distinction for short/long operation; "short/long" is visible when there is distinction for short/long operation. Range of values that can be sent are determined by the datatype, and the datatype is determined by the parameter setting.

6	Scene	Input X-{{...}}	1byte	C,T	18.001 DPT_SceneControl
----------	--------------	------------------------	--------------	------------	--------------------------------

6	Press, Scene	Input X-{{...}}	1byte	C,T	18.001 DPT_SceneControl
6	Short, Scene	Input X-{{...}}	1byte	C,T	18.001 DPT_SceneControl
7	Release, Scene	Input X-{{...}}	1byte	C,T	18.001 DPT_SceneControl
7	Long, Scene	Input X-{{...}}	1byte	C,T	18.001 DPT_SceneControl

These communication objects are used to send a 8 bit command to recall or storage scene. Use a common object or two separate objects is according to the parameter setting when press/release and long/short operation.

Only the object "Scene" is visible when use a common object. If use two separate objects, "press/release" is visible when there is no distinction for short/long operation; "Short/Long" is visible when there is distinction for short/long operation.

Detailed 8bit the meaning of the directive.

Set up a 8bit Orders for the (Binary code): FXNNNNNN

F: '0' recall scene; '1' for storage scene;

X : 0 ;

NNNNNN: Scene number(0... 63).

As follows:

Object message value	Description
0	Recall scene 1
1	Recall scene 2
2	Recall scene 3
...	...
63	Recall scene 64
128	Store scene 1
129	Store scene 2
130	Store scene 3
...	...
191	Store scene 64

Parameter setting Options are 1~64, actually communication object "Scene" corresponds to the telegram received is 0~63. Such as parameter settings is the scene 1,communication object "Scene" sends the scene for 0.

6	Up/Down, Blind	Input X-{{...}}	1bit	C,W,T	1.008 DPT_up/down
7	Stop/Adjust, Blind	Input X-{{...}}	1bit	C,W,T	1.007 DPT_Step

These two communication objects are used to control the blind up,down, stop:

Obj.6: Used for sending the telegram to the bus, to control blind up/down. Telegrams:

<p>1—Move down</p> <p>0—Move up</p> <p>After the bus recovery or programming, the default value is "0".</p> <p>Obj.7: Used for sending the telegram to the bus, to stop curtain movement. Telegrams:</p> <p>1—Stop blind move down</p> <p>0—Stop blind move up</p> <p>After the bus recovery or programming, the default value is "0".</p>					
6	Register value	Input X-{{...}}	1byte	C,W,T	5.010 counter pulses 17.001 scene number 20.102 HVAC mode
<p>The communication object is used to send the value of shift register. Range of values that can be sent are determined by the datatype, and the datatype is determined by the parameter setting.</p>					
6/ 7/ 8/ 9	Object x-On/Off Object x-Up/Down Object x-SceneControl Object x-Percentage Object x-Unsigned value	Input X-{{...}}	1bit 1bit 1byte 1byte 1byte	C,W,T C,W,T C,T C,T C,T	1.001 DPT_Switch 1.008 DPT_up/down 18.001 DPT_SceneControl 5.001 DPT_Scaling 5.010 DPT_counter pulses
<p>These communication objects are objects of multiple operation, up to activate 4 objects at the same time, and operate once can send 4 different values to the bus via these objects. Range of values that can be sent are determined by the datatype, and the datatype is determined by the parameter setting.</p> <p>After the bus recovery or programming, the default value for "On/Off" and "Up/Down" is "0".</p>					
6	Press, Delay mode	Input X-{{...}}	1bit	C,T	1.001 DPT_Switch
6	Short, Delay mode	Input X-{{...}}	4bit	C,T	3.007 DPT_Dimming control
7	Long, Delay mode	Input X-{{...}}	1byte	C,T	5.010 DPT_counter pulses
<p>These two communication objects are used to send the value of delay mode to the bus, "press" is visible when there is no distinction for short/long operation; "Short/Long" is visible when there is distinction for short/long operation. Range of values that can be sent are determined by the datatype, and the datatype is determined by the parameter setting.</p>					
10	Disable	Input X-{{...}}	1bit	C,W	1.003 DPT_enable
<p>The communication object is used to disable/enable the function of contact input, the telegram value is decided by the parameter.</p>					

Table5.3.1 Communication object of "Input x"(x=1~8)

5.3.2 Communication object of "LED X(X=5~8)"

序号 ^	名称	对象功能	描述	群组地址	长度	C	R	W	T	U	数据类型	优先级
50	LED 5-...	Status			1 bit	C	-	W	T	U	switch	低
50	LED 5-...	Status			1 byte	C	-	W	T	U	counter pulses (0..255)	低

Fig.5.3.2 "LED x"(x=5~8)Communication object of

NO.	Object Function	Name	Data Type	Flag	DPT
50...53	Status	LED X-{{...}}	1bit 1byte	C,W,T,U	1.001 DPT_Switch 5.010 DPT_counter pulses
<p>The communication object is used to receive the telegrams of 1bit/1byte, LED indicates according to the telegrams and parameter setting.</p> <p>The name in parentheses changes with the parameter "Description (max 30char.)". If description is empty, display "LED X-..." by default.</p>					

Table5.3.2 Communication object of"LED x"