

# User manual

## **Homira KNX General Dimming Actuator, 2/4-Fold**

**HM-DI-02.3**

**HM-DI-04.3**

**KNX/EIB Home and Building Control System**

# Attentions

1. Please keep devices away from strong magnetic field, high temperature, wet environment;



2. Do not fall the device to the ground or make them get hard impact;



3. Do not use wet cloth or volatile reagent to wipe the device;



4. Do not disassemble the devices.

 When using this product, please pay attention to analysis of the following troubleshooting.

| NO. | Exception  | Possible cause   | Solution  | Remark  |
|-----|--|--|---|---|
| 1   | Lamp flickers in the low brightness  | Lamp driver works unstably at low voltage                                      | Increase the min. brightness appropriately to debounce  |   |
|     |  |  | Use the user defined curve, and set the output value when 1% as the min. brightness that can be stable        |   |
| 2   | There is no obvious differences for LED in the high brightness             | The LED has reached the highest brightness after a certain voltage             | Decrease the max. brightness appropriately to avoid the invalid control                                       |   |
|     |  |  | Use the user defined curve, and set the output value when 100% as the control value of LED highest brightness |   |
| 3   | Flicker or unstable when LED startup                                       | Lamp driver needs an extra startup voltage for stable output                   | Enable the additional startup characteristic and set its parameter, to avoid the flicker when startup         |   |
| 4   | The min. control value when lamp off is higher than the value when lamp on | Lamp driver needs an extra startup voltage for lamp on normally                | Enable the additional startup characteristic and set its parameter, to improved dimming effect                |   |
| 5   | Lamp flickers in dimming   | Lamp dose not support dimming  | Check the lamp characteristic supports dimming or not   | If there is no improvement, it is suggested to replace the lamp or driver |
|     |  | Incompatible between lamp and driver power supply                              | Check the lamp is matched to the driver or not  |   |
|     |  | Incompatible of load type or dimming curve                                     | Adjust the ETS parameter and check again  |   |
|     |  | Brightness changed in dimming is too fast                                      | Extend the dimming time and change the dimming curve  |   |
|     |  | Incompatible of dimming curve if only flicker in a partial curve in the middle | Use the user defined curve to adjust the flickering curve   |   |
|     |  | If only flicker in the high brightness   | Decrease the max. brightness value  |   |

| NO.                 | Exception   | Possible cause   | Solution  | Remark  |
|---------------------|---|--|---|---|
| 5                   | Lamp flickers in dimming  | Lamp driver is not good enough, unstable voltage, compatibility issue                | Test with an additional incandescent lamp or electronic dummy load in parallel  | If there is no improvement, it is suggested to replace the lamp or driver   |
| 6                   | The dimmable range is not 0-100%, not a good experience with user operation | It is the limitation of the operation voltage range and effect of lamp driver        | Use the user defined curve, and set the output value when 1% as the min. brightness, set the output value when 100% as the control value of lamp highest brightness |   |
| 7                   | Lamp is still brighter at lower brightness, and have a small dimmable range | Incompatible of dimming curve  | Change the curve to one with a lower change value, such as quadratic, cubic, exponential, logarithmic, even use the user defined curve                              |   |
|                     |   | Possible the min. brightness is high   | Check and decrease the min. brightness  |   |
| 8                   | Switch off abnormally or can not turn on                                    | Operation voltage failure  | Check and reconnect   | Configure the monitoring the group addresses of abnormal status objects, re-check to confirm there is an alarm telegram or not, if still exist alarm and improve again according the alarm telegram |
|                     |   | The connected lamp has been overloaded and caused the protection of over-temperature | Reduce the load power   |   |
|                     |   | Output terminal is short-circuit and trigger the protection                          | Reconnect the wiring and test that there are no problems before power up again  |   |
|                     |   | The inrush current of lamp driver is too big and trigger the protection of over-load | Reduce the load power   |   |
|                     |   |  | Change to trailing edge<br>Change a better lamp or driver   |   |
| Bus voltage failure | Bus diagnostics and confirm to connect normally                             |  |   |   |
| 9                   | LED can not turn off  | Incompatible between lamp driver and dimmer  | Test with an additional incandescent lamp or electronic dummy load in parallel  | If there is no improvement, it is suggested to replace the LED or driver  |
|                     |   |  | Connect an external switch actuator channel with output in series, linking the switch object together to work simultaneously  |   |
|                     |   |  | Change a better LED or driver   |   |

# Contents

|  |    |
|--|----|
| Chapter 1 Summary .....                                    | 1  |
| Chapter 2 Technical Data.....                              | 3  |
| 2.1. Load type .....                                       | 5  |
| 2.2. Operation mode .....                                  | 8  |
| Chapter 3 Dimension and Connection Diagram.....            | 9  |
| 3.1. Dimension drawing .....                               | 9  |
| 3.2. Connection Diagram .....                              | 10 |
| Chapter 4 Project Design and Programming.....              | 11 |
| Chapter 5 Parameter setting description in the ETS .....   | 13 |
| 5.1. KNX Secure .....                                      | 13 |
| 5.2. Parameter window "General" .....                      | 17 |
| 5.3. Parameter window "Output setting" .....               | 20 |
| 5.3.1. Parameter window "Channel" .....                    | 22 |
| 5.3.2. Parameter window "User defined dimming curve" ..... | 32 |
| 5.3.3. Parameter window "Extension function" .....         | 34 |
| 5.4. Parameter window "Logic" .....                        | 49 |
| 5.4.1. Parameter window "AND/OR/XOR" .....                 | 50 |
| 5.4.2. Parameter window "Gate forwarding" .....            | 52 |
| 5.4.3. Parameter window "Threshold comparator" .....       | 54 |
| 5.4.4. Parameter window "Format convert" .....             | 56 |
| 5.4.5. Parameter window "Gate function" .....              | 57 |
| 5.4.6. Parameter window "Delay function" .....             | 59 |
| 5.4.7. Parameter window "Staircase lighting" .....         | 60 |
| Chapter 6 Description of Communication Object.....         | 62 |
| 6.1. "General" Communication Object .....                  | 62 |
| 6.2. "Output setting" Communication Object .....           | 63 |
| 6.3. "Logic" Communication Object.....                     | 68 |
| 6.3.1. "AND/OR/XOR" Communication Object .....             | 68 |
| 6.3.2. "Gate forwarding" Communication Object .....        | 69 |
| 6.3.3. "Threshold comparator" Communication Object .....   | 70 |
| 6.3.4. "Format convert" Communication Object .....         | 70 |
| 6.3.5. "Gate function" Communication Object .....          | 73 |
| 6.3.6. "Delay function" Communication Object .....         | 74 |
| 6.3.7. "Staircase lighting" Communication Object.....      | 75 |

### Chapter 1 Summary

KNX General Dimming Actuator, 1/2/4-Fold (hereinafter referred to as Dimmer) has 1/2/ 4 output channels, and it can connect with dimmable lamps (such as incandescent lamps, halogen lamps, energy-saving lamps, LED, etc.), and you can dim, preset scene, switch these lamps or other operations via the bus. In addition, as well as KNX Data Secure.

This dimmer is a modular installation device for fast installation in the distribution board on 35 mm mounting rails to DIN EN 60 715, the output adopts screw terminal to realize electrical connection. Bus connection is directly connected via KNX terminal, the additional power supply is not required except KNX bus.

You can build the various scenes with the dimmer, such as watch movie, entertainment, dinner and rest, and so on; its brightness value can be set as any value (1-100%); it is able to set the duration time to dim up or down to the target brightness and the gradual speed to extend the luminaries life and save energy.

The physical address assignment and parameter settings can be used with the engineering tool software ETS (version ETS5 or above) with the .knxprod file.

In use you need to note **the type of connected electrical load, thus reasonable select them and note their technical performance. If the technical performance of the selected load is not consistent with the technical performance of the dimmer, it is possible to affect the dimming effect.**

The manual provides detailed technical information about the dimmer, including installation and programming details, and explains how to use the dimmer in conjunction with examples in actual use.

The functions are summarized as followed:

- Switch, Relative dimming/Absolute dimming
- Status feedback of switch, brightness, as well as abnormal status (short-circuit, over-voltage, over-temperature and operating voltage failure)
- Reset behaviour after download/bus failure/bus recovery
- 6 dimming curves, including Linear, Exponential, Cubic, Quadratic, Logarithmic, Root and User defined curves
- Leading edge/Trailing edge phase cut dimming
- Manual operation and Output indication function
- Central control function (Only apply for 2/4-fold)
- Individual or parallel output (Parallel can expand the load capacity, only apply for 2/4-fold)
- Staircase lighting, Flashing switch and Delay switch, as well as Scene, Threshold, Forced operation, Safety operation and Operation hours counter
- Logic function, with AND, OR, XOR, Gate forwarding, Threshold comparator, Format convert, Gate function, Delay function and Staircase lighting
- Support the KNX Data Secure

### Chapter 2 Technical Data

|                                   |                              |   |
|-----------------------------------|------------------------------|---|
| <b>Power Supply</b>               | Bus voltage                  | 21-30V DC, via the KNX bus                                    |
|                                   | Bus current                  | <6mA/24V, <5.5mA/30V (1 fold)                                 |
|                                   |                              | <7mA/24V, <6mA/30V (2 fold)                                   |
|                                   |                              | <7.5mA/24V, <6.5mA/30V (4 fold)                               |
|                                   | Bus consumption              | <165mW (1 fold)   |
|                                   |                              | <180mW (2 fold)   |
| <195mW (4 fold)                   |                              |   |
| <b>Output</b>                     | Dimming channel              | 1/2/4 folds, separate phase connection                        |
|                                   | Max. output capacity         | 300W (per channel, Incandescent/ Halogen/ LED, trailing edge) |
|                                   |                              | Parallel: 2 channels 500W /3 channels 750W/                   |
|                                   |                              | 4 channel 1000W   |
|                                   | U <sub>n</sub> rated voltage | 110~230 V AC (50/60HZ)  |
|                                   | Protection                   | Short-circuit, Over-voltage, Over-temperature                 |
|                                   | Standby loss                 | Approx. 0.7W  |
| Power loss                        | ≤2W / per channel            |   |
| <b>Connection</b>                 | KNX                          | Bus connection terminals                                      |
|                                   | Outputs                      | Screw terminals   |
|                                   | Wire Range                   | 0.2–2.5mm <sup>2</sup> (1 fold)                               |
| 0.2–6.0mm <sup>2</sup> (2/4 fold) |                              |   |

|                              |                                |   |
|------------------------------|--------------------------------|---|
| <b>Operation and display</b> | Programming button and Red LED | For assigning the physical address                |
|                              | Green LED flashing             | For displaying application layer running normally |
|                              | Channel button                 | For manual switching or dimming                   |
|                              | Channel indication LED         | Indicates channel status of the load              |
|                              | Man./Auto. button              | Change the Man./Auto. mode                        |
|                              | Man./Auto. LED                 | Indicate the Man./Auto. mode status               |
| <b>Temperature</b>           | Operation                      | -5 °C ... + 45 °C                                 |
|                              | Storage                        | -25 °C ... + 55 °C                                |
|                              | Transport                      | - 25 °C ... + 70 °C                               |
| <b>Environment</b>           | Humidity                       | <93%, except dewing                               |
| <b>Mounting</b>              | On 35mm mounting rail          |   |
| <b>Dimension</b>             | 36 x 90 x 64 mm (1 fold)       |   |
|                              | 72 x 90 x 64 mm (2 fold)       |   |
|                              | 144 x 90 x 64 mm (4 fold)      |   |
| <b>Weight</b>                | 0.2kg (1 fold)                 |   |
|                              | 0.3kg (2 fold)                 |   |
|                              | 0.5kg (4 fold)                 |   |

### 2.1. Load type

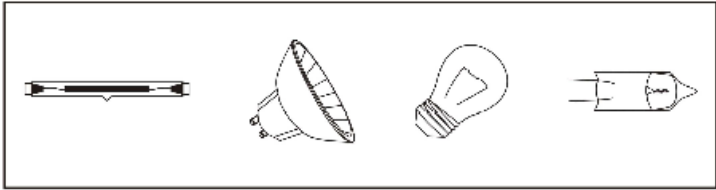
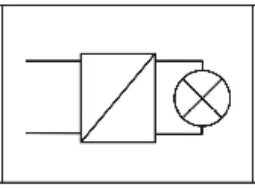
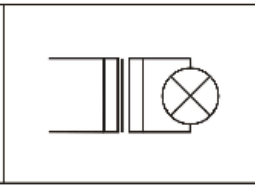
| Load type  | Max. Load capacity (110V)  |               | Max. Load capacity (230V) |               |
|--|--|---------------|---------------------------|---------------|
|  | Leading edge   | Trailing edge | Leading edge              | Trailing edge |
| Incandescent lamp  | 10...150W  | 10...150W     | 10...300W                 | 10...300W     |
| HV Halogen lamp  | 10...150W  | 10...150W     | 10...300W                 | 10...300W     |
| LV Halogen lamp with Electronic transformer                    | 10...150W  | 10...150W     | 10...300W                 | 10...300W     |
| HV LED   | 2...30W  | 2...150W      | 2...60W                   | 2...300W      |
| LV LED with Electronic transformer                             | 2...40W  | 2...150W      | 2...80W                   | 2...300W      |
| LV LED with Constant current driver<br>(Down light, Spotlight) | 2...40W  | 2...150W      | 2...80W                   | 2...300W      |
| LV LED with Constant voltage driver                            | 2...40W  | 2...150W      | 2...80W                   | 2...300W      |
| <b>Resistive load</b>  | <b>R</b>   |               |                           |               |
|  |  |               |                           |               |
| <b>Capacitive load</b>   | <b>C</b>   |               |                           |               |
|  |   |               |                           |               |
| <b>Inductive load</b>  | <b>L</b>   |               |                           |               |
|  |   |               |                           |               |

### LED load

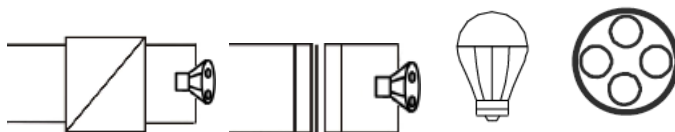

Individual or parallel outputs can be selected for 2/4-fold dimmer, and the parallel can expand the load capacity. Load type as following:

| Load type   | Max. Load capacity (110V) |               |                          |               |                          |               |
|---|---------------------------|---------------|--------------------------|---------------|--------------------------|---------------|
|   | Parallel with 2 channels  |               | Parallel with 3 channels |               | Parallel with 4 channels |               |
|   | Leading edge              | Trailing edge | Leading edge             | Trailing edge | Leading edge             | Trailing edge |
| Incandescent lamp   | 300W                      | 300W          | 400W                     | 400W          | 500W                     | 500W          |
| HV Halogen lamp   | 300W                      | 300W          | 400W                     | 400W          | 500W                     | 500W          |
| LV Halogen lamp with Electronic transformer                   | 300W                      | 300W          | 400W                     | 400W          | 500W                     | 500W          |
| HV LED  | -                         | 300W          | -                        | 400W          | -                        | 500W          |
| LV LED with Electronic transformer                            | -                         | 300W          | -                        | 400W          | -                        | 500W          |
| LV LED with Constant current driver<br>(Down light Spotlight) | -                         | 300W          | -                        | 400W          | -                        | 500W          |
| LV LED with Constant voltage driver                           | -                         | 300W          | -                        | 400W          | -                        | 500W          |

| Load type   | Max. Load capacity (230V) |               |                          |               |                          |               |
|---|---------------------------|---------------|--------------------------|---------------|--------------------------|---------------|
|   | Parallel with 2 channels  |               | Parallel with 3 channels |               | Parallel with 4 channels |               |
|   | Leading edge              | Trailing edge | Leading edge             | Trailing edge | Leading edge             | Trailing edge |
| Incandescent lamp   | 500W                      | 500W          | 750W                     | 750W          | 1000W                    | 1000W         |
| HV Halogen lamp   | 500W                      | 500W          | 750W                     | 750W          | 1000W                    | 1000W         |
| LV Halogen lamp with Electronic transformer                   | 500W                      | 500W          | 750W                     | 750W          | 1000W                    | 1000W         |
| HV LED  | -                         | 500W          | -                        | 750W          | -                        | 1000W         |
| LV LED with Electronic transformer                            | -                         | 500W          | -                        | 750W          | -                        | 1000W         |
| LV LED with Constant current driver<br>(Down light,Spotlight) | -                         | 500W          | -                        | 750W          | -                        | 1000W         |

|                                     |   |      |   |      |   |       |
|-------------------------------------|---|------|---|------|---|-------|
| LV LED with Constant voltage driver | - | 500W | - | 750W | - | 1000W |
|-------------------------------------|---|------|---|------|---|-------|

**Note:**

It is not permitted to connect inductive and capacitive loads together at the same output. However, mixing of loads such as capacitive + resistive loads or inductive + resistive loads is allowed to connect, but power reduction needs to be considered. It is more advisable to connect the same type of loads for an output.

The max. load capacity depends on the surge current and power loss of the lamp, these types of lamp will cause large heating and high surge current in leading edge mode, especially LED lamp, so it is not recommended to drive LED in leading edge mode, make sure the connected lamp do not trigger over-load or over-heating protection.

### 2.2.Operation mode

Dimmer system is dimming in leading or trailing edge.

#### 1.Dimming in leading edge:

Explanation of the dimming system: turn off dimmer in leading edge and turn on in trailing edge. As shown in the following figure, no voltage input from zero point until dimmer is turned on. It is suitable for inductive loads.

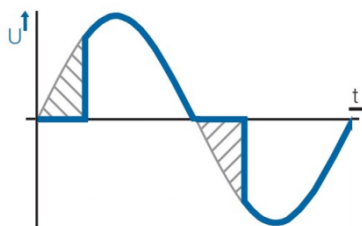

#### 2.Dimming in trailing edge:

Explanation of the dimming system: turn on dimmer in leading edge and turn off in trailing edge. As shown in the following figure, dimmer will be turned on the zero-crossing point, during this moment, the voltage is very low and there is no inrush current to the load. In this way, there is no minimum load requirement, so that allows for better performance of a single lighting or a very small load and extends the life of the lamp, as well as reduce the interference to the power grid. It is suitable for resistive or capacitive loads.

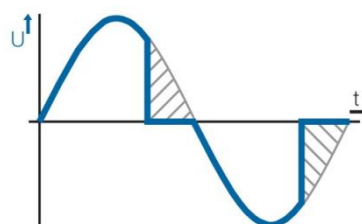

### Chapter 3 Dimension and Connection Diagram

#### 3.1. Dimension drawing

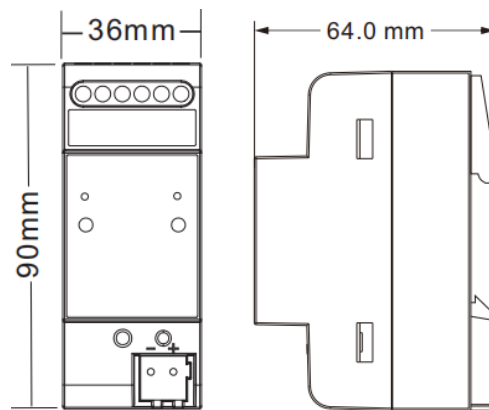

1-Fold

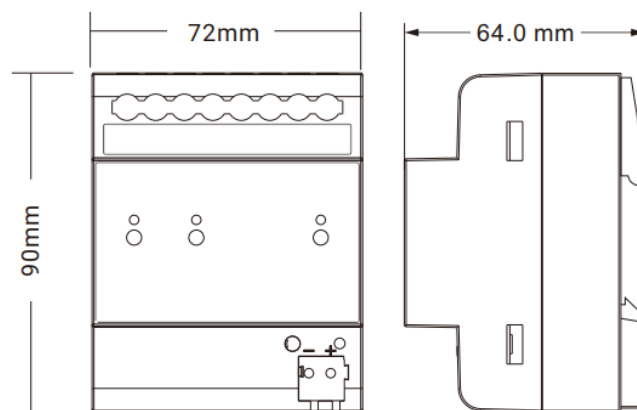

2-Fold

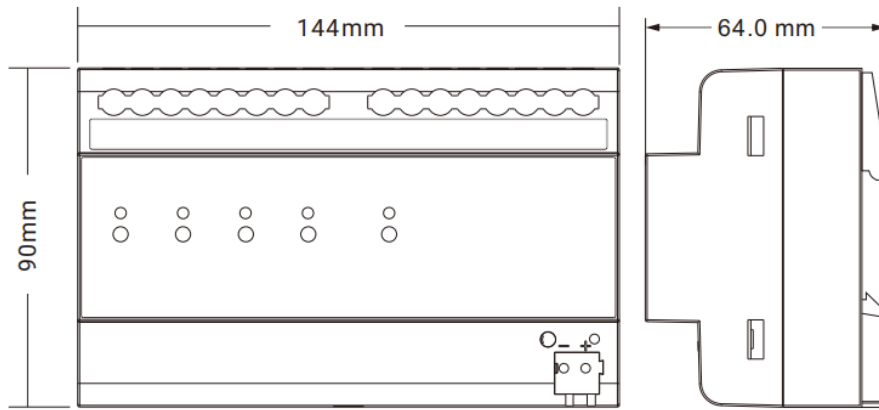

4-Fold

### 3.2.Connection Diagram

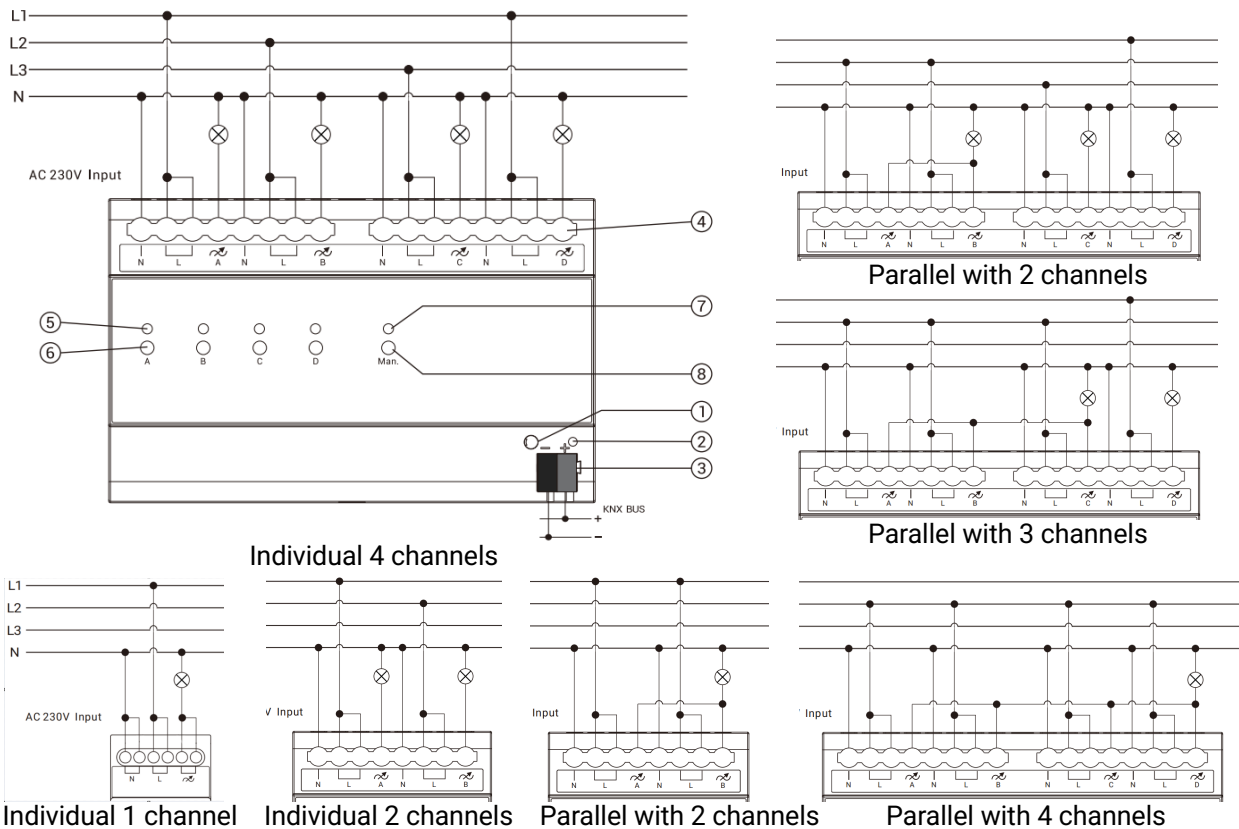

① Programming button

② Programming LED

③ KNX bus connection terminal

④ Input, Output, load terminal

⑤ Channel indication LED: in normal mode, LED off is the lamp off, LED on is the lamp on; in manual mode, flashing slowly is dimming manually. Flashing fast is channel abnormality (Short-circuit, Over-voltage, Over-temperature, Operating voltage failure)

⑥Channel button: when no ETS configuration, press to switch on/off; in manual mode, short press to switch on/off, long press for dimming up/down, long press then release to stop dimming

⑦⑧Man./Auto. operation switch button and status indicating LED:

Long press to switchover Man. and Auto. mode, LED on is Man. mode and off is Auto. mode.

**Reset the device to the factory configuration: press the programming button and hold for 4 seconds then release, repeat the operation for 4 times, and the interval between each operation is less than 3 seconds**

### Chapter 4 Project Design and Programming

| Application                                     | Maximum of communication objects | Maximum number of group addresses | Maximum number of associations | Secure group addresses |
|---|----------------------------------|-----------------------------------|--------------------------------|------------------------|
| <b>KNX General Dimming Actuator, 1-Fold/1.0</b> | <b>237</b>                       | <b>280</b>                        | <b>280</b>                     | <b>160</b>             |
| <b>KNX General Dimming Actuator, 2-Fold/1.0</b> | <b>237</b>                       | <b>280</b>                        | <b>280</b>                     | <b>200</b>             |
| <b>KNX General Dimming Actuator, 4-Fold/1.0</b> | <b>237</b>                       | <b>280</b>                        | <b>280</b>                     | <b>280</b>             |

#### General function

General function includes device In operation setting, central control (Switch, Dimming), safety function, as well as manual operation and output indication function.

In addition, central control function only applies for 2/4-Fold Dimmers, and it is not supported by 1-Fold Dimmer.

#### Output channel

There are 1/2/4 output channels according to the product type, support to switch, relative dimming/absolute dimming, feed back the status of switch, brightness and the abnormal status (short-circuit, over-voltage, over-temperature and operating voltage failure), as well as reset behaviour after download/bus failure/bus recovery. Individual or parallel outputs can be selected, and the parallel can expand the load capacity, which only applies for 2/4-fold.

Load types and dimming curves can be independently configured, as well as extension functions including Staircase lighting, Flashing switch, Delay switch, Scene, Threshold, Forced operation, Safety operation and Operation hours counter.

For output function, the definition of function priority: Manual > Forced > Safety > other functions, after exiting higher priority, the next priority action needs to be executed.

### **Logic function**

Up to support 8 channels of logic, each channel up to support 8 inputs and 1 logic result.

Logic function support functions, including AND, OR, XOR, Gate forwarding, Threshold comparator, Format convert, Gate function, Delay function and Staircase lighting.

## Chapter 5 Parameter setting description in the ETS

### 5.1.KNX Secure

Dimmer is a KNX device that complies with the KNX secure standard. That is, you can run the device in data secure mode.

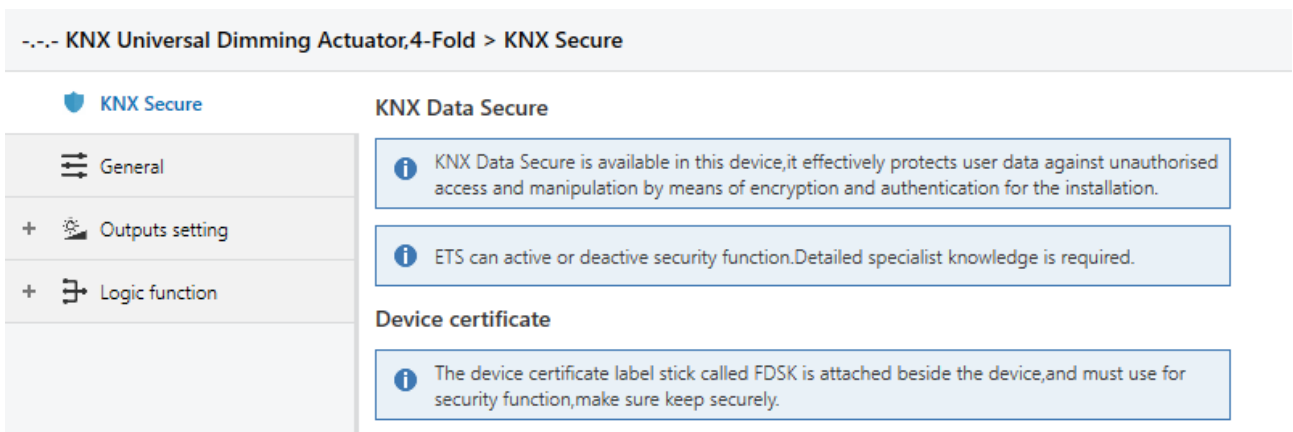
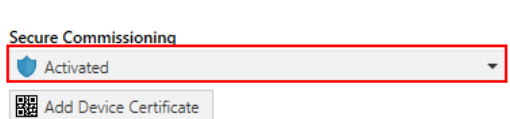

Fig.5.1 (1) "KNX Secure" parameter window

The device with KNX secure will be displayed notes on ETS, as shown as Fig.5.1(1).

If secure commissioning is activated in ETS project, the following information must be considered during device debugging:



❖ It is essential to assign a project password as soon as a KNX Secure device is imported into a project.

This will protect the project against unauthorized access.

The password must be kept in a safe place – access to the project is not possible without it (not even the KNX Association or device manufacturer will be able to access it)!

Without the project password, the commissioning key will not be able to be imported.

❖ A commissioning key is required when commissioning a KNX Secure device (first download). This key (FDSK = Factory Default Setup Key) is included on a sticker on the side of the device, and it must be imported into the ETS prior to the first download:

❖ On the first download of the device, a window pops up in the ETS to prompt the user to enter the key, as shown in Fig.5.1 (2) below.

The certificate can also be read from the device using a QR scanner (recommended).



Fig.5.1(2) Add Device Certificate window

❖ Alternatively, the certificates of all Secure devices can be entered in the ETS beforehand.

This is done on the "Security" tab on the project overview page, as shown in Fig.5.1(3) below.

The certificates can be also added to the selected device in the project, as shown in Fig.5.1(4).

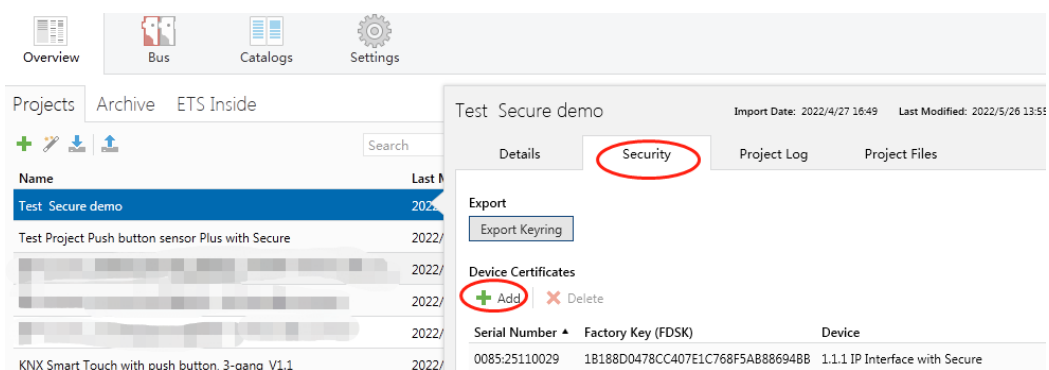

Fig.5.1(3) Add Device Certificate

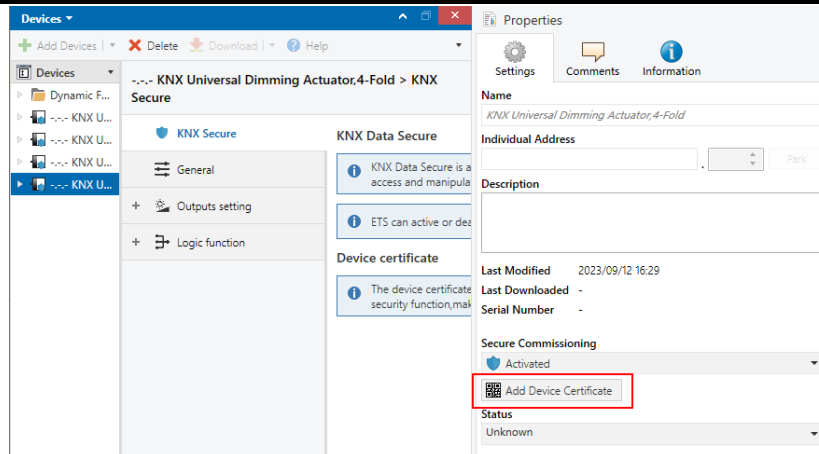

Fig.5.1(4) Add Device Certificate

✧ There is a FDSK sticker on the device, which is used for viewing FDSK number.

**Without the FDSK, it will no longer be possible to operate the device in KNX Secure mode after a reset.**

The FDSK is required only for initial commissioning. After entering the initial FDSK, the ETS will assign a new key, as shown in Fig.5.1(5) below.

The FDSK will be required again only if the device was reset to its factory settings (e.g. If the device is to be used in a different ETS project).

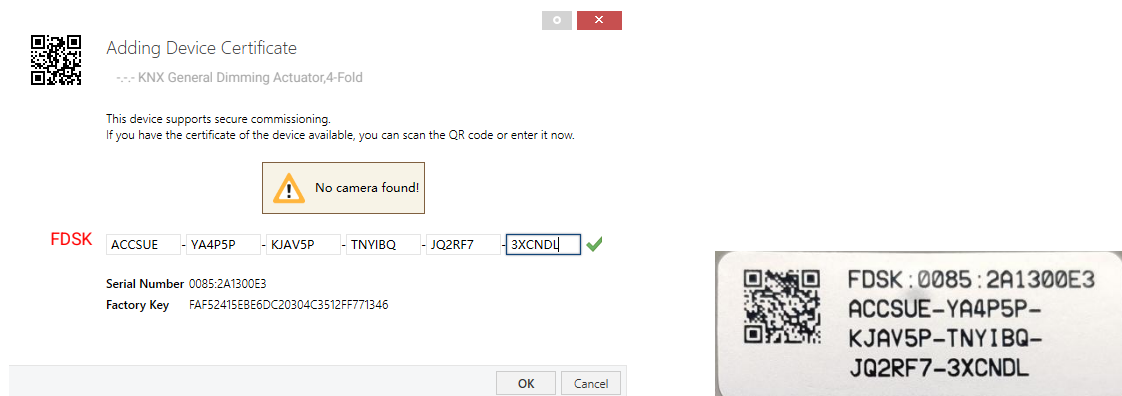

Fig.5.1(5)

Example:

If this application in the project needs to be tried with another device, it is no longer the original device. When the application is downloaded to a new device, the following prompt will appear on the left of Fig.5.1(6), click yes, the Add Device Certificate window will appear, then enter the initial FDSK of the new device, and you need to reset the device to the factory settings (it is not required if the device is still factory default; If it has been used, it will be required to reset, otherwise the following error message will

appear on the right of Fig.5.1(6)), and then the device can be successfully downloaded again.

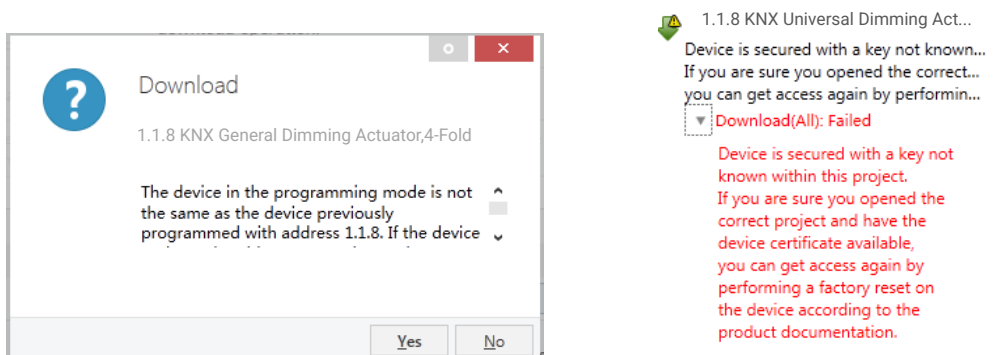

Fig.5.1(6) Example

Whether the device is replaced in the same project, or the device is replaced in a different project, the processing is similar: **Reset the device to the factory settings, then reassign the FDSK.**

After the device is downloaded successfully, the label Add Device Certificate turns gray, indicating that the key for this device has been assigned successfully, as shown in Fig.5.1(7) below.

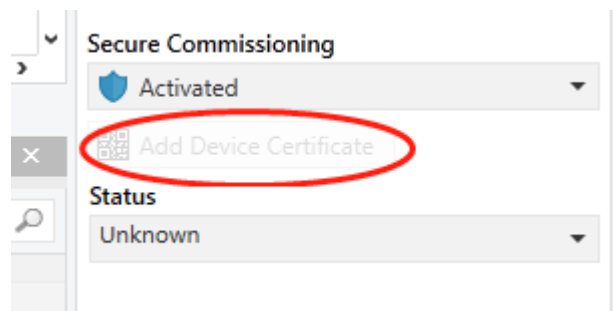

Fig.5.1(7)

ETS generates and manages keys:

Keys and passwords can be exported as needed to the use of security keys outside of the associated ETS projects. As shown in Fig.5.1(8) below, the file extension is .knxkeys.

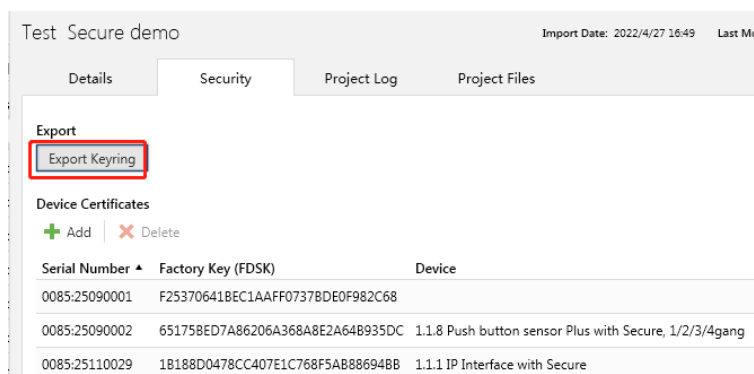

Fig.5.1(8)

**Note:** Any USB interface used for programming a KNX Secure device must support "long frames".  
Otherwise ETS will report a download failure information, as shown below.

### 5.2.Parameter window "General"

| --- KNX Universal Dimming Actuator,4-Fold > General   |   |  |
|---|---|--|
| <input checked="" type="checkbox"/> KNX Secure        | Operation and send delay after bus recovery [0..15]       | 0 s  |
| <input checked="" type="checkbox"/> General           | Send cycle of "In operation" telegram [1..240,0=inactive] | 0 s  |
| + <input checked="" type="checkbox"/> Outputs setting | Manual operation  | <input checked="" type="checkbox"/>  |
| + <input checked="" type="checkbox"/> Logic function  | Manual to automatic by                                    | <input type="radio"/> Only long press<br><input checked="" type="radio"/> Both long press and automatic delay time |
|   | Delay time [10...6000]                                    | 10 s   |
|   | Safety function   | <input checked="" type="radio"/> Cancel via object value "0"<br><input type="radio"/> Cancel via object value "1"  |
|   | Monitoring period [0...1000, 0=monitoring deactive]       | 0 s  |
|   | Logic function  | <input checked="" type="checkbox"/>  |

Fig.5.2 "General setting" parameter window

#### Parameter "Operation and Send delay after bus recovery [0..15]"

This parameter is for setting the delay time to send to bus after the device bus recovery.

Options: **0..15 s**

The setting dose not contain the device initialization time, and bus telegrams received during delay

time will be recorded.

### Parameter "Send cycle of "In operation" telegram [1..240,0=inactive]"

This parameter is for setting the time interval when cyclically send telegrams through the bus to indicate this device in normal operation. When set to "0", the object "In operation" will not send a telegram. If the setting is not "0", the object "In operation" will send a telegram according to the setting period time with logic "1" to the bus. Options: **0...240 s, 0= inactive**

As to reduce the bus load as much as possible, the maximum time interval should be selected according to actual application requirement.

### Parameter "Manual operation"

This parameter is for setting whether to enable manual operation, which is mainly convenient for engineers to debug or check the lamps, when enabled, you can manually switch and dim each output channel.

**The definition of function priority: Manual > Forced > Safety > other functions, after exiting higher priority, the next priority action needs to be executed. When during manual operation, the telegrams from bus will be ignored and not executed, but the statuses of low priority (Forced/Safety) will be recorded in the background, and they will be executed after exiting manual operation.**

**Manual operation is enabled by default in case of no database; after download, enable manual or not depends on the parameter.**

Theses two parameters as follow are visible when enabled:

#### Parameter "Manual to automatic by"

This parameter is for setting the behaviour when exit manual operation. Options:

**Only long press**

**Both long press and automatic delay time**

#### Parameter "Delay time [10...6000]"

This parameter is visible when "Both long press and automatic delay time" is selected by previous parameter. Set the delay time for exiting manual operation automatically, and timing from the last button operation. Options: **10....6000 s**

### Parameter "Safety function"

This parameter is for setting the object value of safety status cancellation for whole device, while receiving the reversed value is to enter safety status. Options:

**Cancel via object value "0"**

**Cancel via object value "1"**

When enter safety status, execute the configured behaviour of the channel if its safety function is enabled, more details are defined in the channel.

### Parameter "Monitoring period [0...1000, 0=monitoring deactive]"

This parameter is for setting the period to monitor the telegram of safety object.

Options: **0...1000 s**

If the period is greater than 0, the telegram to cancel safety status was not received during the monitoring period, enter the safety status. Exit this status and reset the monitoring period when a cancellation telegram is received. It is also possible to enter the safety status directly by receiving the reversed value defined by the previous parameter.

If the period is set as 0, enter the safety status directly by receiving the reversed value defined by the previous parameter, and receiving cancellation value is to exit the status.

### Parameter "Logic function"

Setting page of logic function interface is visible after this parameter enabled.

### 5.3. Parameter window "Output setting"

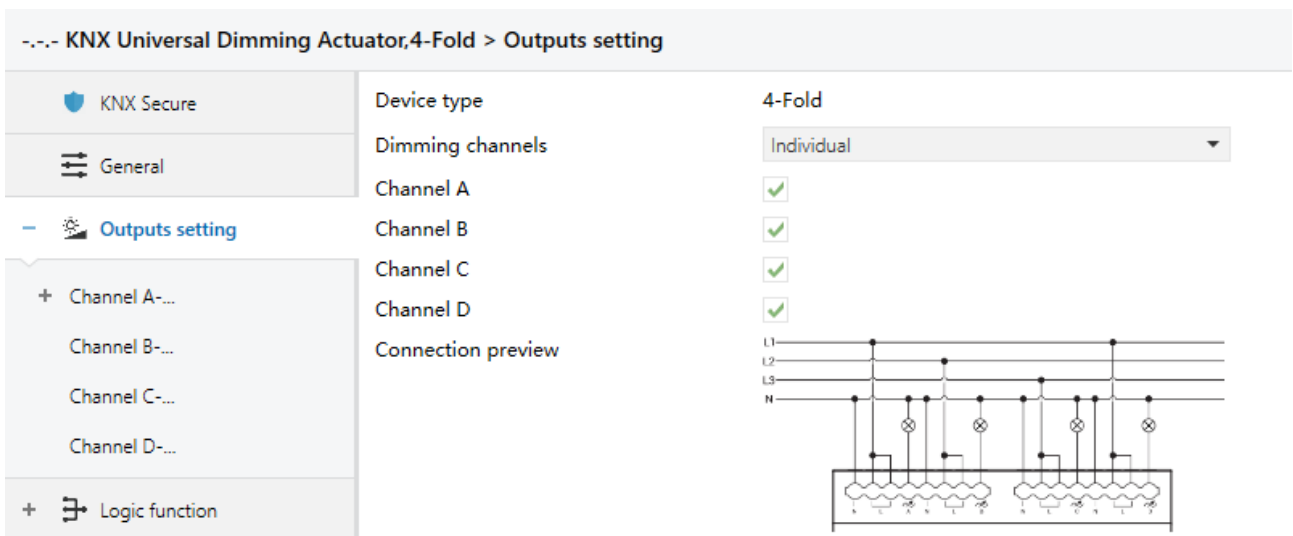

Fig.5.3 "Output setting" parameter window

#### Parameter "Device type"

This parameter is for displaying the device type, it is according to the product:

**1-Fold**

**2-Fold**

**4-Fold**

Display corresponding connection preview below the parameter.

#### Parameter "Dimming channels"

This parameter is visible when device type is 2-Fold or 4-Fold. Set the dimming channels. For the dimmer with multiple channels, individual or parallel channels can be configure. Parallel channels can expand the load capacity.

When 2-Fold, options:

**Individual**

**Parallel (A+B)**

When 4-Fold, options:

**Individual**

**Parallel (A+B) and Parallel (C+D)**

**Parallel (A+B) and Individual (C, D)**

**Individual (A, B) and Parallel (C+D)**

**Parallel (A+B+C) and Individual (D)**

**Individual (A) and Parallel (B+C+D)**

**Parallel (A+B+C+D)**

### Parameter "Channel A/B/C/D/A+B/..."

For the dimmer with multiple channels, these parameters are visible depends on the previous parameter. Set whether to enable dimming channel, and corresponding window is visible when enabled.

**For 1-Fold Dimmer, only display Channel A.**

Configuration of individual channel is as same as the parallel channel, the following is an example of Channel A.

### 5.3.1. Parameter window "Channel"

--- KNX Universal Dimming Actuator,4-Fold > Outputs setting > Channel A-...

|  |   |
|--|---|
| <ul style="list-style-type: none"> <li>KNX Secure</li> <li>General</li> <li>Outputs setting <ul style="list-style-type: none"> <li><b>Channel A-...</b></li> <li>User defined dimming cur...</li> <li>Scene function</li> <li>Time function</li> <li>Threshold function</li> <li>Forced function</li> <li>Safety function</li> <li>Operating hours counter</li> <li>Channel B-...</li> <li>Channel C-...</li> <li>Channel D-...</li> </ul> </li> <li>Logic function</li> </ul> | <p>Description (max 30char.)</p> <p>Load type: LED (trailing edge)</p> <p>Dimming curve: User defined</p> <hr/> <p>General dimming time (from min. to max.): 4 s</p> <p>Minimum brightness value: 1 %</p> <p>Maximum brightness value: 100 %</p> <hr/> <p>Switching on value: <input type="radio"/> Preset brightness value <input checked="" type="radio"/> Last brightness value</p> <p>Dimming mode selection for switching on: <input type="radio"/> Jumping <input checked="" type="radio"/> Dimming</p> <p>Dimming mode selection for switching off: <input checked="" type="radio"/> Jumping <input type="radio"/> Dimming</p> <p>Dimming time for relative dimming: 4 s</p> <p>Dimming time for absolute dimming: 4 s</p> <p>Allow switch off via relative dimming: <input checked="" type="checkbox"/></p> <p>Absolute dimming value lower than the minimum value: 0%=0%, otherwise=Minimum brightness value</p> <hr/> <p>Additional startup characteristic when the lamp is off: <input checked="" type="checkbox"/></p> <p>Startup brightness value: 50 %</p> <p>Behavior for dimming up: Dim up based on the startup brightness</p> <p>Behavior when the switch or dimming value is lower than startup value: Jump to startup brightness</p> <hr/> <p><b>Reset behavior</b></p> <p>Behavior after download: Switching off</p> <p>Behavior after bus failure: No reaction</p> <p>Behavior after bus recovery: Brightness before bus failure</p> <hr/> <p>Short-circuit detect for operating supply or device reset if output is off: <input checked="" type="checkbox"/></p> |
|--|---|

**i** Note:the short-circuit detect may occur a briefly flashing for some lamps

Fig.5.3.1(1) "Channel" parameter window

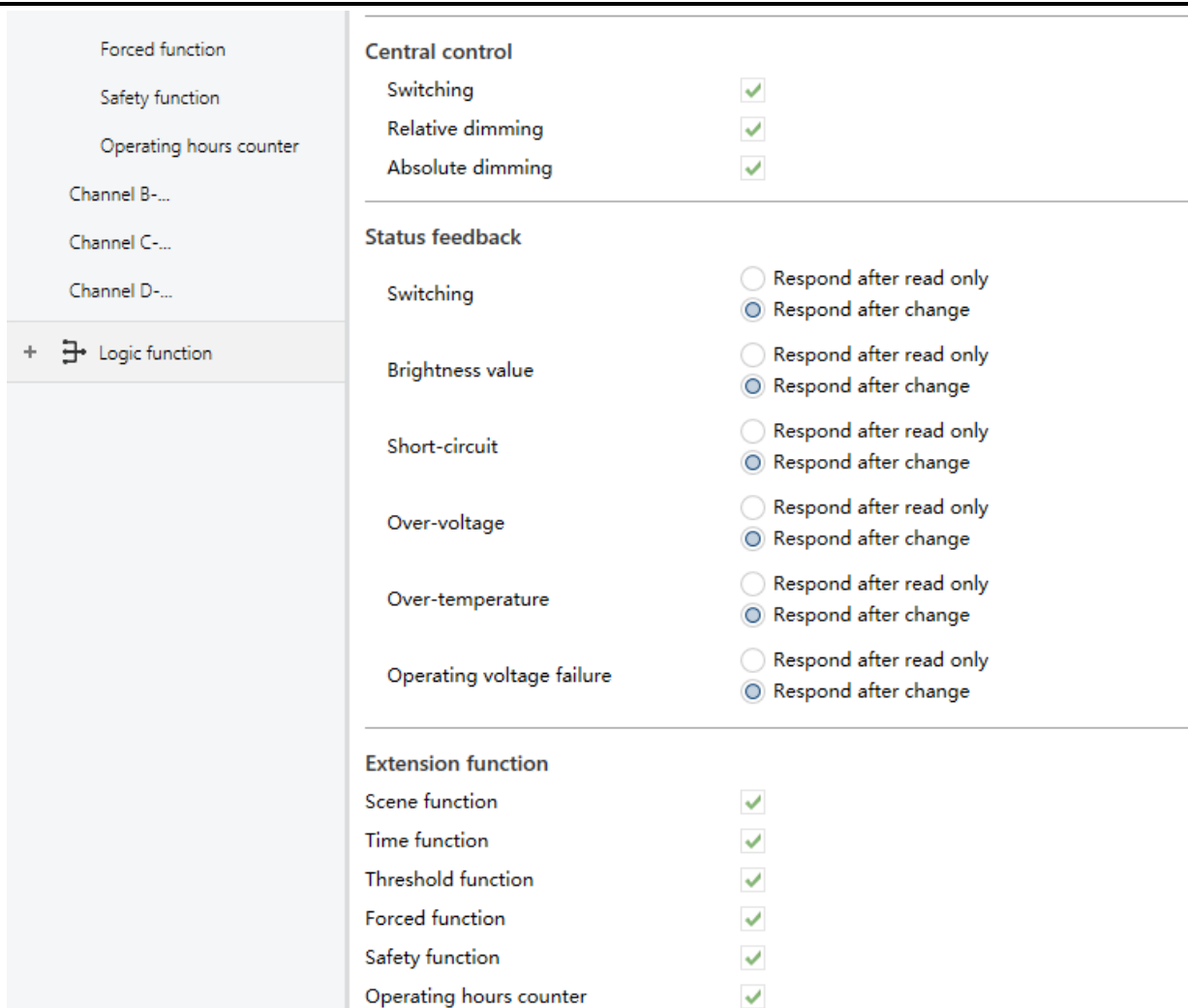

Fig.5.3.1(2) "Channel" parameter window

### Parameter "Description (max 30char.)"

This parameter is for setting the name description of the channel.

### Parameter "Load type"

This parameter is for setting the load type of the channel. Options:

**Resistive&Capacitive load (trailing edge)**

**Inductive load (leading edge)**

**LED (trailing edge)**

**LED (leading edge)**

### Parameter "Dimming curve"

This parameter is for setting dimming cure of the channel, display corresponding preview figure below the parameter. Options:

### Logarithmic function

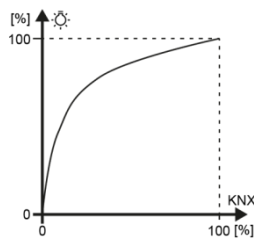

### Cubic function

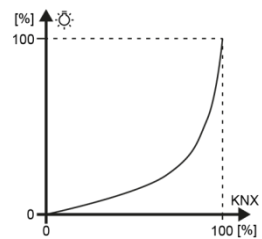

### Root function

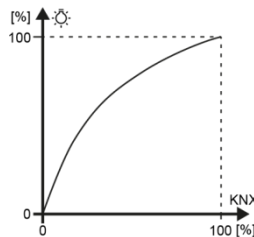

### Exponential function

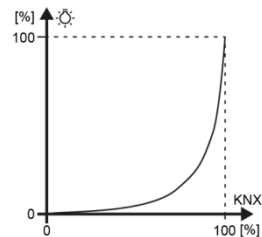

### Linear function

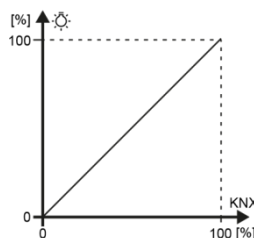

### User defined

### Quadratic function

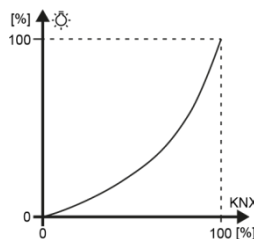

When "User defined" is selected, user can custom a dimming curve, more detail please refer to chapter 5.3.2.

### Parameter "General dimming time (from min. to max.)"

This parameter is for setting the time for the whole dimming process, which refers to the time from minimum to maximum value. Suppose the time is set as 6s, the min. Value is 0% and the max. is 100%, if the brightness is only dimmed from 0% to 50%, then the dimming time only takes 3s.

Options: **2...255 s**

If the channel function has not specified a dimming time, use the time set by this parameter, functions such as switch on/off lamps, forced, safety, staircase lighting, threshold, etc.

### Parameter "Minimum brightness value"

### Parameter "Maximum brightness value"

These parameters are for setting minimum and maximum brightness values individually, to limit the output range of dimming brightness, which is allow the lamps work in a better brightness range depending on the environment or lamps compatibility.

This range is not allowed to be exceeded in any status of lamps on, including threshold, forced, safety functions, etc. Output as min. value when the brightness is lower than the min., and output as max. value when it is higher than the max.

Options of the min. value: **1...49 %**; Options of the max. value: **50...100 %**

### Parameter "Switching on value"

This parameter is for setting the brightness when the lamp is switched on. Options:

#### **Preset brightness value**

#### **Last brightness value**

Last brightness value: When the device is powered on for the first time or restarted after downloading, the default value for " Switch ON" is 50%, meaning the brightness value is 50%.

#### **Parameter "Preset brightness value"**

This parameter is visible when previous parameter is selected "Preset brightness value". Set the preset brightness value. Options: **1...100 %**

### Parameter "Dimming mode selection for switching on"

This parameter is for setting the dimming mode when the lamp is switched on. Options:

#### **Jumping**

#### **Dimming**

Jumping: switch on immediately and directly to the target brightness.

Dimming: switch on with dimming to the target brightness and use the General dimming time.

### Parameter "Dimming mode selection for switching off"

This parameter is for setting the dimming mode when the lamp is switched off. Options:

#### **Jumping**

#### **Dimming**

Jumping: switch off immediately.

Dimming: switch off with dimming and use the General dimming time.

### Parameter "Dimming time for relative dimming"

This parameter is for setting the time for the whole relative dimming process. Options: **2...255 s**

### Parameter "Dimming time for absolute dimming"

This parameter is for setting the time for the whole absolute dimming process. Options: **2...255 s**

### Parameter "Allow switch off via relative dimming"

This parameter is for setting whether allow to switch lamp off via relative dimming. When disabled, it can only be adjusted downward to the minimum brightness value; while enabled, switch the lamp off directly when the brightness is dimming to less than the minimum brightness value.

### Parameter "Absolute dimming value lower than the minimum value"

This parameter is for setting the behaviour when absolute dimming value lower than the minimum value, **it only affects the object "Absolute dimming"**. Options:

**0%=0%, otherwise=Minimum brightness value**

**To be the minimum brightness value**

**To be 0%**

0%=0%, otherwise=Minimum brightness value%: output as min. value when the value is lower than the min., but the value is 0% is to switch the lamp off.

To be the minimum brightness value: output as min. value when the value is lower than the min., even if the value is 0%.

To be 0%: switch the lamp off directly when the value is lower than the min.

### Parameter "Additional startup characteristic when the lamp is off"

This parameter is for setting whether the lamp needs the startup characteristic additionally when the lamp is off. Some lamps require a higher voltage to start up when switched off.

Following four parameters are visible when parameter is enabled.

### Parameter "Startup brightness value"

This parameter is for setting the brightness value of lamp startup. Options: **5..90 %**

**Note: the brightness must not exceed the max. and min. value, otherwise it cannot be set in the**

### ETS.

#### Parameter "Behavior for dimming up"

This parameter is for setting the behavior for dimming up when the lamp is off. Options:

**Ignore the telegram**

**Like normal**

**Dim up based on the startup brightness**

Ignore the telegram: feed back an off telegram immediately to synchronize the status with the control device.

Like normal: dimming up and output normally.

Dim up based on the startup brightness: use the startup brightness as a based point, and dimming up from this brightness.

#### Parameter "Behavior when the switch or dimming value is lower than startup value"

This parameter is for setting the behavior when the target brightness is lower than startup value, and the lamp is off. Options:

**Ignore the telegram**

**Like normal**

**Jump to startup brightness**

**Jump to startup then delay to target**

Ignore the telegram: feed back a off telegram immediately to synchronize the status with the control device.

Like normal: dimming and output normally.

Jump to startup brightness: jump to the startup brightness immediately and feed back the new brightness to the bus.

Jump to startup then delay to target: jump to startup brightness firstly then dimming to the target brightness after the delay has elapsed.

If the target brightness is higher than startup value, dimming from the startup value to the target brightness directly, it is only applied to receive the telegrams of objects "Switching" and "Absolute dimming".

#### Parameter "Delay time after reach startup"

This parameter is visible when previous parameter is selected "Jump to startup then delay to target".

Set the delay time for dimming to target brightness after reaching the startup value. Options:

**50ms**

**80ms**

**100ms**

...

**2s**

**4s**

**5s**

### Reset behavior

#### Parameter "Behavior after download"

This parameter is for setting the behaviour of channel after download. Options:

**Switching off**

**Preset brightness value**

**Brightness before bus failure**

Preset brightness value: dimming to a setting brightness, defined by next parameter.

Brightness before bus failure: recover to the brightness value stored when the bus failure.

#### Parameter "Preset brightness value"

This parameter is visible when "Preset brightness value" is selected. Set the preset brightness value.

Options: **1...100 %**

#### Parameter "Behavior after bus failure"

This parameter is for setting the behaviour of channel after bus failure. Options:

**Switching off**

**Preset brightness value**

**No reaction**

Preset brightness value: dimming to a setting brightness, defined by next parameter.

---

### Parameter "Preset brightness value"

This parameter is visible when "Preset brightness value" is selected. Set the preset brightness value.

Options: 1...100 %

### Parameter "Behavior after bus recovery"

This parameter is for setting the behaviour of channel after bus recovery.

#### Switching off

#### Preset brightness value

#### Brightness before bus failure

Preset brightness value: dimming to a setting brightness, defined by next parameter.

Brightness before bus failure: recover to the brightness value stored when the bus failure.

### Parameter "Preset brightness value"

This parameter is visible when "Preset brightness value" is selected. Set the preset brightness value.

Options: 1...100 %

### Parameter "Short-circuit detect for operating supply or device reset if output is off"

This parameter is for setting whether detect short-circuit for operating supply or device reset if output is off.

When disabled, a short-circuit may be detected only when turn on the lamp until exceed the threshold of short-circuit detection.

When enabled, every time a operating supply or device voltage recovery, it needs to detect a short-circuit firstly if initially the lamp is off or the brightness is lower than the threshold of short-circuit detection, but it is not required to detect if the brightness is higher than the threshold of short-circuit detection. Download database and restart, if the detection has been normal before the download, there is no need to repeat the detection, otherwise it is still necessary to perform a detection.

 Note: the short-circuit detect may occur a briefly flashing for some lamps

## Central control

Central control is used to control the switching and dimming of all channels, each channel can be configured to support central control or not. When receive the telegram of central control from bus,

control the outputs centrally for the supported channels.

**Note: central control function only applies for 2/4-Fold Dimmers, and it is not supported by 1-Fold Dimmer.**

### Parameter "Switching"

This parameter is for setting whether control switch centrally.

### Parameter "Relative dimming"

This parameter is for setting whether control relative dimming centrally.

### Parameter "Absolute dimming"

This parameter is for setting whether control absolute dimming centrally.

## Status feedback

### Parameter "Switching/Brightness value/Short-circuit/Over-voltage/Over-temperature/Operating voltage failure"

These parameters are for setting the way to feed back the status of switch, brightness and abnormal status. The abnormal status including short-circuit, over-voltage, over-temperature, operating voltage failure. Options:

**Respond after read only**

**Respond after change**

Handling of abnormal status:

Trigger hardware protection when channel load terminal is short-circuited, and feed back the status to bus. It will disconnect the output when in protection. If it is the first time a short-circuit has been detected since power on, disconnect the output first then wait a 1 minute to output the current control value again; but if there is still a short-circuit, disconnect the output permanently, and cannot be used unless the device is restarted.

Trigger hardware protection when the operated voltage is higher than the rated voltage, and feed back the status to bus. It will disconnect the output when in protection.

When the measured internal temperature exceeds 90°C for 10s, then will trigger over-temperature

---

protection and send the status to bus. The brightness will down to 20% or to the minimum value under the protection status. After the temperature is reduced to below 70°C, output normally if a new control telegram is received.

Operation voltage is failure when no valid over-zero signal is detected, and feed back the status to bus. When in voltage failure, it can not feed back control status and no drive signal if receive the control telegram, need to power supply normally and has actual output value can feed back the current status of the lamp.

### Extension function

#### Parameter "Scene function"

Setting page of scene function interface is visible after this parameter enabled.

#### Parameter "Time function"

Setting page of time function interface is visible after this parameter enabled.

#### Parameter "Threshold function"

Setting page of threshold function interface is visible after this parameter enabled.

#### Parameter "Forced function"

Setting page of forced function interface is visible after this parameter enabled.

#### Parameter "Safety function"

Setting page of safety function interface is visible after this parameter enabled.

#### Parameter "Operating hours counter"

Setting page of operating hours counter interface is visible after this parameter enabled.

### 5.3.2. Parameter window "User defined dimming curve"

--- KNX Universal Dimming Actuator,4-Fold > Outputs setting > Channel A-... > User defined dimming curve

|  |   |
|--|---|
| <ul style="list-style-type: none"> <li>KNX Secure</li> <li>General</li> <li>Outputs setting</li> <li>Channel A-... <ul style="list-style-type: none"> <li><b>User defined dimming c...</b></li> <li>Scene function</li> <li>Time function</li> <li>Threshold function</li> <li>Forced function</li> <li>Safety function</li> <li>Operating hours counter</li> </ul> </li> <li>Channel B-...</li> <li>Channel C-...</li> <li>Channel D-...</li> </ul> | <p>Number of curve coordinate points <input type="text" value="4"/></p> <hr/> <p><b>Coordinate point 1</b></p> <p>KNX dimming value <input type="text" value="1"/> %</p> <p>Output value <input type="text" value="1"/> %</p> <hr/> <p><b>Coordinate point 2</b></p> <p>KNX dimming value <input type="text" value="10"/> %</p> <p>Output value <input type="text" value="10"/> %</p> <hr/> <p><b>Coordinate point 3</b></p> <p>KNX dimming value <input type="text" value="20"/> %</p> <p>Output value <input type="text" value="20"/> %</p> <hr/> <p><b>Coordinate point 4</b></p> <p>KNX dimming value <input type="text" value="100"/> %</p> <p>Output value <input type="text" value="100"/> %</p> |
|--|---|

Fig.5.3.2 "User defined dimming curve" parameter window

#### Parameter "Number of curve coordinate points"

This parameter is for setting the number of curve coordinate points. Options: **2...16**

#### Coordinate point x (x=1~16)

#### Parameter "KNX dimming value"

This parameter is for setting KNX dimming value of the curve. Options: **1..100%**

For user defined dimming curve, the first and the last one points are fixed to 1% and 100%.

**Note: the previous KNX dimming value must be small than next one, otherwise it can not be set on the ETS:**

### Coordinate point 2

KNX dimming value  %

Output value  %

### Coordinate point 3

KNX dimming value  %

Output value  %

### Parameter "Output value"

This parameter is for setting the output value corresponding to the KNX dimming value.

Options: **1..100%**

**Note: the previous output value must be small than next one, otherwise it can not be set on the ETS:**

### Coordinate point 2

KNX dimming value  %

Output value  %

### Coordinate point 3

KNX dimming value  %

Output value  %

Custom curves with different number of coordinate points, as shown as following:

Example 1

(3 coordinate points)

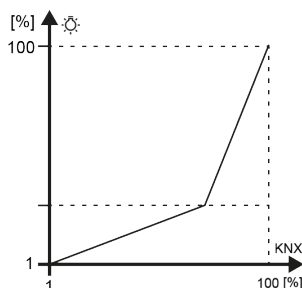

Example 2

(4 coordinate points)

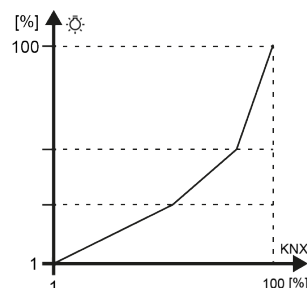

Example 3

(5 coordinate points)

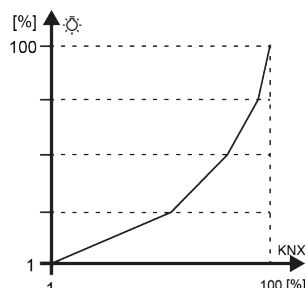

Example 4

(6 coordinate points)

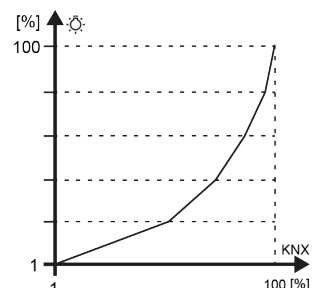

Commissioning steps of User defined dimming curve:

Step 1: use the linear function curve at first to determine the adjustable range, then obtain the minimum and maximum adjustable brightness values of the applied lamp with absolute dimming;

Step 2: when testing in step 1, you can experience the brightness changes with relative dimming, then checking the number of curve areas and coordinate points;

Step 3: the minimum brightness value is the point of knx value 1%, the maximum brightness value is the point of knx value 100%;

Step 4: add the coordinate points of the middle section according to the planning area;

Step 5: download and commission, according to the experience of dimming process, there may also be slight adjustment of the coordinate points or increase the configuration areas, and even need to adjust the dimming time, until achieve the best results for user satisfaction.

### **5.3.3.Parameter window "Extension function"**

Parameter windows are visible according to the enabling of the extension function parameters.

### 5.3.3.1. Parameter window "Scene function"

--- KNX Universal Dimming Actuator,4-Fold > Outputs setting > Channel A-... > Scene function

KNX Secure

General

Outputs setting

Channel A-...

User defined dimming cur...

Scene function

Time function

Threshold function

Forced function

Safety function

Operating hours counter

Channel B-...

Channel C-...

Channel D-...

Logic function

Overwrite scene stored values during download

| Scenes   | Description | Scene NO. | Brightness | Dimming |
|----------|-------------|-----------|------------|---------|
| Scene 1  |             | 1         | 50 %       | 4 s     |
| Scene 2  |             | 2         | 50 %       | 4 s     |
| Scene 3  |             | 3         | 50 %       | 4 s     |
| Scene 4  |             | 7         | 50 %       | 4 s     |
| Scene 5  |             | 8         | 50 %       | 4 s     |
| Scene 6  |             | 0         | NA         | NA      |
| Scene 7  |             | 0         | NA         | NA      |
| Scene 8  |             | 0         | NA         | NA      |
| Scene 9  |             | 0         | NA         | NA      |
| Scene 10 |             | 0         | NA         | NA      |
| Scene 11 |             | 0         | NA         | NA      |
| Scene 12 |             | 0         | NA         | NA      |
| Scene 13 |             | 0         | NA         | NA      |
| Scene 14 |             | 0         | NA         | NA      |
| Scene 15 |             | 0         | NA         | NA      |
| Scene 16 |             | 0         | NA         | NA      |

Fig.5.3.3.1 "Scene function" parameter window

Scene function can work with the control panel or other software to execute the setting scene and output the specified brightness.

#### Parameter "Overwrite scene stored values during download"

This parameter is for setting whether to override the scene stored values during application download. If select to overwrite, follow the parameter setting, otherwise for the brightness value corresponding to the scene number that has saved the modified value has executed, the last saved value will remain; for the modified brightness has not executed, still use the value set by parameter.

#### Scene x (x=1~16)



#### Parameter "Description"

This parameter is for setting the name description of the corresponding scene, up to 30 characters.

### Parameter "Scene NO."

This parameter is for setting the triggered scene number, up to 16 scenes. Options: **0...64**

When scene number is 0, it is invalid, and the brightness and dimming time cannot be set, as shown as following:

| Scenes  | Description | Scene NO.   | Brightness | Dimming |
|---------|-------------|---|------------|---------|
| Scene 1 |             | 0   | NA         | NA      |

When scene numbers are greater than 0, if there are same scene numbers, display following error message:

 Exist multiple scene NO. assignment conflict, the valid scene NO. can't be the same, please correct, otherwise only the first one of those conflict scene is valid and others will be ignored

### Parameter "Brightness"





This parameter is for setting the brightness of the corresponding scene. Options: **0...100 %**

### Parameter "Dimming"

This parameter is for setting the dimming time of the corresponding scene. Options: **2...255 s**

### 5.3.3.2.Parameter window "Time function"

--- KNX Universal Dimming Actuator,4-Fold > Outputs setting > Channel A-... > Time function

|  |   |  |
|--|---|--|
| <div style="background-color: #e0e0e0; padding: 2px; border: 1px solid #ccc; margin-bottom: 2px;">  KNX Secure             </div> <div style="background-color: #e0e0e0; padding: 2px; border: 1px solid #ccc; margin-bottom: 2px;">  General             </div> <div style="background-color: #e0e0e0; padding: 2px; border: 1px solid #ccc;">   Outputs setting             </div> | <p>Time function</p> <p>Delay for switch on</p> <p>Delay for switch off</p> | <div style="background-color: #e0e0e0; padding: 2px; border: 1px solid #ccc; margin-bottom: 2px;">                 Delay switch  </div> <div style="display: flex; align-items: center; margin-bottom: 2px;"> <input style="width: 80%; border: 1px solid #ccc;" type="text" value="00:00:10"/> <span style="margin-left: 5px;">hh:mm:ss</span> </div> <div style="display: flex; align-items: center;"> <input style="width: 80%; border: 1px solid #ccc;" type="text" value="00:00:10"/> <span style="margin-left: 5px;">hh:mm:ss</span> </div> |
|--|---|--|

Delay switch

--- KNX Universal Dimming Actuator,4-Fold > Outputs setting > Channel A-... > Time function

|  |  |
|--|--|
| <ul style="list-style-type: none"> <li>KNX Secure</li> <li>General</li> <li>Outputs setting <ul style="list-style-type: none"> <li>Channel A-... <ul style="list-style-type: none"> <li>User defined dimming cur...</li> <li>Scene function</li> </ul> </li> </ul> </li> </ul> | <p>Time function: Flashing switch</p> <p>On time for flashing: 00:00:10 hh:mm:ss</p> <p>Off time for flashing: 00:00:10 hh:mm:ss</p> <p>Number of flashing cycles [0..10000,0=no limit]: 0</p> <p>Status after flashing: Unchange</p> <p>Control mode of flashing: Start with "1", Stop with "0"</p> |
|--|--|

Flash switch

--- KNX Universal Dimming Actuator,4-Fold > Outputs setting > Channel A-... > Time function

|   |   |
|---|---|
| <ul style="list-style-type: none"> <li>KNX Secure</li> <li>General</li> <li>Outputs setting <ul style="list-style-type: none"> <li>Channel A-... <ul style="list-style-type: none"> <li>User defined dimming cur...</li> <li>Scene function</li> <li><b>Time function</b></li> <li>Threshold function</li> <li>Forced function</li> </ul> </li> </ul> </li> </ul> | <p>Time function: Staircase lighting</p> <p>Duration time: 00:02:00 hh:mm:ss</p> <p>Time extension: Retriggerable</p> <p>Control mode of staircase lighting: Start with "1", Off with "0"</p> <p>Prewarning before staircase time end: Dim-down the dimming value and via object</p> <p>Warning time: 00:00:30 hh:mm:ss</p> <p>Value of dimming down: 20 %</p> <p>Duration time can be changed via bus: <input checked="" type="checkbox"/></p> <p><b>i</b> The duration time receiving from bus must be longer than the warning time, otherwise it will be ignored</p> |
|---|---|

Staircase lighting

Fig.5.3.3.2 "Time function" parameter window

Different configurations of time function can be used for different application.

### Parameter "Time function"

This parameter is for setting the time function, its brightness is depending on the value of switch on/off. Options:

#### Delay switch

#### Flashing switch

#### Staircase lighting

Delay switch: delay a period time to switch on/off, dimming mode is Jumping.

Flashing switch: flashing to switch on/off, dimming mode is Jumping.

Staircase lighting: dimming mode is Jumping, use the General dimming time.

---

**Note: time function will be interrupted directly after entering safety or forced operation.**

### Parameter "Delay for switch on"

### Parameter "Delay for switch off"

These two parameters are visible when "Delay switch" is selected. Set the delay time for switch on/off, execute the on/off telegram received from bus after the delay has elapsed. During delay time, receive the same telegram again, the delay time is reset.

Options: **00:00:00 ...23h:59min:59s**

### Parameter "On time for flashing"

### Parameter "Off time for flashing"

These two parameters are visible when "Flashing switch" is selected. Set the duration time of flashing for switch on/off.

Options: **00:00:05s ...23h:59min:59s**

### Parameter "Number of flashing cycles [0..10000,0=no limit]"

This parameter is visible when "Flashing switch" is selected. Set the number of flashing cycles, a cycle includes an on and an off. 0 means the cycles is no limited. Options: **0...10000**

### Parameter "Status after flashing"

This parameter is visible when "Flashing switch" is selected. Set the status after flashing. Options:

**Switching off**

**Switching on**

**Unchange**

**Note: there is a possibility of an extra half cycle of action when "Switching on" or "Switching off" is selected.**

### Parameter "Control mode of flashing"

This parameter is visible when "Flashing switch" is selected. Set the control mode of flashing.

Options:

**Start with "1", Stop with "0"**

### **Start with "0", Stop with "1"**

### **Start with "0/1", can not be stopped**

Start with "1", Stop with "0": it will start flashing with value "1" and stop flashing with "0", action to the end status when stopped, which is defined via previous parameter.

Start with "0", Stop with "1": it will start flashing with value "0" and stop flashing with "1", action to the end status when stopped, which is defined via previous parameter.

Start with "0/1", can not be stopped: it will start flashing with value "0" or "1", and can not stop until the number of the flashing cycles is exhausted, or stop via the interruption from other operation.

### **Parameter "Duration time"**

This parameter is visible when "Staircase lighting" is selected. Set the duration time of staircase lighting switch on, and switch off automatically after the time has elapsed.

Options: **00:00:05s ...23h:59min:59s**

### **Parameter "Time extension"**

This parameter is visible when "Staircase lighting" is selected. Set whether to retrigger or extend the duration time when receive an on telegram during the time. Options:

#### **Not retriggerable**

#### **Retriggerable**

#### **Extend duration time**

Not retriggerable: ignore the telegram, switch off automatically after the time has elapsed.

Retriggerable: retrigger the duration time when receive an on telegram during the time.

Extend duration time: add up a duration time to the remaining time when receive an on telegram during the duration time. For example the duration time is set as 60s, but it is still has 40s left, and receive an on telegram at the moment, then the new duration time is  $40s+60s=100s$ , and the staircase light will be turned off automatically after the 100s is elapsed. If receive multiple on telegrams continuously, the duration time will continue to add up until the maximum time is reached.

### **Parameter "Control mode of staircase lighting"**

This parameter is visible when "Staircase lighting" is selected. Set the control mode of staircase

lighting. Options:

**Start with "1", Stop with "0"**

**Start with "1", no reaction with "0"**

**Start with "0/1", can not be stopped**

**Start with "1", Off with "0"**

Start with "1", Stop with "0": it will switch on the staircase light with the value "1" and stop the timing with "0", keep the current lamps status until it is changed by other operations.

Start with "1", no reaction with "0": it will switch on the staircase lights with the value "1" and no reaction with "0".

Start with "0/1", can not be stopped: it will switch on the staircase lights with the value "1" or "0", and can not stop until the duration time is exhausted, or stop via the interruption from other operation.

Start with "1", Off with "0": it will switch on the staircase lights with the value "1" and switch off with "0"

### Parameter "Prewarning before staircase time end"

This parameter is visible when "Staircase lighting" is selected. Set whether to prewarn before staircase light time end, and set the prewarning mode. User can be noticed before the staircase light time is about to finish. Options:

**No**

**No, but dim-down the dimming value after end**

**Via object**

**Via flashing switching on-off**

**Via flashing switching on-off and object**

**Dim-down the dimming value**

**Dim-down the dimming value and via object**

No: no prewarn, and switch off automatically after the time has elapsed.

No, but dim-down the dimming value after end: no prewarn, but dim down the brightness after the time has elapsed.

Via object: prewarn via the object.

---

Via flashing switching on-off: prewarn via a short flashing, 1s to switch on and 1s to switch off, dimming mode is Jumping.

Via flashing switching on-off and object: prewarn, refer to the explanation of the previous options.

Dim-down the dimming value: prewarn via dimming down the brightness.

Dim-down the dimming value and via object: prewarn, refer to the explanation of the previous options.

### **Parameter "Warning time"**

This parameter is visible when the selection does not contains "No...". Set the time of prewarning.

Options: **00:00:05s...00h:59min:59s**

**Note: the warning time must be less than the duration time, or it cannot set on the ETS.**

**Note: the warning time is contained in the startup time of staircase lighting. If switch off before the warning time, there is no prewarning.**

### **Parameter "Value of dimming down"**

This parameter is visible when the selection contains "Dim-down the dimming value....". Set the brightness value of dimming down at the end of the staircase lighting. Options: **1...100 %**

### **Parameter "Duration time can be changed via bus"**

This parameter is visible when "Staircase lighting" is selected. Set whether the duration time can be changed via bus. Store the modified value when bus failure, recovery to the value set by parameter after download.



The duration time receiving from bus must be longer than the warning time, otherwise it will be ignored

### 5.3.3.3. Parameter window "Threshold function"

Fig.5.3.3.3 "Threshold function" parameter window

Switch on/off or dimming the brightness according to telegram from the bus and threshold set on the ETS. **Note: the brightness of threshold function is depending on the value of switch on/off.**

#### Parameter "Threshold value datatype"

This parameter is for setting the threshold value datatype. Options:

**1byte unsigned value (DPT5.010)**

**1byte percentage (DPT5.001)**

**Temperature (DPT9.001)**

**Illuminance (DPT9.004)**

#### Parameter "Threshold value 1"

#### Parameter "Threshold value 2"

These two parameters are for setting the threshold value 1 and 2. Options are display according to the threshold value datatype.

When 1byte unsigned value, options: **0...255**

When 1byte percentage, options: **0...100 %**

When Temperature, options: **-20...95 ° C**

When Illuminance, options: **0...65535 lux**

**Note: the threshold 1 must be less than threshold 2, or they cannot be set on the ETS, as shown as following:**

|                   |                                  |
|-------------------|----------------------------------|
| Threshold value 1 | <input type="text" value="200"/> |
| Threshold value 2 | <input type="text" value="200"/> |

### Parameter "Threshold value can be changed via bus"

This parameter is for setting whether the threshold 1 and 2 can be changed via bus.

Store the modified value when bus failure, recovery to the value set by parameter after download.

### Parameter "Threshold behavior"

This parameter is for setting whether the threshold 1 and 2 with hysteresis. Options:

**Without hysteresis**

**With hysteresis**

The hysteresis can avoid the unnecessary behaviour caused by the input value if the value is between two threshold values.

### Parameter "Output type"

This parameter is for setting the output type after threshold comparison. Options:

**Switching**

**Brightness value**

### If input value<=threshold value 1

Set the output value when input value is less than or equal to the threshold 1. Following parameter and its options are displayed according to the output type.

#### Parameter "Output is"

This parameter is visible when "Switching" is selected. Options:

**Switching off**

**Switching on**

**Unchange**

#### Parameter "Dimming value is"

This parameter is visible when "Brightness value" is selected. Options: **0...100 %**

### If threshold value 1 < input value < threshold value 2

Set the output value when input value is between the threshold 1 and 2. Output parameter and its options are displayed according to the output type, as above explanation.

Note: when with hysteresis, the output is only **Unchange**

### If input value >= threshold value 2

Set the output value when input value is greater than the threshold 2. Output parameter and its options are displayed according to the output type, as above explanation.

#### 5.3.3.4. Parameter window "Forced function"

--- KNX Universal Dimming Actuator,4-Fold > Outputs setting > Channel A... > Forced function

|   |   |
|---|---|
| <ul style="list-style-type: none"> <li>KNX Secure</li> <li>General</li> <li>Outputs setting</li> <li>Channel A...</li> <li>User defined dimming cur...</li> </ul> | <p>Forced operation datatype <input checked="" type="radio"/> 1bit <input type="radio"/> 2bit</p> <p>Forced operation at object value <input type="radio"/> 0=Forced/1=Cancel <input checked="" type="radio"/> 1=Forced/0=Cancel</p> <p>Behavior at forced operation Preset brightness value</p> <p>Preset brightness value 100 %</p> <p>Behavior at end of forced operation Unchange</p> |
|---|---|

1bit

--- KNX Universal Dimming Actuator,4-Fold > Outputs setting > Channel A... > Forced function

|   |   |
|---|---|
| <ul style="list-style-type: none"> <li>KNX Secure</li> <li>General</li> <li>Outputs setting</li> <li>Channel A...</li> <li>User defined dimming cur...</li> </ul> | <p>Forced operation datatype <input type="radio"/> 1bit <input checked="" type="radio"/> 2bit</p> <p>Behavior at forced operation "switch on" <input checked="" type="radio"/> Preset brightness value <input type="radio"/> Unchange</p> <p>Preset brightness value 100 %</p> <p>Behavior at forced operation "switch off" Switching off</p> <p>Behavior at end of forced operation Unchange</p> |
|---|---|

2bit

Fig.5.3.3.4 "Forced function" parameter window

The lamp can be forcibly fixed at a brightness in some special situations. Forced function has the highest priority. Ignore the normal control telegram received from bus when during in forced or safety operation.

### Parameter "Forced operation datatype"

This parameter is for setting the datatype of forced operation. Options:

**1bit**

**2bit**

### Parameter "Forced operation at object value"

This parameter is visible when 1bit. Set the object value for activating or canceling the forced.

Options:

**0=Forced/1=Cancel**

**1=Forced/0=Cancel**

### Parameter "Behavior at forced operation"

This parameter is visible when 1bit. Set behavior at forced operation. Options:

**Switching off**

**Preset brightness value**

**Unchange**

#### Parameter "Preset brightness value"

This parameter is visible when "Preset brightness value" is selected. Set the preset brightness value.

Options: **1...100 %**

### Parameter "Behavior at forced operation "switch on""

This parameter is visible when 2bit. Set the behavior at forced operation "switch on" when receive telegram value 3 from 2bit. Options:

**Preset brightness value**

**Unchange**

#### Parameter "Preset brightness value"

This parameter is visible when "Preset brightness value" is selected. Set the preset brightness value.

Options: **1...100 %**

### Parameter "Behavior at forced operation "switch off""

This parameter is visible when 2bit. Set the behavior at forced operation "switch off" when receive

telegram value 2 from 2bit. Option is only **Switching off**

### Parameter "Behavior at end of forced operation"

This parameter is for setting the behavior at end of forced operation. **Note: the telegram values 0/1 from 2bit are used to cancel forced operation.** Options:

**Switching off**

**Preset brightness value**

**Unchange**

1. When receive a telegram to end forced operation, it is valid if the forced operation has been activated before, otherwise ignore the telegram.

2. When a telegram to end forced operation is valid, if there is another priority (safety operation) active in the device, execute this action of this priority; otherwise, ignore the end telegram and execute the action of forced operation.

### Parameter "Preset brightness value"

This parameter is visible when "Preset brightness value" is selected. Set the preset brightness value.

Options: **1...100 %**

### 5.3.3.5. Parameter window "Safety function"

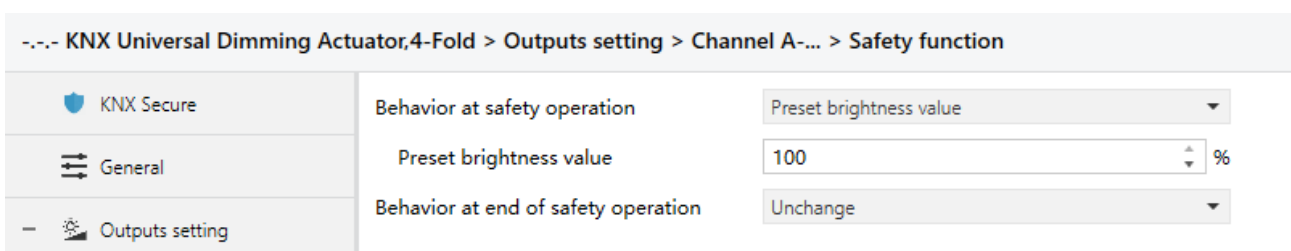

Fig.5.3.3.5 "Safety function" parameter window

Safety function can work with external sensor and perform dimming behaviour in some emergency situations. Safety function has the second highest priority and only lower than forced function.

### Parameter "Behavior at safety operation"

### Parameter "Behavior at end of safety operation"

These two parameters are for setting the behavior for activating or canceling the safety operation.

Options:

**Switching off**

**Preset brightness value**

**Unchange**

### Parameter "Preset brightness value"

This parameter is visible when "Preset brightness value" is selected. Set the preset brightness value.

Options: **1...100 %**

1. When receive an end telegram, it is valid if the safety operation has been activated before, otherwise ignore the telegram.

2. When the end telegram is valid, if there is another priority (forced operation) active in the device, execute this action of this priority; otherwise, ignore the cancel telegram and execute the action of safety operation.

### 5.3.3.6. Parameter window "Operating hours counter"

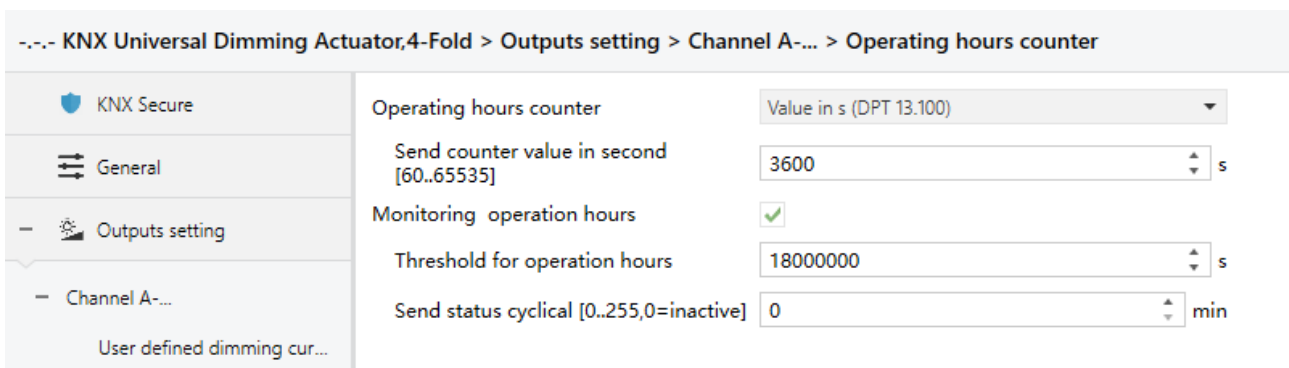

Fig.5.3.3.6 "Operating hours counter" parameter window

#### Parameter "Operating hours counter"

This parameter is for setting whether activate the function of operating hours counter, and setting the datatype. It is used to count the time that the lamp has been switched on. If brightness is greater than "0", start timing. It can be used as a seconds counter or an hours counter. Options:

**Inactive**

**Value in s (DPT 13.100)**

### Value in h (DPT 7.007)

These following parameters are visible when parameter is activated:

#### Parameter "Send counter value in second [0..65535]"

This parameter is visible when "Value in s (DPT 13.100)" is selected. Set the cycle for sending counter value. If set to 3600s, that is send a counter value to the bus every 3600s.

Options: **60...65535 s**

#### Parameter "Send counter value in hours [0..255]"

This parameter is visible when "Value in h (DPT 7.007)" is selected. Set the cycle for sending counter value. If set to 1h, that is send a counter value to the bus every hours. Options: **1...255 h**

#### Parameter "Monitoring operation hours"

This parameter is for setting whether to enable the monitoring of operating hours counter, which is used to monitor the time that the lamp has been switched on. When the time is closed to the end of the lamp's life, send a telegram to remind the user to change a new lamp.

Following parameters are visible when the monitoring is enabled:

#### Parameter "Threshold for operation hours"

This parameter is for setting the threshold for operation hours, usually refer to the lamp's life. The range of options depends on the datatype.

When "Value in s (DPT 13.100)", options: **100...2147483647 s**

When "Value in h (DPT 7.007)", options: **1...65535 h**

#### Parameter "Send status cyclical [0..255,0=inactive]"

This parameter is for setting the cycle of sending status, 0 is no send. Send on change is enabled by default. Options: **0...255 min**

### 5.4. Parameter window "Logic"

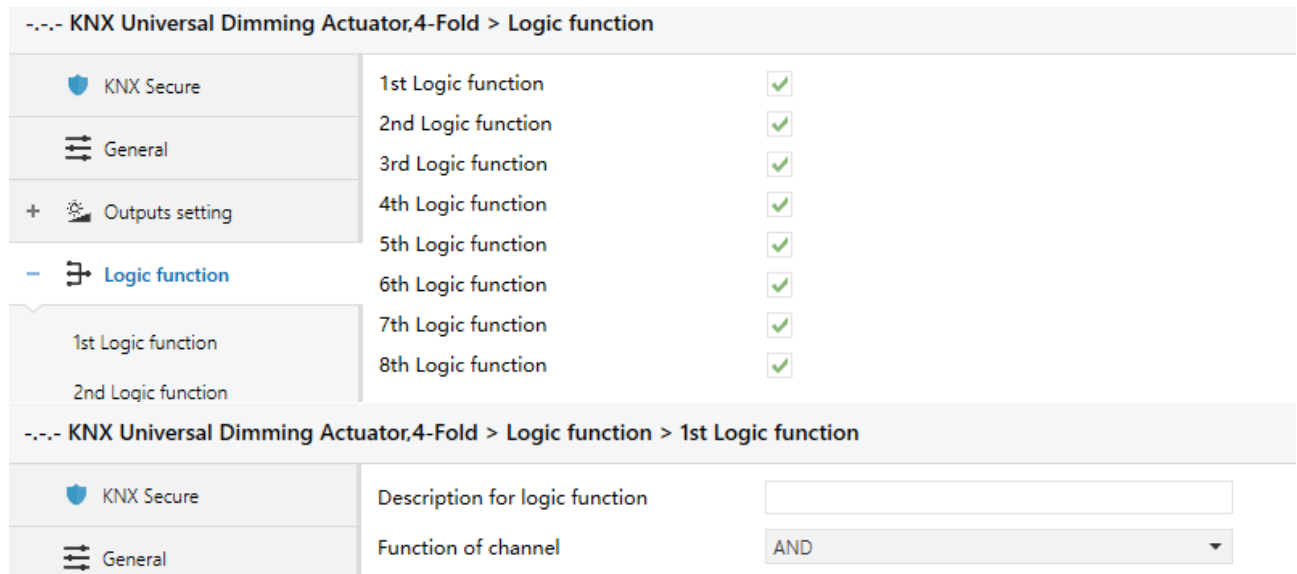

Fig.5.4 "Logic function setting" parameter window

#### Parameter "1st/2nd/3rd... Logic function"

This parameter is for setting the setting interface of logic function, display corresponding logic function page when select. Up to enable 8 logic functions.

#### Parameter "Description for logic function"

This parameter is for setting the name description for logic function, up to input 30 characters.

#### Parameter "Function of channel"

This parameter is for setting function of the channel. Options:

- AND**
- OR**
- XOR**
- Gate forwarding**
- Threshold comparator**
- Format convert**
- Gate function**
- Delay function**
- Staircase lighting**

AND/OR/XOR: as the parameter is similar to the communication object (only the logic algorithm is

different), the following parameters taking one options for example.

### 5.4.1. Parameter window "AND/OR/XOR"

--- KNX Universal Dimming Actuator,4-Fold > Logic function > 1st Logic function

|                    |  |  |
|--------------------|--|--|
| KNX Secure         | Description for logic function                     | <input type="text"/>   |
| General            | Function of channel                                | AND <input type="text"/>   |
| Outputs setting    | Input a  | Disconnected <input type="text"/>  |
| Logic function     | Default value                                      | <input checked="" type="radio"/> 0 <input type="radio"/> 1   |
|                    | Input b  | Disconnected <input type="text"/>  |
| 1st Logic function | Default value                                      | <input checked="" type="radio"/> 0 <input type="radio"/> 1   |
|                    | Input c  | Disconnected <input type="text"/>  |
| 2nd Logic function | Default value                                      | <input checked="" type="radio"/> 0 <input type="radio"/> 1   |
| 3rd Logic function | Input d  | Disconnected <input type="text"/>  |
| 4th Logic function | Default value                                      | <input checked="" type="radio"/> 0 <input type="radio"/> 1   |
| 5th Logic function | Input e  | Disconnected <input type="text"/>  |
| 6th Logic function | Default value                                      | <input checked="" type="radio"/> 0 <input type="radio"/> 1   |
| 7th Logic function | Input f  | Disconnected <input type="text"/>  |
| 8th Logic function | Default value                                      | <input checked="" type="radio"/> 0 <input type="radio"/> 1   |
|                    | Input g  | Disconnected <input type="text"/>  |
|                    | Default value                                      | <input checked="" type="radio"/> 0 <input type="radio"/> 1   |
|                    | Input h  | Disconnected <input type="text"/>  |
|                    | Default value                                      | <input checked="" type="radio"/> 0 <input type="radio"/> 1   |
|                    | Result is inverted                                 | <input checked="" type="radio"/> No <input type="radio"/> Yes  |
|                    | Read input object value after bus voltage recovery | <input checked="" type="radio"/> No <input type="radio"/> Yes  |
|                    | Output send when                                   | <input checked="" type="radio"/> Receiving a new telegram<br><input type="radio"/> Every change of output object |
|                    | Send delay time: Base                              | None <input type="text"/>  |
|                    | Factor: 1..255                                     | 1 <input type="text"/>   |

Fig.5.4.1 "AND/OR/XOR" parameter window

#### Parameter "Input a/b/c/d/e/f/g//h"

This parameter is for setting whether input x to calculate, whether to normally calculate or inverted calculate. Options:

**Disconnected**

### Normal

### Inverted

Disconnected: not to calculate;

Normal: to directly calculate the input value;

Inverted: invert the input value, then to calculate. **Note: not to invert the initiate value.**

### Parameter "Default value"

This parameter is for setting the initial value of logic input x. Options:

0

1

### Parameter "Result is inverted"

This parameter is for setting whether to invert the logic calculation result. Options:

No

Yes

No: output directly;

Yes: output after inverting.

### Parameter "Read input object value after voltage recovery"

This parameter is for setting whether to send the read request to the logic input object after device voltage recovery or finish programming. Options:

No

Yes

### Parameter "Output send when"

This parameter is for setting the condition of sending logic result. Options:

**Receiving a new telegram**

**Every change of output object**

Receiving a new telegram: every time the object received a new input value will the logic result be sent to the bus;

Every change of output object: only when logic result has changed will it be sent to the bus.

**Tip: when in the first time to logic calculate, the logic result will be sent even if it has no change.**

### Parameter "Send delay time"

|                |               |
|----------------|---------------|
| <b>Base:</b>   | <b>None</b>   |
|                | <b>0.1s</b>   |
|                | <b>1s</b>     |
|                | ...           |
|                | <b>10s</b>    |
|                | <b>25s</b>    |
| <b>Factor:</b> | <b>1..255</b> |

This parameter is for setting the delay time for sending the logic calculation result to the bus. Delay time = Base × Factor, if option "None" of Base is selected, then there is no delay.

### 5.4.2. Parameter window "Gate forwarding"

--- KNX Universal Dimming Actuator,4-Fold > Logic function > 1st Logic function

|   |  |   |
|---|--|---|
| <ul style="list-style-type: none"> <li>KNX Secure</li> <li>General</li> <li>Outputs setting</li> <li>Logic function           <ul style="list-style-type: none"> <li><b>1st Logic function</b></li> <li>2nd Logic function</li> <li>3rd Logic function</li> <li>4th Logic function</li> <li>5th Logic function</li> <li>6th Logic function</li> <li>7th Logic function</li> <li>8th Logic function</li> </ul> </li> </ul> | <p>Description for logic function</p> <p>Function of channel</p> <p>Object type of Input/Output</p> <p>Default scene NO. of Gate after startup [1~64,0=inactive]</p> <p>1-&gt;Gate trigger scene NO. is [1~64,0=inactive]</p> <p>Input A send on</p> <p>Input B send on</p> <p>Input C send on</p> <p>Input D send on</p> <p>2-&gt;Gate trigger scene NO. is [1~64,0=inactive]</p> <p>Input A send on</p> <p>Input B send on</p> <p>Input C send on</p> <p>Input D send on</p> | <input type="text"/><br>Gate forwarding<br>1bit<br><input type="text" value="0"/><br><input type="text" value="0"/><br>Output A<br>Output B<br>Output C<br>Output D<br><input type="text" value="0"/><br>Output A<br>Output B<br>Output C<br>Output D |
|---|--|---|

Fig.5.4.2 "Gate forwarding" parameter window

### Parameter "Object type of Input/Output"

This parameter is for setting the object type of input/output. Options:

**1bit**

4bit

1byte

### Parameter "Default scene NO. of Gate after startup [1~64,0=inactive]"

This parameter is for setting the initial scene where logical gate forwarding can be performed by default after device starts, which needs to be configured in the parameters. Options: **1..64, 0=inactive**

**Note: gate scene is recommended to be selected before operating, or it will enable the initiate scene by default.**

### Parameter "z->Gate trigger scene NO. is [1~64,0=inactive]"(z=1~8)

This parameter is for setting scene number of logic gate forwarding. Up to 8 trigger scene number can be set for each logic. Options: **1..64, 0=inactive**

### ——Parameter "Input A/B/C/D send on"

This parameter is for setting the output of input X (X=A/B/C/D) after gate forwarding. Options:

**Disable**

**Output A**

**Output B**

...

**Output B,C,D**

According to the options, one input can be forwarded into one or more outputs, the output value is the same as the input value.

### 5.4.3. Parameter window "Threshold comparator"

--- KNX Universal Dimming Actuator,4-Fold > Logic function > 1st Logic function

|   |  |  |
|---|--|--|
| <ul style="list-style-type: none"> <li>KNX Secure</li> <li>General</li> <li>Outputs setting</li> <li>Logic function             <ul style="list-style-type: none"> <li><b>1st Logic function</b></li> <li>2nd Logic function</li> <li>3rd Logic function</li> <li>4th Logic function</li> <li>5th Logic function</li> <li>6th Logic function</li> <li>7th Logic function</li> <li>8th Logic function</li> </ul> </li> </ul> | <p>Description for logic function</p> <p>Function of channel</p> <p>Threshold value data type</p> <p>Threshold value</p> <p>If Object value&lt;Threshold value</p> <p>If Object value=Threshold value</p> <p>If Object value!=Threshold value</p> <p>If Object value&gt;Threshold value</p> <p>If Object value&lt;=Threshold value</p> <p>If Object value&gt;=Threshold value</p> <p>Output send when</p> <p>Send delay time: Base</p> <p>Factor: 1..255</p> | <p></p> <p>Threshold comparator</p> <p>1byte unsigned value (DPT5.010)</p> <p>0</p> <p>Do not send telegram</p> <p>Do not send telegram</p> <p>Do not send telegram</p> <p>Do not send telegram</p> <p>Do not send telegram</p> <p>Do not send telegram</p> <p> <input checked="" type="radio"/> Receiving a new telegram<br/> <input type="radio"/> Every change of output object         </p> <p>None</p> <p>1</p> |
|---|--|--|

Fig.5.4.3 "Threshold comparator" parameter window

#### Parameter "Threshold value data type"

This parameter is for setting the threshold value data type. Options:

- |  |  |
|--|--|
| <b>4bit value (DPT3.007)</b>           | <b>4byte unsigned value[0..4294967295]</b> |
| <b>1byte unsigned value (DPT5.010)</b> | <b>Ext. temperature value (DPT 9.001)</b>  |
| <b>2byte unsigned value (DPT7.001)</b> | <b>Ext. humidity value (DPT 9.007)</b>     |
| <b>2byte signed value (DPT8.x)</b>     | <b>Illuminance value (DPT 9.004)</b>       |
| <b>2byte float value (DPT9.x)</b>      |  |

#### Parameter "Threshold value "

This parameter is for setting threshold value, the range depends on the data type. Options:

- 4bit value (DPT3.007) 0..15 / 1byte unsigned value (DPT5.010) 0..255 /**  
**2byte unsigned value (DPT7.001) 0..65535 / 2byte signed value (DPT8.x) -32768..32767 /**  
**2byte float value (DPT9.x) -670760...670760 / 4byte unsigned value[0..4294967295]**  
**0..4294967295 / Ext. temperature value (DPT 9.001) -20..95°C / Ext. humidity value (DPT 9.007)**  
**0..100% / Illuminance value (DPT 9.004) 0..65535lux**

### Parameter "Hysteresis threshold value"

This parameter is visible when object datatype is selected "2byte float value (DPT9.x)", "Illuminance value (DPT 9.004)". Set the hysteresis threshold value. Options: **0..500**

### Parameter "If Object value<Threshold value"

**Parameter "If Object value=Threshold value"**

**Parameter "If Object value!=Threshold value"**

**Parameter "If Object value>Threshold value"**

**Parameter "If Object value<=Threshold value"**

**Parameter "If Object value>=Threshold value"**

This parameter is for setting the logic result value that should be sent when threshold value Less than, equal to, not equal to, greater than, less than or equal to the setting valve. When object datatype is selected "2byte float value (DPT9.x)", can only set the object value less than or greater than threshold value. Options:

**Do not send telegram**

**Send value "0"**

**Send value "1"**

Do not send telegram: not consider to select this option;

Send value "0"/"1": when condition is satisfied, send telegram 0 or1.

If there is a conflict between the setting options between parameters, the base on the value that should be sent when reach the final parameter condition. **For example: parameter "If Object value=Threshold value" is set to be "Send value "0" "; parameter "If Object value<=Threshold value" is set to be "Send value "1" "; when object value is equal to the threshold value, then the logic result will send "1".**

### Parameter "Output send when"

This parameter is for setting the condition of sending logic result. Options:

**Receiving a new telegram**

**Every change of output object**

Receiving a new telegram: every time the object received a new input value will the logic result be

sent to the bus;

Every change of output object: only when logic result has changed will it be sent to the bus.

**Tip: when in the first time to logic algorithm, the logic result will be sent even if it has no change.**

### Parameter "Send delay time"

|                |               |
|----------------|---------------|
| <b>Base:</b>   | <b>None</b>   |
|                | <b>0.1s</b>   |
|                | <b>1s</b>     |
|                | <b>...</b>    |
|                | <b>10s</b>    |
|                | <b>25s</b>    |
| <b>Factor:</b> | <b>1..255</b> |

This parameter is for setting the delay time for sending the logic algorithm result to the bus. Delay time = Base x Factor, if option "None" of Base is selected, then there is no delay.

### 5.4.4. Parameter window "Format convert"

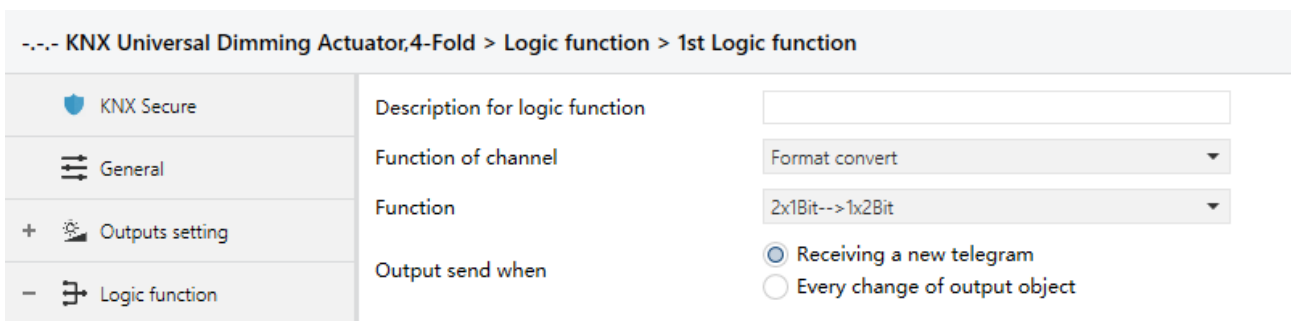

Fig.5.4.4 "Format convert" parameter window

### Parameter "Function"

This parameter is for setting the format convert type. Options:

**2x1bit-->1x2bit**

**8x1bit-->1x1byte**

**1x1byte-->1x2byte**

**2x1byte-->1x2byte**

**2x2byte-->1x4byte**

1x1byte-->8x1bit

1x2byte-->2x1byte

1x4byte-->2x2byte

1x3byte-->3x1byte

3x1byte-->1x3byte

### Parameter "Output send when"

This parameter is for setting the condition of sending logic result. Options:

**Receiving a new telegram**

**Every change of output object**

Receiving a new telegram: every time the object received a new input value will the logic result be sent to the bus;

Every change of output object: only when logic result has changed will it be sent to the bus.

**Tip: when in the first time to logic algorithm, the logic result will be sent even if it has no change.**

### 5.4.5. Parameter window "Gate function"

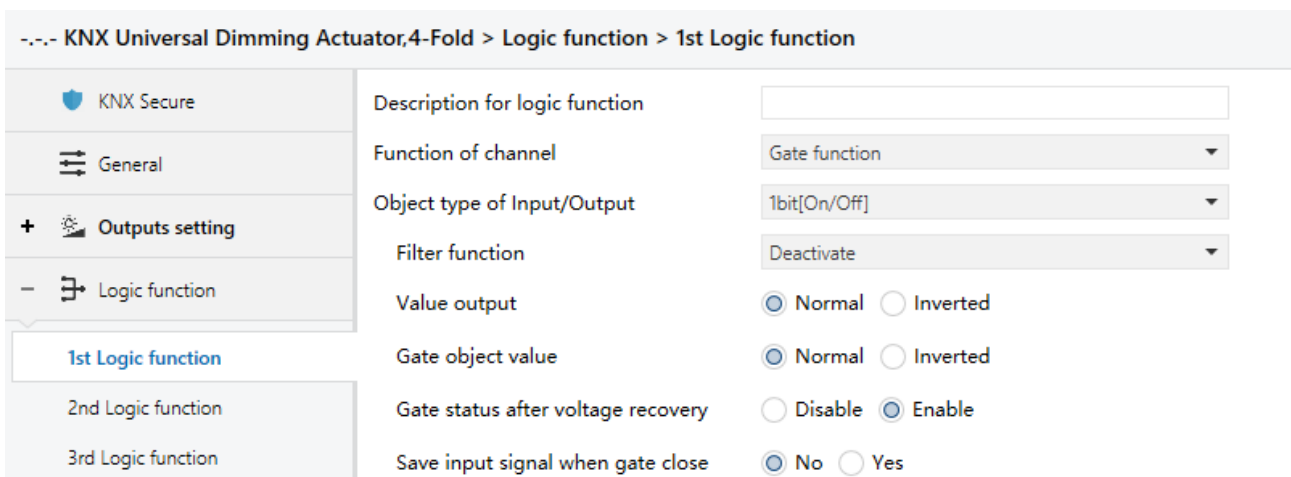

Fig.5.4.5 "Gate function" parameter window

### Parameter "Object type of Input/Output"

This parameter is for setting the object type of input/output. Options:

**1bit[On/Off]**

**1byte[0..100%]**

**1byte[0..255]**

**2byte[Float]**

**2byte[0..65535]**

### Parameter "Filter function"

This parameter is visible when "1bit[On/Off]" is selected. Set whether to filter On or Off telegram, only pass one of them or pass all. Options:

**Deactivate**

**On filter out**

**Off filter out**

Deactivate: Do not filter the On or Off telegrams;

On filter out: Off can pass, On cannot pass;

Off filter out: On can pass, Off cannot pass.

### Parameter "Value output"

This parameter is visible when "1bit[On/Off]" is selected. Set whether to invert the value then output it. Options:

**Normal**

**Inverted**

### Parameter "Gate object value"

This parameter is for setting whether to invert the gate object value then output it. Options:

**Normal**

**Inverted**

### Parameter "Gate status after voltage recovery"

This parameter is for setting the gate status after power on. Options:

**Disable**

**Enable**

### Parameter "Save input signal when gate close"

This parameter is for setting whether to save input signal on gate close. Options:

**No**

**Yes**

No: disable to save the input, the input values received during the gate closing period are ignored;

Yes: enable to save the input, the input values received during the gate closing period are output when gate is open (whether the input value is changed or not).

### 5.4.6. Parameter window "Delay function"

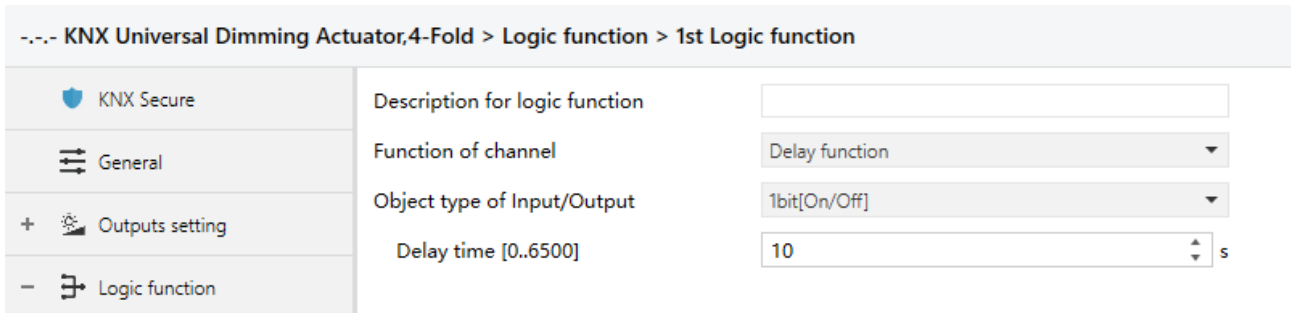

Fig.5.4.6 "Delay function" parameter window

#### Parameter "Object type of Input/Output"

This parameter is for setting the object type of input/output. Options:

**1bit[On/Off]**

**1byte[0..100%]**

**1byte[0..255]**

**2byte[Float]**

**2byte[0..65535]**

#### Parameter "Delay time [0..6500]"

This parameter is for setting the delay time that output object forwards the value when the input object receives the telegram. Options: **0..6500 s**

**Note: Receive telegram again in delay time, re-timing.**

### 5.4.7. Parameter window "Staircase lighting"

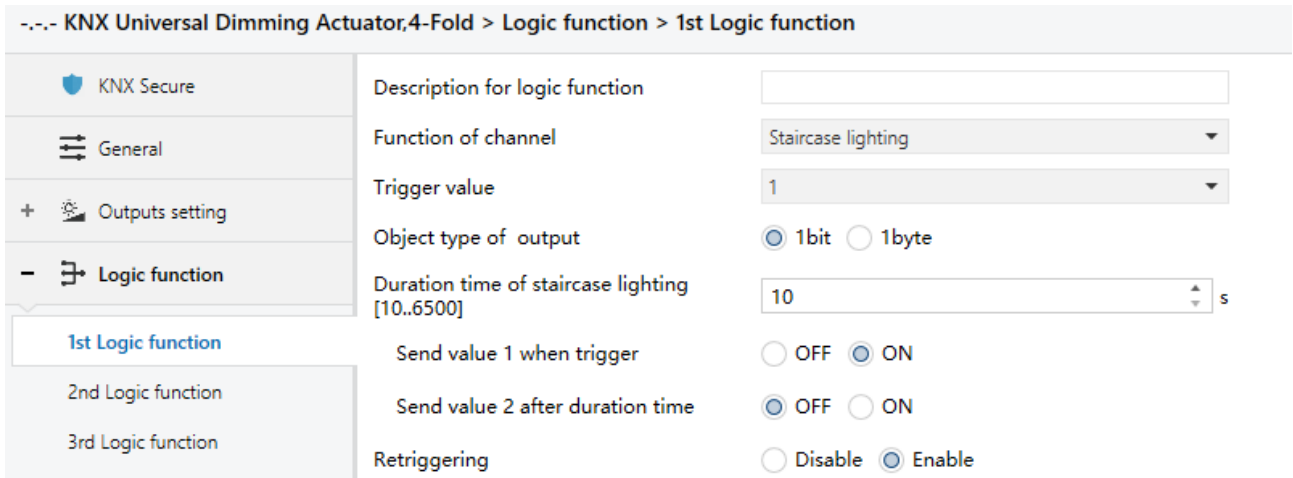

Fig.5.4.7 "Staircase lighting" parameter window

#### Parameter "Trigger value"

This parameter is for setting the telegram value of the object "Trigger value". Options:

**0**

**1**

**0 or 1**

#### Parameter "Object type of output"

This parameter is for setting the object type of output. Options:

**1bit**

**1byte**

#### Parameter "Duration time of staircase lighting[10..6500]"

This parameter is for setting duration time of staircase lighting after the stair light power on.

Options: **10..6500 s**

#### Parameter "Send value 1 when trigger"

#### Parameter "Send value 2 after duration time"

These parameters are for setting the value to send. Send value 1 when trigger, and then send value 2 after duration time. Options display according to the output object datatype.

When 1 bit, options:

**OFF**

### ON

When 1 byte , options: **0..255**

### Parameter "Retriggering"

This parameter is for setting whether to trigger re-timing when received trigger value in delay time.

Options:

**Disable**

**Enable**

### Chapter 6 Description of Communication Object

The communication object is the medium to communicate other device on the bus, namely only the communication object can communicate with the bus.

**NOTE:** "C" in "Flag" column in the below table means enable the communication function of the object; "W" means value of object can be written from the bus; "R" means the value of the object can be read by the other devices; "T" means the object has the transmission function; "U" means the value of the object can be updated.

#### 6.1."General" Communication Object

|   | Number | Name    | Object Function           | Description | Group Address | Length | C | R | W | T | U | Data Type            | Priority |
|---|--------|---------|---------------------------|-------------|---------------|--------|---|---|---|---|---|----------------------|----------|
| ■ | 1      | General | In operation              |             |               | 1 bit  | C | - | - | T | - | switch               | Low      |
| ■ | 2      | General | Central: Switching        |             |               | 1 bit  | C | - | W | - | - | switch               | Low      |
| ■ | 3      | General | Central: Relative dimming |             |               | 4 bit  | C | - | W | - | - | dimming control      | Low      |
| ■ | 4      | General | Central: Absolute dimming |             |               | 1 byte | C | - | W | - | - | percentage (0..100%) | Low      |
| ■ | 5      | General | Central: Safety           |             |               | 1 bit  | C | - | W | - | - | alarm                | Low      |

Fig.6.1 "General" communication object

| NO.   | Object Function                  | Name           | Data Type    | Flag         | DPT                     |
|---|----------------------------------|----------------|--------------|--------------|-------------------------|
| 1   | <b>In operation</b>              | <b>General</b> | <b>1bit</b>  | <b>C,R,T</b> | <b>1.001 switch</b>     |
| The communication object is used to periodically send a telegram "1" to the bus to indicate that the device is working properly.  |                                  |                |              |              |                         |
| 2   | <b>Central: Switching</b>        | <b>General</b> | <b>1bit</b>  | <b>C,W</b>   | <b>1.001 switch</b>     |
| The communication object is used to receive a command of switching on/off lamps for central control, it only applies to the channel that the central control is enabled.                  |                                  |                |              |              |                         |
| 3   | <b>Central: Relative dimming</b> | <b>General</b> | <b>4bit</b>  | <b>C,W</b>   | <b>3.007 dimming</b>    |
| The communication object is used to receive a command of relative dimming for central control, to dim up or dim down. It only applies to the channel that the central control is enabled. |                                  |                |              |              |                         |
| 4   | <b>Central: Absolute dimming</b> | <b>General</b> | <b>1byte</b> | <b>C,W</b>   | <b>5.001 percentage</b> |
| The communication object is used to receive a command of absolute dimming for central control, it only applies to the channel that the central control is enabled.                        |                                  |                |              |              |                         |
| 5   | <b>Central: Safety</b>           | <b>General</b> | <b>1bit</b>  | <b>C,W</b>   | <b>1.005 alarm</b>      |
| The communication object is used to receive the 1bit telegram that is sent from other device (such as sensor, controller, etc.), the cancel telegram value is decided by the parameter.   |                                  |                |              |              |                         |

If no corresponding telegram is received within the monitoring time, it is assumed that other devices are failure, and the channel with a safety function activates the safety operation. With a monitoring time of 0, it is also possible to activate and exit the safety operation by receiving the corresponding value with this object.

In the case that the safety operation is not active, the cancel telegram is meaningless and it will be ignored.

Table 6.1 "General" communication object table

### 6.2."Output setting" Communication Object

| Number | Name          | Object Function                            | Description | Group Address | Length  | C | R | W | T | U | Data Type               | Priority |
|--------|---------------|--|-------------|---------------|---------|---|---|---|---|---|-------------------------|----------|
| 78     | Channel A-... | Switching                                  |             |               | 1 bit   | C | - | W | - | - | switch                  | Low      |
| 79     | Channel A-... | Relative dimming                           |             |               | 4 bit   | C | - | W | - | - | dimming control         | Low      |
| 80     | Channel A-... | Absolute dimming                           |             |               | 1 byte  | C | - | W | - | - | percentage (0..100%)    | Low      |
| 81     | Channel A-... | Switching, status                          |             |               | 1 bit   | C | R | - | T | - | switch                  | Low      |
| 82     | Channel A-... | Brightness value, status                   |             |               | 1 byte  | C | R | - | T | - | percentage (0..100%)    | Low      |
| 83     | Channel A-... | Short-circuit, status                      |             |               | 1 bit   | C | R | - | T | - | alarm                   | Low      |
| 84     | Channel A-... | Over-voltage, status                       |             |               | 1 bit   | C | R | - | T | - | alarm                   | Low      |
| 85     | Channel A-... | Over-temperature, status                   |             |               | 1 bit   | C | R | - | T | - | alarm                   | Low      |
| 87     | Channel A-... | Operation voltage failure                  |             |               | 1 bit   | C | R | - | T | - | alarm                   | Low      |
| 88     | Channel A-... | Scene                                      |             |               | 1 byte  | C | - | W | - | - | scene control           | Low      |
| 89     | Channel A-... | Staircase lighting                         |             |               | 1 bit   | C | - | W | - | - | start/stop              | Low      |
| 90     | Channel A-... | Duration of staircase lighting (5..65535s) |             |               | 2 bytes | C | R | W | - | - | time (s)                | Low      |
| 91     | Channel A-... | Staircase lighting Prewarning              |             |               | 1 bit   | C | R | - | T | - | alarm                   | Low      |
| 92     | Channel A-... | Threshold input                            |             |               | 1 byte  | C | - | W | - | - | counter pulses (0..255) | Low      |
| 93     | Channel A-... | Threshold value 1                          |             |               | 1 byte  | C | R | W | - | - | counter pulses (0..255) | Low      |
| 94     | Channel A-... | Threshold value 2                          |             |               | 1 byte  | C | R | W | - | - | counter pulses (0..255) | Low      |
| 95     | Channel A-... | Forced operation                           |             |               | 2 bit   | C | - | W | - | - | switch control          | Low      |

Fig.6.2 "Output setting" communication object

| NO.  | Object Function  | Name              | Data Type | Flag | DPT           |
|--|------------------|-------------------|-----------|------|---------------|
| 78   | Switching        | Channel A-{{...}} | 1bit      | C,W  | 1.001 switch  |
| <p>The communication object is used to receive a command of switching on/off lamps. Telegrams:</p> <p style="text-align: center;">1——Switch on<br/>0——Switch off</p> <p>The name in parentheses changes with the parameter "Description (max 30char.)". If description is empty, display "Channel A - ..." by default. The same below.</p> |                  |                   |           |      |               |
| 79   | Relative dimming | Channel A-{{...}} | 4bit      | C,W  | 3.007 dimming |
| <p>The communication object is used to receive a command of relative dimming, to dim up or dim down.</p> <p>Dimming down when telegram is 1~7, and the larger this range the adjust step is smaller. That is,</p>  |                  |                   |           |      |               |

|   |                                  |                          |              |              |                         |
|---|----------------------------------|--------------------------|--------------|--------------|-------------------------|
| <p>the maximum step of dimming down when is 1, and the minimum step of dimming down when is 7, stop dimming when is 0;</p> <p>Dimming up when telegram is 9~15, and the larger this range the adjust step is smaller. That is, the maximum step of dimming up when is 9, and the minimum step of dimming up when is 15, stop dimming when is 8.</p> |                                  |                          |              |              |                         |
| <b>80</b>   | <b>Absolute dimming</b>          | <b>Channel A-{{...}}</b> | <b>1byte</b> | <b>C,W</b>   | <b>5.001 percentage</b> |
| <p>The communication object is used to receive a command of absolute dimming.</p> <p>Telegrams: 0...100%</p>  |                                  |                          |              |              |                         |
| <b>81</b>   | <b>Switching, status</b>         | <b>Channel A-{{...}}</b> | <b>1bit</b>  | <b>C,R,T</b> | <b>1.001 switch</b>     |
| <p>The communication object is used to report the status of the current switch to the bus. Send "1" to the bus when the value of the brightness is larger than 0, send "0" to the bus with value of "0". <i>Send the status when voltage recovery.</i></p>  |                                  |                          |              |              |                         |
| <b>82</b>   | <b>Brightness value, status</b>  | <b>Channel A-{{...}}</b> | <b>1byte</b> | <b>C,R,T</b> | <b>5.001 percentage</b> |
| <p>The communication object is used to report the status of the current brightness value to the bus. <i>Send the status at power-up when voltage recovery.</i></p>  |                                  |                          |              |              |                         |
| <b>83</b>   | <b>Short-circuit, status</b>     | <b>Channel A-{{...}}</b> | <b>1bit</b>  | <b>C,R,T</b> | <b>1.005 alarm</b>      |
| <p>The communication object is used to report the status of short circuit to the bus. <i>Send the status at power-up when voltage recovery.</i> Telegrams:</p> <p style="padding-left: 40px;">1——Short circuit</p> <p style="padding-left: 40px;">0——Normal</p>   |                                  |                          |              |              |                         |
| <b>84</b>   | <b>Over-voltage, status</b>      | <b>Channel A-{{...}}</b> | <b>1bit</b>  | <b>C,R,T</b> | <b>1.005 alarm</b>      |
| <p>The communication object is used to report the status of over-voltage to the bus. <i>Send the status when voltage recovery.</i> Telegrams:</p> <p style="padding-left: 40px;">1——Over voltage</p> <p style="padding-left: 40px;">0——Normal</p>   |                                  |                          |              |              |                         |
| <b>85</b>   | <b>Over-temperature, status</b>  | <b>Channel A-{{...}}</b> | <b>1bit</b>  | <b>C,R,T</b> | <b>1.005 alarm</b>      |
| <p>The communication object is used to report the status of over-temperature to the bus. <i>Send the status when voltage recovery.</i> Telegrams:</p> <p style="padding-left: 40px;">1——Over temperature</p> <p style="padding-left: 40px;">0——Normal</p>   |                                  |                          |              |              |                         |
| <b>87</b>   | <b>Operation voltage failure</b> | <b>Channel A-{{...}}</b> | <b>1bit</b>  | <b>C,R,T</b> | <b>1.005 alarm</b>      |
| <p>The communication object is used to report the status of operation voltage failure to the bus. Operation voltage is failure when no valid over-zero signal is detected. <i>Send the status when voltage recovery.</i> Telegrams:</p>   |                                  |                          |              |              |                         |

| <p>1——Operation voltage failure<br/>0——Normal</p>  |   |                          |              |              |                             |                      |             |   |                |   |                |   |                |     |     |    |                 |     |               |     |               |     |               |     |     |     |                |
|--|---|--------------------------|--------------|--------------|-----------------------------|----------------------|-------------|---|----------------|---|----------------|---|----------------|-----|-----|----|-----------------|-----|---------------|-----|---------------|-----|---------------|-----|-----|-----|----------------|
| <b>88</b>  | <b>Scene</b>  | <b>Channel A-{{...}}</b> | <b>1byte</b> | <b>C,W</b>   | <b>18.001 scene control</b> |                      |             |   |                |   |                |   |                |     |     |    |                 |     |               |     |               |     |               |     |     |     |                |
| <p>The communication object is used to receive a 8 bit command to recall or storage scene. Detailed 8bit the meaning of the directive.</p> <p>Set up a 8bit Orders for the (Binary code): FXNNNNNN</p> <p style="padding-left: 40px;">F: '0' recall scene; '1' for storage scene;<br/>X : 0 ;<br/>NNNNNN: Scene number( 0... 63).</p> <p>As follows:</p> <table border="1" style="margin-left: auto; margin-right: auto;"> <thead> <tr> <th>Object message value</th> <th>Description</th> </tr> </thead> <tbody> <tr> <td>0</td> <td>Recall scene 1</td> </tr> <tr> <td>1</td> <td>Recall scene 2</td> </tr> <tr> <td>2</td> <td>Recall scene 3</td> </tr> <tr> <td>...</td> <td>...</td> </tr> <tr> <td>63</td> <td>Recall scene 64</td> </tr> <tr> <td>128</td> <td>Store scene 1</td> </tr> <tr> <td>129</td> <td>Store scene 2</td> </tr> <tr> <td>130</td> <td>Store scene 3</td> </tr> <tr> <td>...</td> <td>...</td> </tr> <tr> <td>191</td> <td>Store scene 64</td> </tr> </tbody> </table> <p>Parameter setting Options are 1~64, actually communication object "Scene" corresponds to the telegram received is 0~63. Such as parameter settings is the scene 1, communication object "Scene" sends the scene for 0.</p> |   |                          |              |              |                             | Object message value | Description | 0 | Recall scene 1 | 1 | Recall scene 2 | 2 | Recall scene 3 | ... | ... | 63 | Recall scene 64 | 128 | Store scene 1 | 129 | Store scene 2 | 130 | Store scene 3 | ... | ... | 191 | Store scene 64 |
| Object message value   | Description   |                          |              |              |                             |                      |             |   |                |   |                |   |                |     |     |    |                 |     |               |     |               |     |               |     |     |     |                |
| 0  | Recall scene 1  |                          |              |              |                             |                      |             |   |                |   |                |   |                |     |     |    |                 |     |               |     |               |     |               |     |     |     |                |
| 1  | Recall scene 2  |                          |              |              |                             |                      |             |   |                |   |                |   |                |     |     |    |                 |     |               |     |               |     |               |     |     |     |                |
| 2  | Recall scene 3  |                          |              |              |                             |                      |             |   |                |   |                |   |                |     |     |    |                 |     |               |     |               |     |               |     |     |     |                |
| ...  | ...   |                          |              |              |                             |                      |             |   |                |   |                |   |                |     |     |    |                 |     |               |     |               |     |               |     |     |     |                |
| 63   | Recall scene 64                                       |                          |              |              |                             |                      |             |   |                |   |                |   |                |     |     |    |                 |     |               |     |               |     |               |     |     |     |                |
| 128  | Store scene 1   |                          |              |              |                             |                      |             |   |                |   |                |   |                |     |     |    |                 |     |               |     |               |     |               |     |     |     |                |
| 129  | Store scene 2   |                          |              |              |                             |                      |             |   |                |   |                |   |                |     |     |    |                 |     |               |     |               |     |               |     |     |     |                |
| 130  | Store scene 3   |                          |              |              |                             |                      |             |   |                |   |                |   |                |     |     |    |                 |     |               |     |               |     |               |     |     |     |                |
| ...  | ...   |                          |              |              |                             |                      |             |   |                |   |                |   |                |     |     |    |                 |     |               |     |               |     |               |     |     |     |                |
| 191  | Store scene 64  |                          |              |              |                             |                      |             |   |                |   |                |   |                |     |     |    |                 |     |               |     |               |     |               |     |     |     |                |
| <b>89</b>  | <b>Delay switch</b>                                   | <b>Channel A-{{...}}</b> | <b>1bit</b>  | <b>C,W</b>   | <b>1.001 switch</b>         |                      |             |   |                |   |                |   |                |     |     |    |                 |     |               |     |               |     |               |     |     |     |                |
| <p>The communication object is visible when "Delay Switch" is selected for time function, used to turn on the function of delay switch.</p>  |   |                          |              |              |                             |                      |             |   |                |   |                |   |                |     |     |    |                 |     |               |     |               |     |               |     |     |     |                |
| <b>89</b>  | <b>Flashing switch</b>                                | <b>Channel A-{{...}}</b> | <b>1bit</b>  | <b>C,W</b>   | <b>1.010 start/stop</b>     |                      |             |   |                |   |                |   |                |     |     |    |                 |     |               |     |               |     |               |     |     |     |                |
| <p>The communication object is visible when "Flashing Switch" is selected for time function, used to turn on the function of flashing switch.</p>  |   |                          |              |              |                             |                      |             |   |                |   |                |   |                |     |     |    |                 |     |               |     |               |     |               |     |     |     |                |
| <b>89</b>  | <b>Staircase lighting</b>                             | <b>Channel A-{{...}}</b> | <b>1bit</b>  | <b>C,W</b>   | <b>1.010 start/stop</b>     |                      |             |   |                |   |                |   |                |     |     |    |                 |     |               |     |               |     |               |     |     |     |                |
| <p>The communication object is visible when "Staircase lighting" is selected for time function, used to turn on the function of staircase lighting.</p>  |   |                          |              |              |                             |                      |             |   |                |   |                |   |                |     |     |    |                 |     |               |     |               |     |               |     |     |     |                |
| <b>90</b>  | <b>Duration of staircase lighting<br/>(5..65535s)</b> | <b>Channel A-{{...}}</b> | <b>2byte</b> | <b>C,W,R</b> | <b>7.005time(s)</b>         |                      |             |   |                |   |                |   |                |     |     |    |                 |     |               |     |               |     |               |     |     |     |                |
| <p>The communication object is visible when "Staircase lighting" is selected for time function and</p>   |   |                          |              |              |                             |                      |             |   |                |   |                |   |                |     |     |    |                 |     |               |     |               |     |               |     |     |     |                |

|   |                               |                   |                |       |   |
|---|-------------------------------|-------------------|----------------|-------|---|
| duration time can be changed via bus. Used to modify the time, and save it after voltage failure. If the duration has not been modified, the value read from the object is the setting value of ETS parameter.  |                               |                   |                |       |   |
| 91  | Staircase lighting Prewarning | Channel A-{{...}} | 1bit           | C,R,T | 1.005 alarm   |
| <p>The communication object is visible when "Staircase lighting" is selected for time function and prewarn via bus. Used to send the telegram of prewarning before staircase lighting end. Telegram:</p> <p>1——Warning</p> <p>0——End of warning</p>   |                               |                   |                |       |   |
| 92  | Threshold input               | Channel A-{{...}} | 1byte<br>2byte | C,W   | 5.010 counter pulses(0..255)<br>5.001 percentage<br>9.001 temperature<br>9.004 brightness (lux) |
| The communication object is receive the input value of threshold function. Telegram value is determined by the datatype, and the datatype is determined by the parameter setting.   |                               |                   |                |       |   |
| 93  | Threshold value 1             | Channel A-{{...}} | 1byte<br>2byte | C,W,R | 5.010 counter pulses(0..255)<br>5.001 percentage<br>9.001 temperature<br>9.004 brightness (lux) |
| 94  | Threshold value 2             | Channel A-{{...}} | 1byte<br>2byte | C,W,R | 5.010 counter pulses(0..255)<br>5.001 percentage<br>9.001 temperature<br>9.004 brightness (lux) |
| <p>These two communication objects are visible when the threshold value 1/2 can be changed via bus. Used to modify the values, and save them after voltage failure. If the thresholds have not been modified, the value read from the object is the setting value of ETS parameter. <b>Note: threshold value 1 must be less than threshold value 2, or ignore the telegram.</b></p>   |                               |                   |                |       |   |
| 95  | Forced operation              | Channel A-{{...}} | 1bit<br>2bit   | C,W   | 1.003 enable<br>2.001 DPT_Switch control  |
| <p>The communication object is used to trigger a forced operation. Save the trigger status when voltage failure, and keep the status at voltage recovery.</p> <p>When 1bit, activate the forced operation when receive telegram 1, at this time, ignore all the other actions; End the forced operation when receive telegram 0, and the behaviour in forced operation is defined by parameter.</p> <p>When 2bit, force to switch off when receive telegram 3; force to switch on when receive telegram 2; End the forced operation when receive telegram 1 or 0.</p> |                               |                   |                |       |   |

|  |                                      |                          |                              |                |   |
|--|--------------------------------------|--------------------------|------------------------------|----------------|---|
| The end telegram is invalid when the forced operation is not active, and ignore it directly.   |                                      |                          |                              |                |   |
| <b>103</b>   | <b>Operating hours counter</b>       | <b>Channel A-{{...}}</b> | <b>2byte</b><br><b>4byte</b> | <b>C,R,W,T</b> | <b>7.007 time (h)</b><br><b>13.100 time lag (s)</b> |
| The communication object is used to send the accumulated operating time that the lamp has been switched on to the bus, begin to count when brightness is greater than "0", and the accumulated time can also be modified via the bus, and send it after the device is restarted. |                                      |                          |                              |                |   |
| <b>104</b>   | <b>Reset operating hours counter</b> | <b>Channel A-{{...}}</b> | <b>1bit</b>                  | <b>C,W</b>     | <b>1.015 reset</b>                                  |
| The communication object is used to reset the accumulated operating time to 0. Telegrams:<br><br>1—Reset<br><br>0—NA   |                                      |                          |                              |                |   |
| <b>105</b>   | <b>Exceedance of operating hours</b> | <b>Channel A-{{...}}</b> | <b>1bit</b>                  | <b>C,R,T</b>   | <b>1.005 alarm</b>                                  |
| The communication object is used to send the status to the bus when the accumulated operating time exceeds the threshold, remind user the exceedance. Send the status when voltage recovery.<br>Telegrams:<br><br>1—Exceed<br><br>0—Normal                                       |                                      |                          |                              |                |   |

Table 6.2 "Output setting" communication object table

### 6.3."Logic" Communication Object

#### 6.3.1."AND/OR/XOR" Communication Object

| Number | Name      | Object Function | Description | Group Address | Length | C | R | W | T | U | Data Type | Priority |
|--------|-----------|-----------------|-------------|---------------|--------|---|---|---|---|---|-----------|----------|
| 6      | 1st Logic | Input a         |             |               | 1 bit  | C | - | W | T | U | boolean   | Low      |
| 7      | 1st Logic | Input b         |             |               | 1 bit  | C | - | W | T | U | boolean   | Low      |
| 8      | 1st Logic | Input c         |             |               | 1 bit  | C | - | W | T | U | boolean   | Low      |
| 9      | 1st Logic | Input d         |             |               | 1 bit  | C | - | W | T | U | boolean   | Low      |
| 10     | 1st Logic | Input e         |             |               | 1 bit  | C | - | W | T | U | boolean   | Low      |
| 11     | 1st Logic | Input f         |             |               | 1 bit  | C | - | W | T | U | boolean   | Low      |
| 12     | 1st Logic | Input g         |             |               | 1 bit  | C | - | W | T | U | boolean   | Low      |
| 13     | 1st Logic | Input h         |             |               | 1 bit  | C | - | W | T | U | boolean   | Low      |
| 14     | 1st Logic | Logic result    |             |               | 1 bit  | C | - | - | T | - | boolean   | Low      |

Fig.6.3.1 "AND/OR/XOR" communication object

| NO.   | Object Function      | Name                 | Data Type   | Flag           | DPT                  |
|---|----------------------|----------------------|-------------|----------------|----------------------|
| 6/.../13  | <b>Input a/b/..h</b> | <b>{{1st Logic}}</b> | <b>1bit</b> | <b>C,W,T,U</b> | <b>1.002 boolean</b> |
| <p>The communication object is used to receive the value of logical input Input a/b/..h.</p> <p>The name in parentheses changes with the parameter "Description for logic function". If description is empty, display "1st Logic" by default. The same below.</p> |                      |                      |             |                |                      |
| 14  | <b>Logic result</b>  | <b>{{1st Logic}}</b> | <b>1bit</b> | <b>C,T</b>     | <b>1.002 boolean</b> |
| <p>The communication object is used to send the results of logical operation.</p>   |                      |                      |             |                |                      |

Table 6.3.1 "AND/OR/XOR" communication object table

### 6.3.2. "Gate forwarding" Communication Object

|   | Number | Name      | Object Function   | Description | Group Address | Length | C | R | W | T | U | Data Type    | Priority |
|---|--------|-----------|-------------------|-------------|---------------|--------|---|---|---|---|---|--------------|----------|
| ■ | 6      | 1st Logic | Gate value select |             |               | 1 byte | C | - | W | - | - | scene number | Low      |
| ■ | 7      | 1st Logic | Input A           |             |               | 1 bit  | C | - | W | - | - | switch       | Low      |
| ■ | 8      | 1st Logic | Input B           |             |               | 1 bit  | C | - | W | - | - | switch       | Low      |
| ■ | 9      | 1st Logic | Input C           |             |               | 1 bit  | C | - | W | - | - | switch       | Low      |
| ■ | 10     | 1st Logic | Input D           |             |               | 1 bit  | C | - | W | - | - | switch       | Low      |
| ■ | 11     | 1st Logic | Output A          |             |               | 1 bit  | C | - | - | T | - | switch       | Low      |
| ■ | 12     | 1st Logic | Output B          |             |               | 1 bit  | C | - | - | T | - | switch       | Low      |
| ■ | 13     | 1st Logic | Output C          |             |               | 1 bit  | C | - | - | T | - | switch       | Low      |
| ■ | 14     | 1st Logic | Output D          |             |               | 1 bit  | C | - | - | T | - | switch       | Low      |

Fig.6.3.2 "Gate forwarding" communication object

| NO.  | Object Function          | Name                 | Data Type                                  | Flag       | DPT  |
|--|--------------------------|----------------------|--|------------|--|
| <b>6</b>   | <b>Gate value select</b> | <b>{{1st Logic}}</b> | <b>1byte</b>                               | <b>C,W</b> | <b>17.001 scene number</b>   |
| The communication object is used to select the scene of logical gate forwarding.   |                          |                      |  |            |  |
| <b>7/.../10</b>  | <b>Input x</b>           | <b>{{1st Logic}}</b> | <b>1bit</b><br><b>4bit</b><br><b>1byte</b> | <b>C,W</b> | <b>1.001 switch</b><br><b>3.007 dimming control</b><br><b>5.010 counter pulses(0..255)</b> |
| The communication object is used to receive the value of the logic gate input Input x.   |                          |                      |  |            |  |
| <b>11/.../14</b>   | <b>Output x</b>          | <b>{{1st Logic}}</b> | <b>1bit</b><br><b>4bit</b><br><b>1byte</b> | <b>C,T</b> | <b>1.001 switch</b><br><b>3.007 dimming control</b><br><b>5.010 counter pulses(0..255)</b> |
| The communication object is used to output the value forwarded by the logic gate. The output value is the same as the input value, but one input can be forwarded into one or more outputs, set by parameters. |                          |                      |  |            |  |

Table 6.3.2 "Gate forwarding" communication object table

### 6.3.3. "Threshold comparator" Communication Object

| Number | Name      | Object Function       | Description | Group Address | Length  | C | R | W | T | U | Data Type                 | Priority |
|--------|-----------|-----------------------|-------------|---------------|---------|---|---|---|---|---|---------------------------|----------|
| 6      | 1st Logic | Threshold value input |             |               | 4 bit   | C | - | W | - | U | dimming control           | Low      |
| 6      | 1st Logic | Threshold value input |             |               | 1 byte  | C | - | W | - | U | counter pulses (0..255)   | Low      |
| 6      | 1st Logic | Threshold value input |             |               | 2 bytes | C | - | W | - | U | pulses                    | Low      |
| 6      | 1st Logic | Threshold value input |             |               | 2 bytes | C | - | W | - | U | 2-byte signed value       | Low      |
| 6      | 1st Logic | Threshold value input |             |               | 2 bytes | C | - | W | - | U | 2-byte float value        | Low      |
| 6      | 1st Logic | Threshold value input |             |               | 4 bytes | C | - | W | - | U | counter pulses (unsigned) | Low      |
| 6      | 1st Logic | Threshold value input |             |               | 2 bytes | C | - | W | - | U | temperature (°C)          | Low      |
| 6      | 1st Logic | Threshold value input |             |               | 2 bytes | C | - | W | - | U | humidity (%)              | Low      |
| 6      | 1st Logic | Threshold value input |             |               | 2 bytes | C | - | W | - | U | lux (Lux)                 | Low      |
| 14     | 1st Logic | Logic result          |             |               | 1 bit   | C | - | - | T | - | boolean                   | Low      |

Fig.6.3.3 "Threshold comparator" communication object

| NO.  | Object Function       | Name          | Data Type                       | Flag  | DPT  |
|--|-----------------------|---------------|---------------------------------|-------|--|
| 6  | Threshold value input | {{1st Logic}} | 4bit<br>1byte<br>2byte<br>4byte | C,W,U | 3.007 dimming<br>5.010 counter pulses<br>7.001 pulses<br>12.001 counter pulses |
| The communication object is used to input threshold value.   |                       |               |                                 |       |  |
| 14   | Logic result          | {{1st Logic}} | 1bit                            | C,T   | 1.002 boolean  |
| The communication object is used to send the results of logical operation. That is, the value that should be sent after the object input threshold is compared with the setting threshold value. |                       |               |                                 |       |  |

Table 6.3.3 "Threshold comparator" communication object table

### 6.3.4. "Format convert" Communication Object

| Number | Name      | Object Function | Description | Group Address | Length | C | R | W | T | U | Data Type      | Priority |
|--------|-----------|-----------------|-------------|---------------|--------|---|---|---|---|---|----------------|----------|
| 6      | 1st Logic | Input 1bit-bit0 |             |               | 1 bit  | C | - | W | - | U | boolean        | Low      |
| 7      | 1st Logic | Input 1bit-bit1 |             |               | 1 bit  | C | - | W | - | U | boolean        | Low      |
| 14     | 1st Logic | Output 2bit     |             |               | 2 bit  | C | - | - | T | - | switch control | Low      |

"2x1bit --> 1x2bit"function: converts two 1bit values to a 2bit value, such as Input bit1=1, bit0=0--> Output 2bit=2

| Number | Name      | Object Function | Description | Group Address | Length | C | R | W | T | U | Data Type               | Priority |
|--------|-----------|-----------------|-------------|---------------|--------|---|---|---|---|---|-------------------------|----------|
| 6      | 1st Logic | Input 1bit-bit0 |             |               | 1 bit  | C | - | W | - | U | boolean                 | Low      |
| 7      | 1st Logic | Input 1bit-bit1 |             |               | 1 bit  | C | - | W | - | U | boolean                 | Low      |
| 8      | 1st Logic | Input 1bit-bit2 |             |               | 1 bit  | C | - | W | - | U | boolean                 | Low      |
| 9      | 1st Logic | Input 1bit-bit3 |             |               | 1 bit  | C | - | W | - | U | boolean                 | Low      |
| 10     | 1st Logic | Input 1bit-bit4 |             |               | 1 bit  | C | - | W | - | U | boolean                 | Low      |
| 11     | 1st Logic | Input 1bit-bit5 |             |               | 1 bit  | C | - | W | - | U | boolean                 | Low      |
| 12     | 1st Logic | Input 1bit-bit6 |             |               | 1 bit  | C | - | W | - | U | boolean                 | Low      |
| 13     | 1st Logic | Input 1bit-bit7 |             |               | 1 bit  | C | - | W | - | U | boolean                 | Low      |
| 14     | 1st Logic | Output 1byte    |             |               | 1 byte | C | - | - | T | - | counter pulses (0..255) | Low      |

"8x1bit --> 1x1byte"function: converts eight 1bit values to a 1byte value, such as Input bit2=1, bit1=1, bit0=1, other bits are 0--> Output 1byte=7

| Number | Name      | Object Function | Description | Group Address | Length  | C | R | W | T | U | Data Type               | Priority |
|--------|-----------|-----------------|-------------|---------------|---------|---|---|---|---|---|-------------------------|----------|
| 6      | 1st Logic | Input 1byte     |             |               | 1 byte  | C | - | W | - | U | counter pulses (0..255) | Low      |
| 14     | 1st Logic | Output 2byte    |             |               | 2 bytes | C | - | - | T | - | pulses                  | Low      |

"1x1byte --> 1x2byte"function: converts one 1byte values to a 2byte value, such as Input 1byte=125--> Output 2byte=125. Although the value remains the same, the data type of the value is different.

| Number | Name      | Object Function  | Description | Group Address | Length  | C | R | W | T | U | Data Type               | Priority |
|--------|-----------|------------------|-------------|---------------|---------|---|---|---|---|---|-------------------------|----------|
| 6      | 1st Logic | Input 1byte-low  |             |               | 1 byte  | C | - | W | - | U | counter pulses (0..255) | Low      |
| 7      | 1st Logic | Input 1byte-high |             |               | 1 byte  | C | - | W | - | U | counter pulses (0..255) | Low      |
| 14     | 1st Logic | Output 2byte     |             |               | 2 bytes | C | - | - | T | - | pulses                  | Low      |

"2x1byte --> 1x2byte"function: converts two 1byte values to a 2byte value, such as Input 1byte-low = 255 (\$FF), Input 1byte-high = 100 (\$64) --> Output 2byte = 25855 (\$64 FF)

| Number | Name      | Object Function  | Description | Group Address | Length  | C | R | W | T | U | Data Type                 | Priority |
|--------|-----------|------------------|-------------|---------------|---------|---|---|---|---|---|---------------------------|----------|
| 6      | 1st Logic | Input 2byte-low  |             |               | 2 bytes | C | - | W | - | U | pulses                    | Low      |
| 7      | 1st Logic | Input 2byte-high |             |               | 2 bytes | C | - | W | - | U | pulses                    | Low      |
| 14     | 1st Logic | Output 4byte     |             |               | 4 bytes | C | - | - | T | - | counter pulses (unsigned) | Low      |

"2x2byte --> 1x4byte"function: converts two 2 byte values to a 4byte value, such as Input 2byte-low = 65530 (\$FF FA), Input 2byte-high = 32768 (\$80 00)--> Output 2byte = 2147549178 (\$80 00 FF FA)

| Number | Name      | Object Function  | Description | Group Address | Length | C | R | W | T | U | Data Type               | Priority |
|--------|-----------|------------------|-------------|---------------|--------|---|---|---|---|---|-------------------------|----------|
| 6      | 1st Logic | Input 1byte      |             |               | 1 byte | C | - | W | - | U | counter pulses (0..255) | Low      |
| 7      | 1st Logic | Output 1bit-bit0 |             |               | 1 bit  | C | - | - | T | - | boolean                 | Low      |
| 8      | 1st Logic | Output 1bit-bit1 |             |               | 1 bit  | C | - | - | T | - | boolean                 | Low      |
| 9      | 1st Logic | Output 1bit-bit2 |             |               | 1 bit  | C | - | - | T | - | boolean                 | Low      |
| 10     | 1st Logic | Output 1bit-bit3 |             |               | 1 bit  | C | - | - | T | - | boolean                 | Low      |
| 11     | 1st Logic | Output 1bit-bit4 |             |               | 1 bit  | C | - | - | T | - | boolean                 | Low      |
| 12     | 1st Logic | Output 1bit-bit5 |             |               | 1 bit  | C | - | - | T | - | boolean                 | Low      |
| 13     | 1st Logic | Output 1bit-bit6 |             |               | 1 bit  | C | - | - | T | - | boolean                 | Low      |
| 14     | 1st Logic | Output 1bit-bit7 |             |               | 1 bit  | C | - | - | T | - | boolean                 | Low      |

"1x1byte --> 8x1bit" function: converts one 1byte values to eight 1bit value, such as Input 1byte=200 --> Output bit0=0, bit1=0, bit2=0, bit3=1, bit4=0, bit5=0, bit6=1, bit7=1

| Number | Name      | Object Function   | Description | Group Address | Length  | C | R | W | T | U | Data Type               | Priority |
|--------|-----------|-------------------|-------------|---------------|---------|---|---|---|---|---|-------------------------|----------|
| 6      | 1st Logic | Input 2byte       |             |               | 2 bytes | C | - | W | - | U | pulses                  | Low      |
| 13     | 1st Logic | Output 1byte-low  |             |               | 1 byte  | C | - | - | T | - | counter pulses (0..255) | Low      |
| 14     | 1st Logic | Output 1byte-high |             |               | 1 byte  | C | - | - | T | - | counter pulses (0..255) | Low      |

"1x2byte --> 2x1byte"function: converts one 2byte values to two 2byte value, such as Input 2byte = 55500

(\$D8 CC) --> Output 1byte-low = 204 (\$CC), Output 1byte-high =216 (\$D8)

| Number | Name      | Object Function   | Description | Group Address | Length  | C | R | W | T | U | Data Type                 | Priority |
|--------|-----------|-------------------|-------------|---------------|---------|---|---|---|---|---|---------------------------|----------|
| 6      | 1st Logic | Input 4byte       |             |               | 4 bytes | C | - | W | - | U | counter pulses (unsigned) | Low      |
| 13     | 1st Logic | Output 2byte-low  |             |               | 2 bytes | C | - | - | T | - | pulses                    | Low      |
| 14     | 1st Logic | Output 2byte-high |             |               | 2 bytes | C | - | - | T | - | pulses                    | Low      |

"1x4byte --> 2x2byte"function: converts one 4byte values to two 2byte value, such as Input 4byte = 78009500 (\$04 A6 54 9C) --> Output 2byte-low = 21660 (\$54 9C), Output 2byte-high =1190 (\$04 A6)

| Number | Name      | Object Function     | Description | Group Address | Length  | C | R | W | T | U | Data Type               | Priority |
|--------|-----------|---------------------|-------------|---------------|---------|---|---|---|---|---|-------------------------|----------|
| 6      | 1st Logic | Input 3byte         |             |               | 3 bytes | C | - | W | - | U | RGB value 3x(0..255)    | Low      |
| 12     | 1st Logic | Output 1byte-low    |             |               | 1 byte  | C | - | - | T | - | counter pulses (0..255) | Low      |
| 13     | 1st Logic | Output 1byte-middle |             |               | 1 byte  | C | - | - | T | - | counter pulses (0..255) | Low      |
| 14     | 1st Logic | Output 1byte-high   |             |               | 1 byte  | C | - | - | T | - | counter pulses (0..255) | Low      |

"1x3byte --> 3x1byte"function: converts one 3byte values to three 1byte value, such as Input 3byte = \$78 64 C8--> Output 1byte-low = 200 (\$C8) , Output 1byte-middle = 100 (\$64) , Output 1byte-high =120 (\$78)

| Number | Name      | Object Function    | Description | Group Address | Length  | C | R | W | T | U | Data Type               | Priority |
|--------|-----------|--------------------|-------------|---------------|---------|---|---|---|---|---|-------------------------|----------|
| 6      | 1st Logic | Input 1byte-low    |             |               | 1 byte  | C | - | W | - | U | counter pulses (0..255) | Low      |
| 7      | 1st Logic | Input 1byte-middle |             |               | 1 byte  | C | - | W | - | U | counter pulses (0..255) | Low      |
| 8      | 1st Logic | Input 1byte-high   |             |               | 1 byte  | C | - | W | - | U | counter pulses (0..255) | Low      |
| 14     | 1st Logic | Output 3byte       |             |               | 3 bytes | C | - | - | T | - | RGB value 3x(0..255)    | Low      |

"3x1byte --> 1x3byte"function: converts three 1byte values to a 3byte value, such as Input 1byte-low = 150 (\$96), Input 1byte-middle = 100 (\$64), Input 1byte-high = 50 (\$32)--> Output 3byte = \$32 64 96

Fig.6.3.4 "Format convert" communication object

| NO.   | Object Function       | Name          | Data Type | Flag  | DPT                          |
|---|-----------------------|---------------|-----------|-------|------------------------------|
| 6   | Input ...             | {{1st Logic}} | 1bit      | C,W,U | 1.001 switch                 |
|   |                       |               | 1byte     |       | 5.010 counter pulses(0..255) |
|   |                       |               | 2byte     |       | 7.001 pulses                 |
|   |                       |               | 3byte     |       | 232.600 RGB value 3x(0..255) |
|   |                       |               | 4byte     |       | 12.001 counter pulses        |
| The communication object is used to input a value that needs to be converted. |                       |               |           |       |                              |
| 14  | Output ...            | {{1st Logic}} | 1bit      | C,T   | 1.001 switch                 |
|   |                       |               | 2bit      |       | 2.001 switch control         |
|   |                       |               | 1byte     |       | 5.010 counter pulses(0..255) |
|   |                       |               | 2byte     |       | 7.001 pulses                 |
|   |                       |               | 3byte     |       | 232.600 RGB value 3x(0..255) |
| 4byte   | 12.001 counter pulses |               |           |       |                              |
| The communication object is used to output the converted value.               |                       |               |           |       |                              |

Table 6.3.4 "Format convert" communication object table

### 6.3.5. "Gate function" Communication Object

| Number                         | Name      | Object Function | Description | Group Address | Length  | C | R | W | T | U | Data Type               | Priority |
|--------------------------------|-----------|-----------------|-------------|---------------|---------|---|---|---|---|---|-------------------------|----------|
| 6                              | 1st Logic | Input           |             |               | 1 bit   | C | - | W | - | - | switch                  | Low      |
| 7                              | 1st Logic | Gate input      |             |               | 1 bit   | C | - | W | - | - | boolean                 | Low      |
| 14                             | 1st Logic | Output          |             |               | 1 bit   | C | - | - | T | - | switch                  | Low      |
| Input/Output - 1bit[On/Off]    |           |                 |             |               |         |   |   |   |   |   |                         |          |
| 6                              | 1st Logic | Input           |             |               | 1 byte  | C | - | W | - | - | percentage (0..100%)    | Low      |
| 7                              | 1st Logic | Gate input      |             |               | 1 bit   | C | - | W | - | - | boolean                 | Low      |
| 14                             | 1st Logic | Output          |             |               | 1 byte  | C | - | - | T | - | percentage (0..100%)    | Low      |
| Input/Output - 1byte[0..100%]  |           |                 |             |               |         |   |   |   |   |   |                         |          |
| 6                              | 1st Logic | Input           |             |               | 1 byte  | C | - | W | - | - | counter pulses (0..255) | Low      |
| 7                              | 1st Logic | Gate input      |             |               | 1 bit   | C | - | W | - | - | boolean                 | Low      |
| 14                             | 1st Logic | Output          |             |               | 1 byte  | C | - | - | T | - | counter pulses (0..255) | Low      |
| Input/Output - 1byte[0..255]   |           |                 |             |               |         |   |   |   |   |   |                         |          |
| 6                              | 1st Logic | Input           |             |               | 2 bytes | C | - | W | - | - | temperature (°C)        | Low      |
| 7                              | 1st Logic | Gate input      |             |               | 1 bit   | C | - | W | - | - | boolean                 | Low      |
| 14                             | 1st Logic | Output          |             |               | 2 bytes | C | - | - | T | - | temperature (°C)        | Low      |
| Input/Output - 2byte[Float]    |           |                 |             |               |         |   |   |   |   |   |                         |          |
| 6                              | 1st Logic | Input           |             |               | 2 bytes | C | - | W | - | - | pulses                  | Low      |
| 7                              | 1st Logic | Gate input      |             |               | 1 bit   | C | - | W | - | - | boolean                 | Low      |
| 14                             | 1st Logic | Output          |             |               | 2 bytes | C | - | - | T | - | pulses                  | Low      |
| Input/Output - 2byte[0..65535] |           |                 |             |               |         |   |   |   |   |   |                         |          |

Fig.6.3.5 "Gate function" communication object

| NO.  | Object Function | Name          | Data Type | Flag | DPT                  |
|--|-----------------|---------------|-----------|------|----------------------|
| 6  | Input           | {{1st Logic}} | 1bit      | C,W  | 1.001 switch         |
|  |                 |               | 1byte     |      | 5.001 percentage     |
|  |                 |               | 2byte     |      | 5.010 counter pulses |
|  |                 |               |           |      | 9.001 temperature    |
|  |                 |               |           |      | 7.001 pulses         |
| The communication object is used to input a value that needs to gate filter.   |                 |               |           |      |                      |
| 7  | Gate input      | {{1st Logic}} | 1bit      | C,W  | 1.002 boolean        |
| The communication object is used to control the switch status of gate input. Input signal is allowed to pass when gate open, then output, and the current input status is still sent if there is a change; Can not pass when gate close. |                 |               |           |      |                      |
| 14   | Output          | {{1st Logic}} | bit       | C,T  | 1.001 switch         |
|  |                 |               | 1byte     |      | 5.001 percentage     |
|  |                 |               | 2byte     |      | 5.010 counter pulses |
|  |                 |               |           |      | 9.001 temperature    |
|  |                 |               |           |      | 7.001 pulses         |
| The communication object is used to output the value after gate filtering. Only when gate input status is open, output is available, defined by the object "Gate input".   |                 |               |           |      |                      |

Table 6.3.5 "Gate function" communication object table

### 6.3.6."Delay function" Communication Object

| Number          | Name      | Object Function | Description | Group Address | Length  | C | R | W | T | U | Data Type               | Priority |
|-----------------|-----------|-----------------|-------------|---------------|---------|---|---|---|---|---|-------------------------|----------|
| 6               | 1st Logic | Input           |             |               | 1 bit   | C | - | W | - | - | switch                  | Low      |
| 14              | 1st Logic | Output          |             |               | 1 bit   | C | - | - | T | - | switch                  | Low      |
| 1bit[On/Off]    |           |                 |             |               |         |   |   |   |   |   |                         |          |
| 6               | 1st Logic | Input           |             |               | 1 byte  | C | - | W | - | - | percentage (0..100%)    | Low      |
| 14              | 1st Logic | Output          |             |               | 1 byte  | C | - | - | T | - | percentage (0..100%)    | Low      |
| 1byte[0..100%]  |           |                 |             |               |         |   |   |   |   |   |                         |          |
| 6               | 1st Logic | Input           |             |               | 1 byte  | C | - | W | - | - | counter pulses (0..255) | Low      |
| 14              | 1st Logic | Output          |             |               | 1 byte  | C | - | - | T | - | counter pulses (0..255) | Low      |
| 1byte[0..255]   |           |                 |             |               |         |   |   |   |   |   |                         |          |
| 6               | 1st Logic | Input           |             |               | 2 bytes | C | - | W | - | - | temperature (°C)        | Low      |
| 14              | 1st Logic | Output          |             |               | 2 bytes | C | - | - | T | - | temperature (°C)        | Low      |
| 2byte[Float]    |           |                 |             |               |         |   |   |   |   |   |                         |          |
| 6               | 1st Logic | Input           |             |               | 2 bytes | C | - | W | - | - | pulses                  | Low      |
| 14              | 1st Logic | Output          |             |               | 2 bytes | C | - | - | T | - | pulses                  | Low      |
| 2byte[0..65535] |           |                 |             |               |         |   |   |   |   |   |                         |          |

Fig.6.3.6 "Delay function" communication object

| NO.   | Object Function | Name          | Data Type              | Flag | DPT   |
|---|-----------------|---------------|------------------------|------|---|
| 6   | Input           | {{1st Logic}} | 1bit<br>1byte<br>2byte | C,W  | 1.001 switch<br>5.001 percentage<br>5.010 counter pulses<br>9.001 temperature<br>7.001 pulses |
| The communication object is used to input a value that needs to delay.  |                 |               |                        |      |   |
| 14  | Output          | {{1st Logic}} | 1bit<br>1byte<br>2byte | C,T  | 1.001 switch<br>5.001 percentage<br>5.010 counter pulses<br>9.001 temperature<br>7.001 pulses |
| The communication object is used to output that needs to delay converted value, delay time is defined by the parameter. |                 |               |                        |      |   |

Table 6.3.6 "Delay function" communication object table

### 6.3.7. "Staircase lighting" Communication Object

| Number | Name      | Object Function        | Description | Group Address | Length  | C | R | W | T | U | Data Type               | Priority |
|--------|-----------|------------------------|-------------|---------------|---------|---|---|---|---|---|-------------------------|----------|
| 6      | 1st Logic | Trigger value          |             |               | 1 bit   | C | - | W | - | - | trigger                 | Low      |
| 7      | 1st Logic | Light-on duration time |             |               | 2 bytes | C | - | W | - | - | time (s)                | Low      |
| 14     | 1st Logic | Output                 |             |               | 1 bit   | C | - | - | T | - | switch                  | Low      |
| 14     | 1st Logic | Output                 |             |               | 1 byte  | C | - | - | T | - | counter pulses (0..255) | Low      |

Fig.6.3.7 "Staircase lighting" communication object

| NO.  | Object Function        | Name          | Data Type     | Flag | DPT                                  |
|--|------------------------|---------------|---------------|------|--------------------------------------|
| 6  | Trigger value          | {{1st Logic}} | 1bit          | C,W  | 1.017 trigger                        |
| The communication object is used to receive the value to trigger staircase lighting.   |                        |               |               |      |                                      |
| 7  | Light-on duration time | {{1st Logic}} | 2byte         | C,W  | 7.005 time(s)                        |
| The communication object is used to modify the staircase light-on duration time, the modified range is referenced from the range defined by the parameter, take the limit value if exceeded. |                        |               |               |      |                                      |
| 14   | Output                 | {{1st Logic}} | 1bit<br>1byte | C,T  | 1.001 switch<br>5.010 counter pulses |
| The communication object is used to output value 1 when trigger, and send value 2 after duration time. Telegram value is determined by the parameter setting datatype.                       |                        |               |               |      |                                      |

Table 6.3.7 "Staircase lighting" communication object table