

DETRONS™

KNX Power Supply, 640mA

DPS.640.3

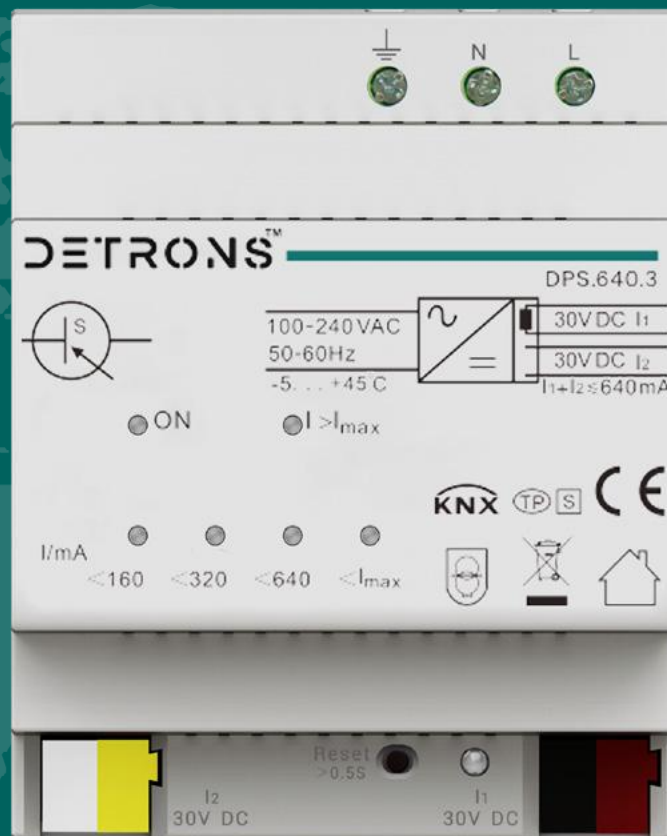

KNX/EIB Home and Building Control System
Attentions

Attentions

1. Please keep devices away from strong magnetic field, high temperature, wet environment;



2. Do not fall the device to the ground or make them get hard impact;



3. Do not use wet cloth or volatile reagent to wipe the device;



4. Do not disassemble the devices.

Content

Chapter 1 Introduction	1
Chapter 2 Technical Parameter	2
Chapter 3 Dimension and Connection Diagram	3
3.1. Dimension drawing	3
3.2. Connection Diagram	4
Chapter 4 Normal Working Test	5

Important safeguards

1) Before use, please read this instruction carefully and use the power supply strictly according to the instruction.

2) This power supply is for indoor use only and shall be installed in distribution box which can provide the protection mechanism for avoid electric shock.

3) Please keep this equipment from humidity.

4) Before use, the input and output voltage must be checked to secure correct use.

5) The cover may under no circumstances be opened. If the cover is damaged, then the adaptor may no longer be used.

6) The power supply shall be installed and used according to national wiring rules.

7) For indoor use only.

8) The product is not a toy, keep it where the children cannot reach it.

9) The power supply is only supply for KNX system equipment with bus line connection terminal.

10) Correct Disposal of this product:

This marking indicates that this product should not be disposed with other household wastes throughout the EU. To prevent possible harm to the environment or human health from uncontrolled waste disposal, recycle it responsibly to promote the sustainable reuse of material resources. To return your used device, please use the return and collection systems or contact the retailer where the product was purchased. They can take this product for environmentally safe recycling.



Chapter1 Introduction

KNX power supply produces and monitors KNX system voltage. There are two connection terminals of the output, one for KNX bus supply and signal transmission, one for auxiliary power supply, can provide 30V DC voltage with terminal device. The bus connection terminal has integrated the reactor inside the power supply; if the auxiliary power supply terminal is connected with an external reactor, it can also be used as the bus power supply terminal, and also with the function of signal transmission.

The KNX power supply is an analog-to-digital installation equipment. In order to facilitate the installation in the distribution box, according to the design of EN 60 715, it can be installed on a 35mm DIN rail. The device is connected with the screw post for electrical connection. The bus connection is directly connected through the KNX connection terminal (red/ black). The auxiliary power supply is also connected directly through the KNX connection terminal (yellow/ white), and the input end is connected to the power supply voltage of 230V AC.

A reset of the power supply is triggered by pressing the reset button last for 22 seconds (it does not include the time for button action). When bus supply terminal is disconnected from the power supply, other devices on the bus will return to their initial state. If bus disconnect for a longer period, the bus supply terminal must be removed from power supply.

Chapter 2 Technical Parameter

Power supply	Input voltage	100-240V AC, 50-60Hz
	Efficiency	≥80%
Output	KNX output	1-fold with integrated choke
	KNX nominal voltage	30+1V/-2V DC, SELV
	Auxiliary voltage output	1-fold without integrated choke
	Auxiliary voltage	30±1V DC, SELV
	KNX nominal current	(Total of KNX and auxiliary voltage output) 640 mA, short-circuit-proof
	Sustained short-circuit current	<1.5A
	Mains failure buffer time	>200ms
Operation/ Display	Reset push button	22s delay reset function (Press the button >0.5s, to reset the KNX bus voltage)
	Red LED1	Reset the KNX Bus
	Green LED2	Normal operation
	Red LED3	Overload/short-circuit($I > I_{max}$)
	Green LED4	Current level2 $0 \leq I < 160(\pm 20)$ mA
	Green LED5	Current level3 $160 \leq I < 320(\pm 20)$ mA
	Green LED6	Current level4 $320 \leq I < 640(\pm 20)$ mA
	Green LED7	Current level2 $640 \leq I < I_{max}$
Connection	Power supply	3-srew terminals
	Cable cross-section	Single-core 0.5—2.5mm ²
		Multi-core 0.5—1.5mm ²
	KNX output	Bus connection terminal (Red/Black)
Auxiliary voltage output	Connection terminal (Yellow/White)	

Temperature	Operation	- 5 °C ... + 45 °C
	Storage	- 25 °C ... + 55 °C
	Transport	- 25 °C ... + 70 °C
Environment	Humidity	<93%, except dewing
Mounting	On 35mm mounting rail	
Dimension	64mm×72×90	
Weight	0.3kg	
Housing, Color	Plastic, Beige	

Chapter 3 Dimension and Connection Diagram

3.1. Dimension drawing

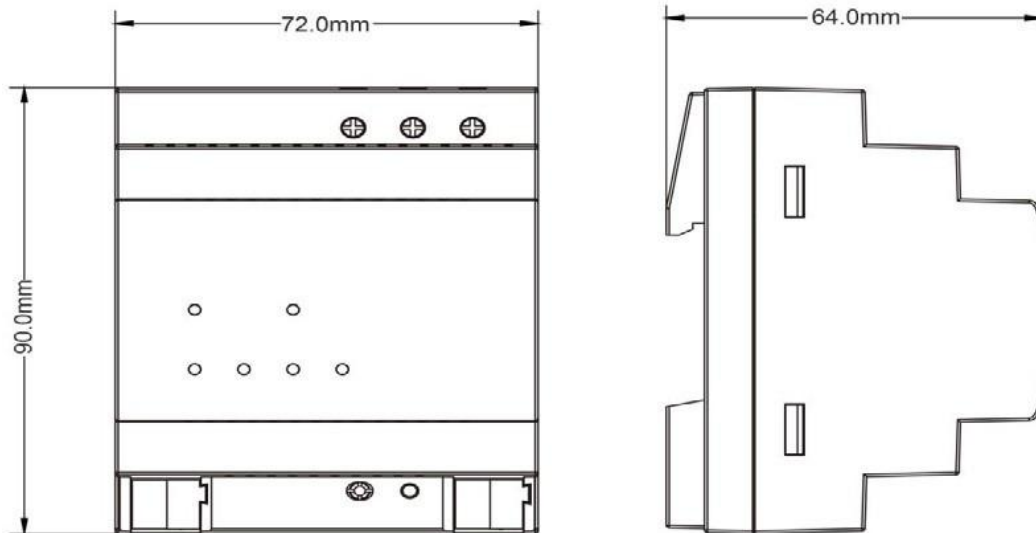

3.2. Connection Diagram

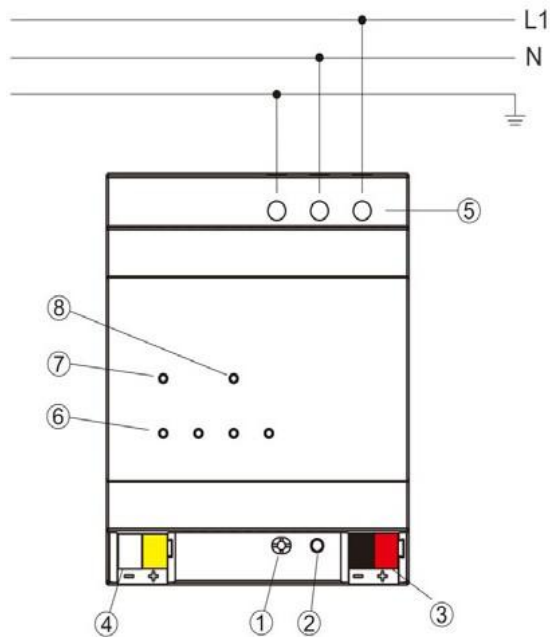

- ① Reset push button
- ② Reset indicator LED
- ③ KNX Bus connection terminal
- ④ Auxiliary voltage connection terminal
- ⑤ Main supply
- ⑥ Current level indicator
- ⑦ Output voltage normally indicator
- ⑧ Overload/short circuit indicator

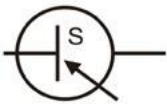

Switch mode power supply unit



Non-inherently short-circuit-proof-safety isolating transformer

Chapter 4 Normal Working Test

When power supply has been correctly installed, switch on the main power supply for the bus power, and the green LED “ON”, the circuit level indicator LEDs up according to the range of loads, and the other LEDs are switched off, that is, the device function correctly.