

TEMPERATURE CONTROLLER

CTS

User Manual:

CTS-01

CTS-06

Application Program: ver. 1.0

User Manual: ver. 1.0

module-electronic.ru

СОДЕРЖАНИЕ

Content	2
1 Basic information	4
1.1 Specification	5
1.2 Appearance	6
1.3 Instalation and conection	7
2 Terms and definitions	9
2.1 Internal sensor	9
2.2 External sensor	9
2.3 Temperature setpoint	9
2.4 Hysteresis	10
2.5 PI control (PI)	11
2.6 Pulse Width Modulation (PWM)	12
3 How to choose a device version	13
4 Settings	14
4.1 Channel activity	14
4.2 External/internal sensor	14
4.3 Internal sensor correction	15
4.4 Send actual temperature on change of	15
4.5 Send actual temperature every	15
4.6 Sensor failure alarm	15
4.7 Heat/Frost alarms	16
4.8 When temperature <	16
4.9 When temperature >	16
4.10 Temperature control	16
4.11 Sensor alarm after no temperature telegrams	17
4.12 «Comfort» mode setpoint	18
4.13 Standby mode offset	18
4.14 Economy mode offset	19
4.15 Action on reset	19
4.16 Controller direction	19
4.17 Controller type	20
4.18 Controller mode	20
4.19 Hysteresis	20
4.20 Actuating command when sensor failure	21
4.21 Heating/Cooling system	21
4.22 Proportional range, °C	22
4.23 Integration period, minutes	22
4.24 Minimum actuating value	22
4.25 Maximum actuating value	22
4.26 Actuating value when sensor failure	22
4.27 PWM period (minutes)	23
4.28 Repeat actuating command periodically	23

5	Communication objects	24
5.1	Current temperature	24
5.2	External temperature	24
5.3	Comfort setpoint	25
5.4	Actual setpoint	25
5.5	Comfort mode	25
5.6	Standby mode	25
5.7	Economy mode	26
5.8	HVAC mode	26
5.9	Controller on/off	26
5.10	Actuating command, on/off	27
5.11	Actuating command, %	27
5.12	Sensor alarm	27
5.13	Frost alarm	27
5.14	Heat alarm	28
6	Description of behavior of the device after programming	28
7	Description of behavior of the device after loss and return of bus voltage	28

1 BASIC INFORMATION

The temperature controller is designed to measure the temperature of objects using remote temperature sensors, as well as to control climate devices (heating actuators, air conditioners, etc.)

The temperature controller is available in three versions:

- CTS-01 (1 measurement/control channel, designed for installation in a wiring box);
 - CTS-06 (6 peer measurement/control channels, designed for wall mounting).
-
- Independent inputs for connecting temperature sensors
 - Various control algorithms (2-point, PI, PI PWM)
 - Sensor status monitoring
 - Operation mode selection (heating / air conditioning)
 - Alarm about overheat / subcooling
 - Saving settings during a KNX power failure
 - Power supply via KNX bus
 - Waterproof housing IP 64 (model CTS-06)

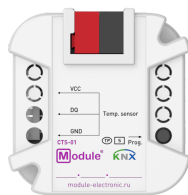

CTS-01

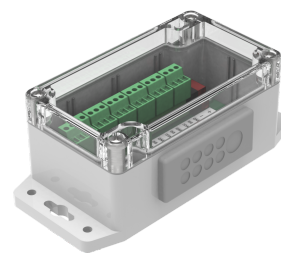

CTS-06

1.1 SPECIFICATIONS

Device model	CTS-01	CTS-06
Inputs (connection of temperature sensors)		
Number of channels	1	6
Type of temperature sensors to be connected	Dallas DS18B20 (1-wire)	
Maximum sensor cable length	50 meters	
Cross-section of the connected wire to the screw terminals	up to 1,5mm ²	
KNX interface		
Specification	TP-256	
Available application software	ETS 5	
KNX connector	4-wire EIB connector (PUSH WIRE spring clips) for standard cable TP1 0,8mm Ø	
Power supply	via KNX bus	
Consumption on the KNX bus (29V DC)	< 5mA < 150mW	< 5mA < 150mW
Operation temperature	0°C .. +45°C	
Operation humidity	5 .. 95% (no condensation)	
Degree of protection	IP 20, clean environment	IP 64, clean environment
Mounting type	wiring box	Wall mounting
Dimensions	44 x 44 x 25mm	145 x 71,5 x 55mm
Weight	29g	220g

1.2 APPEARANCE

Appearance of the temperature controller CTS-01

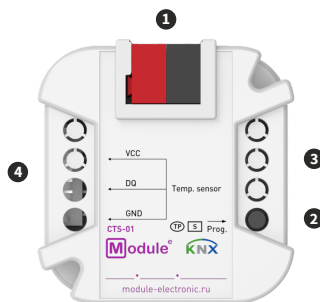

- 1. KNX connector
- 2. Programming button
- 3. Programing LED
- 4. Sensor terminal

Appearance of the temperature controller CTS-06

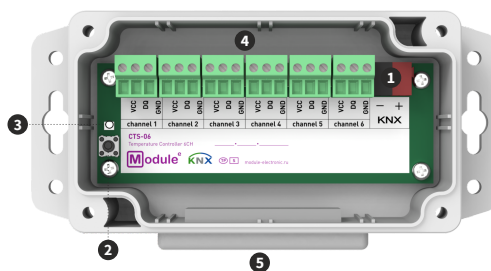

- 1. KNX connector
- 2. Programming button
- 3. Programing LED
- 4. Sensor terminals
- 5. Cable glands

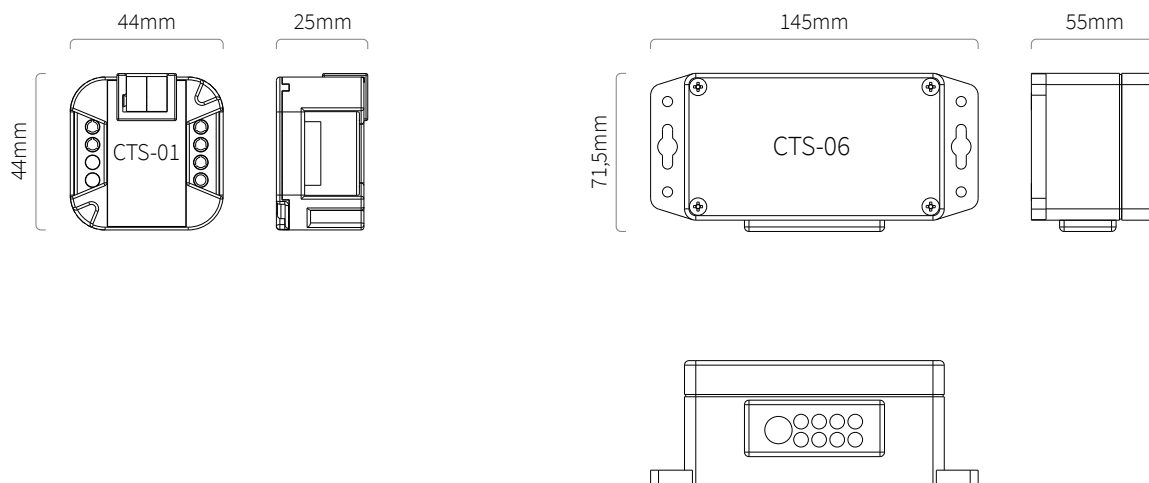

1.3 INSTALLATION AND CONNECTION

INSTALLATION CTS-06



before entering the cable Make a puncture in the center of the pressure seal membrane with an awl

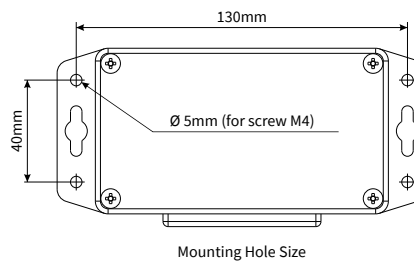
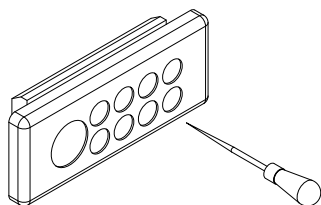

INSTALLATION CTS-01



ATTENTION! When choosing a socket or junction box be sure to consider the dimensions of the device

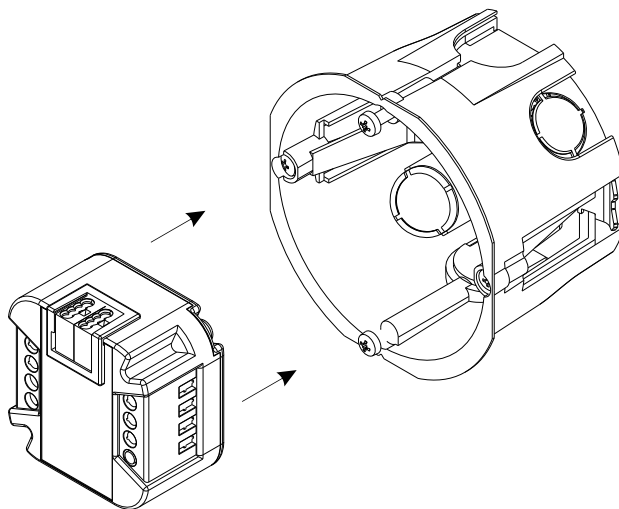

WIRING DIAGRAMS

Wiring example CTS-06 (other versions are connected in the same way)

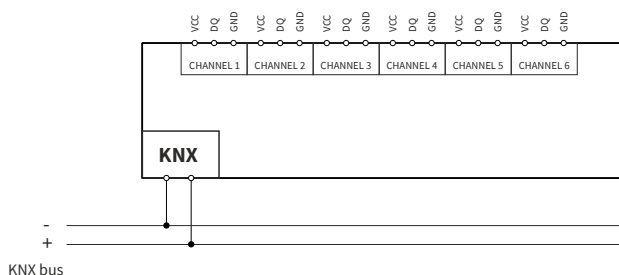

ATTENTION! Installation and connection of the device to the mains must only be carried out by qualified personnel! Be sure to turn off the power before installing or removing the device! Even when the device is turned off, the output terminals can be live! Do not connect to the outputs a load that exceeds the recommended values! The design of the device meets the requirements of electrical safety according to GOST 12.2.007.0-75.

2 TERMS AND DEFINITIONS

2.1 INTERNAL SENSOR

An internal sensor is a remote sensor DS18B20 connected to the device via a 1-wire bus.

2.2 EXTERNAL SENSOR

An external sensor is a third-party device capable of measuring temperature and transmitting readings via the KNX bus.

2.3 TEMPERATURE SETPOINT

The temperature setpoint is a parameter that directly controls the temperature. Parameter 4.11 «Comfort mode setpoint» is used to set the setpoint value for «Comfort» mode. Parameters 4.12 «Standby mode offset» and 4.13 «Economy mode offset» change the value of the current setting («Actual setpoint») relative to the comfort setpoint by the value of the corresponding offset: decrease when controlling the heater or increase when controlling the cooler.

2.5 PI CONTROL (PI)

In the proportional-integral (PI) control algorithm, the magnitude of the control action on the controlled object depends on the difference (discrepancy) between the setpoint and the temperature of the object. The algorithm takes into account both the proportional (P) and the integral component (I), i.e., the residual value accumulated over time, which enables to compensate for the systematic regulation error due to heat losses at the object.

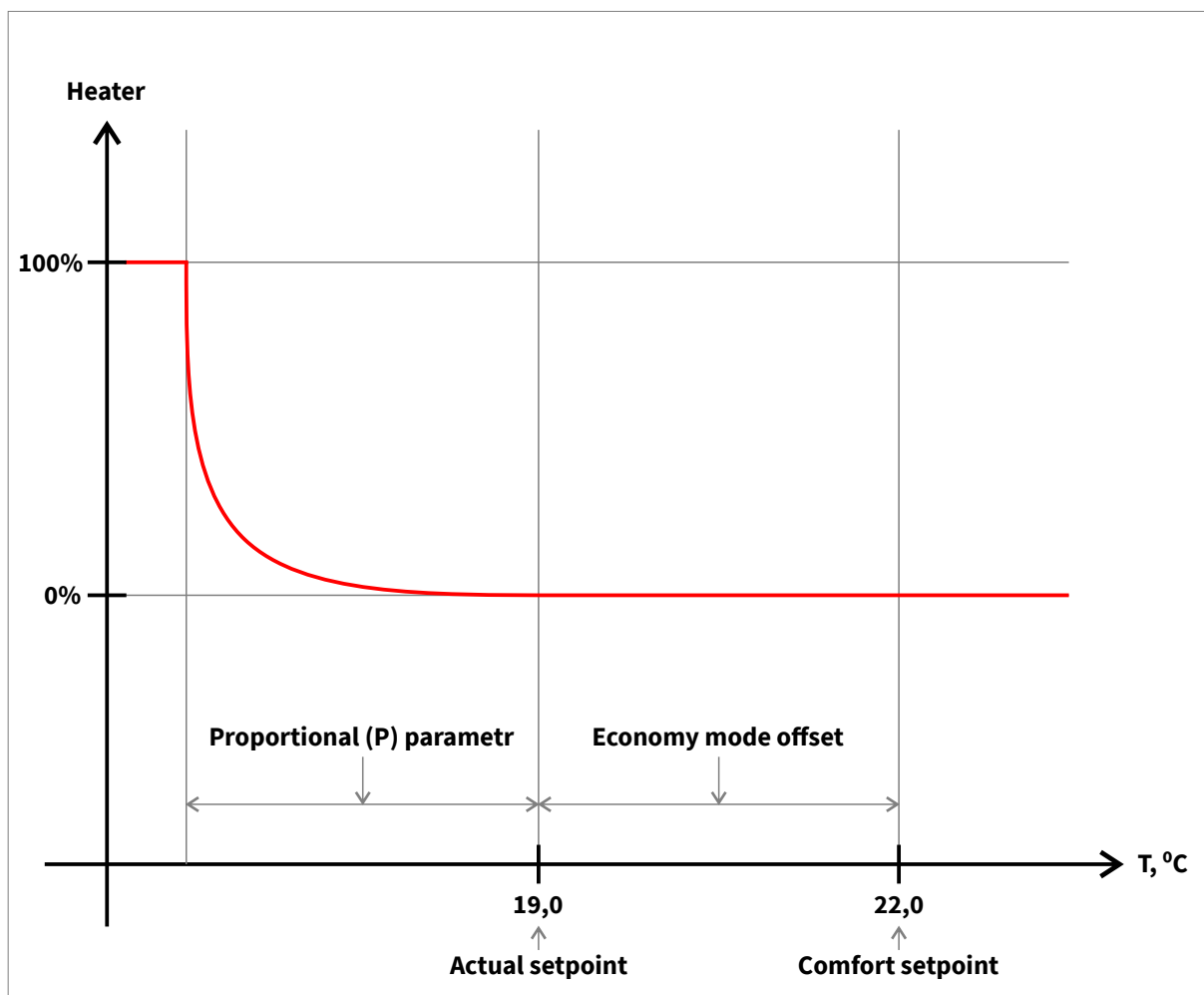

Figure 2. PI temperature control algorithm

The proportional (P) parameter of the PI control algorithm is determined by the power of the heater (cooler) and is numerically equal to the residual value, above which the control action reaches 100%.

The integral (I) parameter of the PI control algorithm is determined by the inertia of the control object.

In this mode, the control action is applied to the controlled object via a single-byte communication object (0% ... 100%).

2.6 PULSE WIDTH MODULATION (PWM)

With the PI-PWM control algorithm, the magnitude of the control action impact on the controlled object is determined similarly to the PI mode, but the control action is applied to the controlled object through pulse-width modulation: the pulse duty ratio is proportional to the magnitude of the control action.

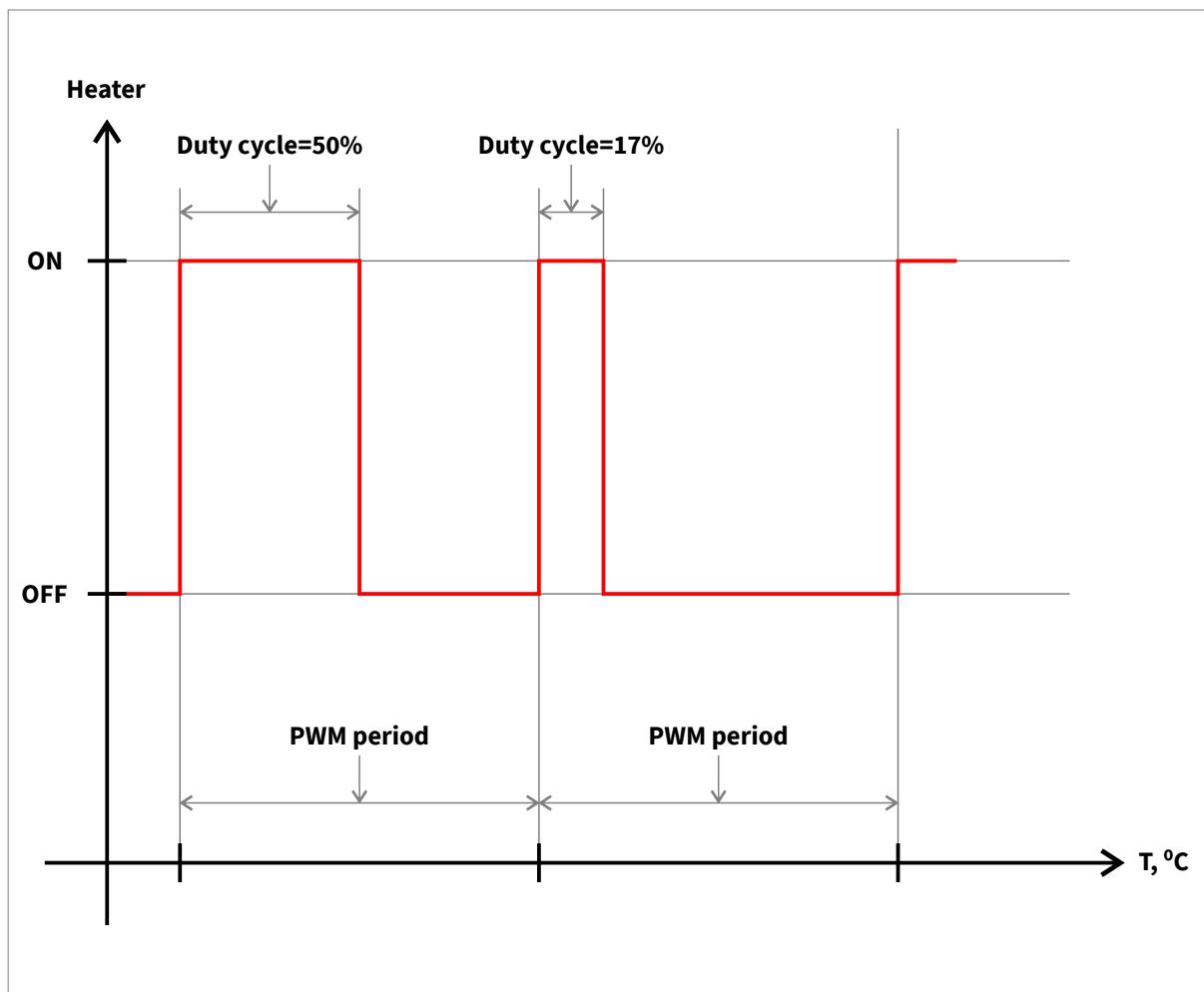

Figure 3. PI-PWM temperature control algorithm

In this mode, the control action is applied to the controlled object through an one-bit communication object (On/Off).

3 HOW TO CHOOSE A DEVICE VERSION

The option menu allows to select one of two models.

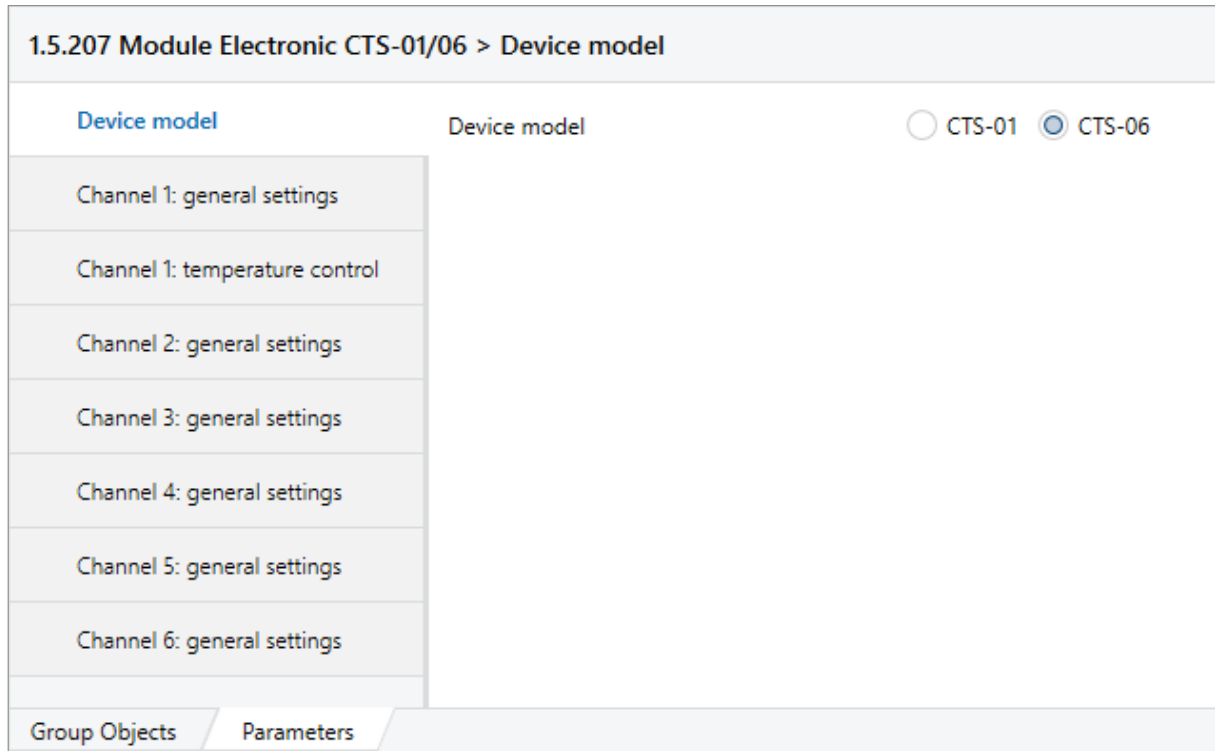

Figure 4. Tab «Device model»

Depending on the selected version, the corresponding number of tabs for each of the channels available in the selected version is displayed in the settings menu.

4 SETTINGS

The device settings menu consists of 6 individual channel tabs.

Figure 5. Tab «Channel 1: general settings» (Internal sensor)

4.1 CHANNEL ACTIVITY

If «Inactive», this channel is turned off, its internal sensor is not interrogated, communication objects associated with it are not available.

If «Active», this channel is turned on, its internal sensor is interrogated, other settings appear on the tab.

4.2 EXTERNAL/INTERNAL SENSOR

If «Internal» is selected - the device uses an internal sensor for temperature measurement and thermal control, which polls itself.

If «External» is selected - the device uses temperature readings supplied by the KNX bus from a third-party device for thermal regulation.

4.3 INTERNAL SENSOR CORRECTION

The parameter allows entering the correction of the internal sensor readings.

The correction value is indicated in 1/10 fractions of °C.

The range of available values is -100 .. + 100 (-10.0 °C..+10.0 °C), increment 1 (0.1 °C).

4.4 SEND ACTUAL TEMPERATURE ON CHANGE OF

The parameter allows sending the current temperature value when it changes more than by the value specified in the parameter (both upward and downward).

The value is indicated in 1/10 °C.

The range of allowable values is 0..20 (0.1 °C.. 2.0 °C).

If the parameter is 0, temperature values are not sent when they are changed.

4.5 SEND ACTUAL TEMPERATURE EVERY

The parameter allows sending the current temperature value by timer.

The value is indicated in minutes.

The range of allowable values is 0 .. 60, increment is 1.

If the parameter is 0, sending of temperature values by timer is not being done.

4.6 SENSOR FAILURE ALARM

If «Don't send» is selected, error events during the interrogation of the sensor are not monitored and not processed.

If «Send» is selected, in case of an sensor failure the alarms are sent, and CommObject 5.12 «Sensor alarm» becomes available.

4.7 HEAT/FROST ALARMS

If «Don't send» is selected, the control of the current temperature exceeding the permissible limits is disabled.

If «Send» is selected, the control of the current temperature exceeding the permissible limits is enabled, and alarms are sent. The parameters 4.8 «When temperature <» and 4.9 «When temperature >», as well as CommObjects 5.13 «Frost alarm» and 5.14 «Heat alarm» become available.

4.8 WHEN TEMPERATURE <

The parameter allows to set the lower allowable temperature. If the temperature drops below this value, the device sends an alarm, provided that the parameter 4.7 «Heat/Frost alarms» is set to the «Send» mode.

The value is indicated in °C. The range of allowable values is -3 .. +15, increment is 1.

4.9 WHEN TEMPERATURE >

The parameter allows to set the upper allowable temperature. If the temperature rises above this value, the device sends an alarm, provided that the parameter 4.7 «Heat/Frost alarms» is set to the «Send» mode.

The value is indicated in °C. The range of allowable values is +25 .. +50, increment is 1.

4.10 TEMPERATURE CONTROL

If «Off» is selected, the regulation is not performed, and CommObjects related to regulation are not available.

If «On» is selected, the temperature controller turns on, the tab «Temperature control» (ref. to Fig. 7, 8, 9) appears, and the following CommObjects become available:

- 5.3 «Comfort setpoint»;
- 5.4 «Actual setpoint»;
- 5.5 «Set mode Comfort»;
- 5.6 «Set mode Standby»;
- 5.7 «Set mode Economy»;
- 5.8 «Current mode»;
- 5.9 «Controller on/off»;
- 5.10 «Actuating command (on/off)»;
- 5.11 «Actuating command (%)».

1.5.207 Module Electronic CTS-01/06 > Channel 1: general settings	
Device model	Channel activity <input type="radio"/> Inactive <input checked="" type="radio"/> Active
Channel 1: general settings	Sensor <input type="radio"/> Internal <input checked="" type="radio"/> External
Channel 1: temperature control	Sensor failure alarm <input type="radio"/> Don't send <input checked="" type="radio"/> Send
Channel 2: general settings	Sensor alarm after no temperature telegrams during (minutes, 0 - don't check) <input type="text" value="1"/>
Channel 3: general settings	Heat/frost alarms <input type="radio"/> Don't send <input checked="" type="radio"/> Send
Channel 4: general settings	- when temperature < (°C) <input type="text" value="0"/>
Channel 5: general settings	- when temperature > (°C) <input type="text" value="50"/>
Channel 6: general settings	Temperature control <input type="radio"/> Off <input checked="" type="radio"/> On

Group Objects Parameters

Figure 6. Tab «Channel 1: general settings» (External sensor)

4.11 SENSOR ALARM AFTER NO TEMPERATURE TELEGRAMS

This parameter allows you to set the time during which the device waits for telegrams from the external temperature sensor. After this time, the device sends a «Sensor alarm» telegram. The value is given in minutes, the range of possible values is 0 ... 60, step is 1. If the parameter is set to «0», the telegrams arrival is not monitored.

1.5.207 Module Electronic CTS-01/06 > Channel 1: temperature control		
Device model	"Comfort" mode setpoint (°C)	25
Channel 1: general settings	"Standby" mode offset (°C)	0
Channel 1: temperature control	"Economy" mode offset (°C)	0
Channel 2: general settings	Action on reset	Restore previous mode
Channel 3: general settings	Controller direction	<input checked="" type="radio"/> Normal <input type="radio"/> Inverted
Channel 4: general settings	Controller type	<input type="radio"/> Cooler <input checked="" type="radio"/> Heater
Channel 5: general settings	Controller mode	2-points
Channel 6: general settings	Hysteresis (* 0,1 °C)	1
	Actuating command when sensor failure	Don't change
	Repeat actuating command periodically every (minutes, 0 - don't repeat)	0

Figure 7. Tab «Channel I: temperature control» in 2-points control mode

4.12 «COMFORT» MODE SETPOINT

The parameter allows to set the comfort mode setpoint (ref. to p.2.3 for more details).

Allowable values are +15.0 °C .. +35.0 °C, increment is 0.1 °C.

4.13 STANDBY MODE OFFSET

The parameter allows to set the offset of the actual setpoint in standby mode relative to the comfort mode setpoint. The actual setpoint changes to this value:

- increases, if parameter 4.17 «Controller type» is set to «Cooling»;
- decreases, if parameter 4.17 «Controller type» is set to «Heating».

Allowable values are 0 .. 25 °C, increment is 1 °C.

4.14 ECONOMY MODE OFFSET

The parameter allows to set the offset of the actual setpoint in economy mode relative to the comfort mode setpoint. The actual setpoint changes to this value:

- increases, if parameter 4.17 «Controller type» is set to «Cooling»;
- decreases, if parameter 4.17 «Controller type» is set to «Heating».

Allowable values are 0 .. 25 °C, increment is 1 °C.

4.15 ACTION ON RESET

The parameter allows to set the behavior of the device in the event of a reboot, power failure, and similar situations.

If «Restore previous mode» is selected, the device remembers the operating mode in non-volatile memory and after restoration of the supply voltage recovers in the same mode as before.

If «Set mode Comfort», «Set mode Standby» or «Set mode Economy» are selected, the device is forcibly switched to one of the above modes after the restoration of the supply voltage.

4.16 CONTROLLER DIRECTION

If «Normal» is selected, the device controls the actuator following the direct logic:

«0» - «Off», «1» - «On».

If «Inverted» is selected, the device controls the actuator following the inverse logic:

«1» - «Off», «0» - «On».

4.17 CONTROLLER TYPE

The parameter allows to set the controller operation mode: control of the cooling system or the heating system.

If «Cooler» is selected, the device controls the cooler:

- when the temperature rises above a setpoint value, it sends a control command «Switch on», when the temperature drops below - «Switch off»;
- offsets of the standby and economy modes setpoints are added to the comfort mode setpoint.

If «Heater» is selected, the device controls the heater:

- when the temperature drops below a setpoint value, it sends a control command «Switch on», when the temperature rises above - «Switch off»;
- offsets of the standby and economy modes setpoints are subtracted from the comfort mode setpoint.

Ref. to p.2.3 for more details.

4.18 CONTROLLER MODE

The parameter allows to set the type of control.

If «2-points» is selected, the controller operates in 2-point mode (ref. to p.2.4 for more details).

If «PI proportional» is selected, the controller operates in PI control mode, the control action is send via CommObject of 5.001 «Percentage» type . Ref. to p.2.5 for more details.

If «PI PWM» is selected, the controller operates in PI control mode, the control action is send in the form of a PWM signal via CommObject of 1.001 «On/Off» type.

Ref. to p.2.6 for more details.

4.19 HYSTERESIS

The parameter allows to set the hysteresis of the controller algorithm. Ref. to p.2.4 for more details.

The value is indicated in 1/10 °C.

The range of allowable values is 0..50 (0.0 °C.. 5.0 °C), increment is 0.1 °C.

4.20 ACTUATING COMMAND WHEN SENSOR FAILURE

This parameter allows to set the reaction of the device to a sensor failure:

- switch off;
- switch;
- don't change.

1.5.207 Module Electronic CTS-01/06 > Channel 1: temperature control		
Device model	"Comfort" mode setpoint (°C)	25
Channel 1: general settings	"Standby" mode offset (°C)	0
Channel 1: temperature control	"Economy" mode offset (°C)	0
Channel 2: general settings	Action on reset	Restore previous mode
Channel 3: general settings	Controller direction	<input checked="" type="radio"/> Normal <input type="radio"/> Inverted
Channel 4: general settings	Controller type	<input type="radio"/> Cooler <input checked="" type="radio"/> Heater
Channel 5: general settings	Controller mode	PI proportional
Channel 6: general settings	Heating system	Custom parameters
	Proportional range (°C)	4
	Integration period (minutes)	60
	Minimum actuating value (%)	10
	Maximum actuating value (%)	90
	Actuating value when sensor failure (%; -1 = don't change)	-1
	Repeat actuating command periodically every (minutes, 0 - don't repeat)	0

Figure 8. Tab «Channel 1: temperature control» in the PI proportional control mode

4.21 HEATING/COOLING SYSTEM

The parameter allows to choose from several typical presets of PI controller parameters or to set these parameters manually.

4.22 PROPORTIONAL RANGE, °C

The parameter allows to manually set the proportional coefficient of the PI controller.

The range of allowable values is 1..255 °C. Ref. to p.2.5.

4.23 INTEGRATION PERIOD, MINUTES

The parameter allows to manually set the integral coefficient of the PI controller.

The range of allowable values is 1..255 minutes. Ref. to p.2.5.

4.24 MINIMUM ACTUATING VALUE

The parameter allows to set the minimum actuating value of the PI controller.

The range is -0%.. 100%.

4.25 MAXIMUM ACTUATING VALUE

The parameter allows to set the maximum actuating value of the PI controller.

The range is -0%.. 100%.

4.26 ACTUATING VALUE WHEN SENSOR FAILURE

The parameter allows to set the actuating value of the PI controller in the event of a sensor failure.

The range is 0%.. 100%.

If «-1» is selected, the device will not react to a sensor failure.

1.5.207 Module Electronic CTS-01/06 > Channel 1: temperature control		
Device model	"Comfort" mode setpoint (°C)	25
Channel 1: general settings	"Standby" mode offset (°C)	0
Channel 1: temperature control	"Economy" mode offset (°C)	0
Channel 2: general settings	Action on reset	Restore previous mode
Channel 3: general settings	Controller direction	<input checked="" type="radio"/> Normal <input type="radio"/> Inverted
Channel 4: general settings	Controller type	<input type="radio"/> Cooler <input checked="" type="radio"/> Heater
Channel 5: general settings	Controller mode	PI PWM
Channel 6: general settings	Heating system	Custom parameters
	Proportional range (°C)	4
	Integration period (minutes)	60
	Minimum actuating value (%)	10
	Maximum actuating value (%)	90
	Actuating value when sensor failure (%; -1 = don't change)	-1
	PWM period (minutes)	1
	Repeat actuating command periodically every (minutes, 0 - don't repeat)	0

Figure 9. Tab «Channel 1: temperature control» in the PI control mode with PWM (PI PWM)

4.27 PWM PERIOD (MINUTES)

The parameter allows to set the period of the PWM signal of the controller.

The range of allowable values is 1..255 minutes. Ref. to p.2.6.

4.28 REPEAT ACTUATING COMMAND PERIODICALLY

Allows to set the frequency for repeated sending of control commands. The value is indicated in minutes, the range of possible values is 0 .. 60, increment is 1.

If the parameter is 0, a periodic repeat of control commands is not being done, and control commands are sent once if the state of the actuator is to be changed.

5 COMMUNICATION OBJECTS

Depending on the settings, the device activates and supports up to 14 independent CommObjects for each of the 6 channels.

Number ^	Name	Object Function	Description	Group Address	Length	C	R	W	T	U	Data Type	Priority
1	Channel 1	Current temperature			2 bytes	C	R	-	T	-	temperature (°C)	Low
7	Channel 1	External temperature			2 bytes	C	-	W	-	U	temperature (°C)	Low
13	Channel 1	Comfort setpoint			2 bytes	C	R	W	T	U	temperature (°C)	Low
19	Channel 1	Actual setpoint			2 bytes	C	R	-	T	-	temperature (°C)	Low
25	Channel 1	Comfort mode			1 bit	C	R	W	T	U	switch	Low
31	Channel 1	Standby mode			1 bit	C	R	W	T	U	switch	Low
37	Channel 1	Economy mode			1 bit	C	R	W	T	U	switch	Low
43	Channel 1	HVAC mode			1 byte	C	R	W	T	U	HVAC mode	Low
55	Channel 1	Controller on/off			1 bit	C	R	W	T	U	switch	Low
61	Channel 1	Actuating command (on/off)			1 bit	C	R	-	T	-	switch	Low
67	Channel 1	Actuating command (%)			1 byte	C	R	-	T	-	percentage (0..100%)	Low
73	Channel 1	Sensor alarm			1 bit	C	R	-	T	-	alarm	Low
79	Channel 1	Frost alarm			1 bit	C	R	-	T	-	alarm	Low
85	Channel 1	Heat alarm			1 bit	C	R	-	T	-	alarm	Low

Figure 10. Communication objects. The maximum set of objects for one channel (Channel 1) is shown

5.1 CURRENT TEMPERATURE

Allows reading the current temperature value. Also, through this object, the device automatically sends the current value (by timer or by change, if these modes are enabled in parameters 4.4 «Send actual temperature every» and/or 4.5 « Send actual temperature on change of»).

It becomes available when the «Internal» value of the parameter 4.2 «Sensor» is selected.

The object is read-only.

The data format is DPT 9.001 (16-bit numeric floating-point number, values are presented in 1/100 °C).

5.2 EXTERNAL TEMPERATURE

It is used to receive data from third-party devices that are able to measure temperature and send it via KNX bus.

It becomes available when the «External» value of the parameter 4.2 «Sensor» is selected.

The object is write-only.

The data format is DPT 9.001 (16-bit numeric floating-point number, values are presented in 1/100 °C).

5.3 COMFORT SETPOINT

Allows to set/read the value of the comfort mode setpoint. Ref. to p.2.3 for more details.

It becomes available when the «On» value of parameter 4.10 «Temperature control» is selected.

The object is writable and readable.

The data format is DPT 9.001 (16-bit numeric floating-point number, values are presented in 1/100 °C).

5.4 ACTUAL SETPOINT

Allows to read the actual value of the setpoint, taking into account the offset of the current mode. Ref. to p.2.3 for more details.

It becomes available when the «On» value of parameter 4.10 «Temperature control» is selected.

The object is read-only.

The data format is DPT 9.001 (16-bit numeric floating-point number, values are presented in 1/100 °C).

5.5 COMFORT MODE

Allows to switch the device to comfort mode.

It becomes available when the «On» value of parameter 4.10 «Temperature control» is selected.

The object is writable and readable.

The data format is DPT 1.001 (1-bit «On/Off» value).

5.6 STANDBY MODE

Allows to switch the device to standby mode.

It becomes available when the «On» value of parameter 4.10 «Temperature control» is selected.

The object is writable and readable.

The data format is DPT 1.001 (1-bit «On/Off» value).

5.7 ECONOMY MODE

Allows to switch the device to economy mode.

It becomes available when the «On» value of parameter 4.10 «Temperature control» is selected.

The object is writable and readable.

The data format is DPT 1.001 (1-bit «On/Off» value).

5.8 HVAC MODE

Allows to set/read the current operating mode of the device.

It becomes available when the «On» value of parameter 4.10 «Temperature control» is selected.

The object is writable and readable.

The data format is DPT 20.102 (8-bit value in the «HVAC» format (»Heating, Ventilation and Air Conditioning»): 1 - comfort mode, 2 - standby mode, 3 - economy mode, other values are not used and are ignored during recording.

5.9 CONTROLLER ON/OFF

It is used to turn on/off the controller (for example, during maintenance of the actuator). Similar to 4.10 «Temperature control» parameter .

When the value «On» is written to this object, the temperature is controlled in accordance with the settings.

When the value «Off» is written to this object, the temperature control is terminated; a command corresponding to the value of parameter 4.16 «Controller direction» is sent to the actuator via the object 5.10 «Actuating command».

The object is writable and readable.

The data format is DPT 1.001 (1-bit «On/Off» value).

5.10 ACTUATING COMMAND, ON/OFF

Used to send a command to turn on/off the actuator.

It becomes available when «On» is selected for 4.10 «Temperature control» parameter, if 4.18 «Controller mode» parameter is in the «2-points» or «PI PWM» position.

The object is read-only.

The data format is DPT 1.001 (1-bit “On/Off” value).

5.11 ACTUATING COMMAND, %

It is used to send a command to the actuator with proportional control.

It becomes available when «On» is selected for 4.10 «Temperature control» parameter, if 4.18 «Controller mode» parameter is in the «PI proportional» or «PI PWM» position.

The object is read-only.

The data format is DPT 5.001 (% 0 to 100).

5.12 SENSOR ALARM

It is used to alarm on the sensor failure.

It becomes available when «Send» is selected for 4.6 «Sensor failure alarm» parameter.

The object is read-only.

The data format is DPT 1.005 (1-bit «Alarm/No alarm» value).

5.13 FROST ALARM

It is used to alarm on overcooling.

It becomes available when the «Send» value of 4.7 «Heat/Frost alarms» parameter is selected.

The object is read-only.

The data format is DPT 1.005 (1-bit “Alarm/No alarm” value).

5.14 HEAT ALARM

It is used to alarm on overheating.

It becomes available when the «Send» value of 4.7 «Heat/Frost alarms» parameter is selected.

The object is read-only.

The data format is DPT 1.005 (1-bit «Alarm/No alarm» value).

6 DESCRIPTION OF BEHAVIOR OF THE DEVICE AFTER PROGRAMMING

After the initial loading of the software application the device is in the following state:

- all channels are inactive (parameters 4.1 «Channel activity» of all channels: in the «Inactive» position);
- all settings: default values.

7 DESCRIPTION OF BEHAVIOR OF THE DEVICE AFTER LOSS AND RETURN OF BUS VOLTAGE

In case of loss of communication with the KNX bus (when the voltage in the bus drops below the permissible level), the device stores in non-volatile memory the settings and current operating modes of all channels.

After restoration of the connection with the KNX bus (after restoration of the voltage in the bus in the allowable range), each channel switches to the mode set for it by the setting 4.15 over-cooling “Action on reset”: comfort mode, standby mode, economy mode, or the mode in which the channel was before the loss of communication with the KNX bus.