

**KXSK04RC-- Switching Actuator 4-fold**  
**KXSK08RC-- Switching Actuator 8-fold**  
**KXSK0CRC-- Switching Actuator 12-fold**

**Table of contents**

Use of the application program ..... 1

1. Functional description ..... 2

Behavior at bus voltage failure / recovery ..... 3

Building site function ..... 4

Factory default state ..... 4

Behavior on unloading the application program ..... 4

Resetting the device to factory default settings ..... 4

2. Communication objects ..... 5

3. Device Settings ..... 7

4. Channel settings (Switching) ..... 9

Control Value Input ..... 13

Normal mode ..... 17

Timer mode ..... 20

Flashing ..... 25

Logic operation ..... 28

Central switching ..... 30

8-bit scene control ..... 31

Night mode ..... 34

Override ..... 37

--- Manual override (ON) ..... 37

--- Permanent OFF ..... 40

--- Lock ..... 42

--- Central override control ..... 44

--- User-defined override function ..... 46

--- Forced control ..... 49

Status annunciation ..... 51

Counting of switching cycles ..... 53

Counting of operating hours ..... 56

**Use of the application program**

Application program „07 B0 A4 Switching Actuator 4-fold 9A0101“

Name: Switching Actuator N534D31  
 Description: Switching Actuator 4x AC 230V, 16/20AX, C-Load  
 Order no.: SWG1 534-1DB31

Application program „07 B0 A8 Switching Actuator 8-fold 9A0201“

Name: Switching Actuator N534D51  
 Description: Switching Actuator 8x AC 230V, 16/20AX, C-Load  
 Order no.: SWG1 534-1DB51

Application program „07 B0 A12 Switching Actuator 12-fold 9A0301“

Name: Switching Actuator N534D61  
 Description: Switching Actuator 12x AC 230V, 16/20AX, C-Load  
 Order no.: SWG1 534-1DB61

## Application program description

February 2019

**KXSK04RC-- Switching Actuator 4-fold**  
**KXSK08RC-- Switching Actuator 8-fold**  
**KXSK0CRC-- Switching Actuator 12-fold**

### 1. Functional description

The application program “07 B0 A4 Switching Actuator 4-fold 9A0101”, „07 B0 A8 Switching Actuator 8-fold 9A0201“ and „07 B0 A12 Switching Actuator 12-fold 9A0301“ can be used for the KNX devices listed in section “Use of the application program”. These devices are briefly described in the next sections.

The Switching actuators N530D31, N532D31 and N534D31 are KNX devices with four switching outputs. The switching actuators are DIN rail mounted devices designed for installation in distribution boards and control cabinets. The bus is connected via a bus terminal block. The actuator electronics are supplied via the bus voltage.

The Switching actuators N530D51, N532D51 and N534D51 are KNX devices with eight switching outputs. The switching actuators are DIN rail mounted devices designed for installation in distribution boards and control cabinets. The bus is connected via a bus terminal block. The actuator electronics are supplied via the bus voltage.

The Switching actuators N530D61, N532D61 and N534D61 are KNX devices with twelve switching outputs. The switching actuators are DIN rail mounted devices designed for installation in distribution boards and control cabinets. The bus is connected via a bus terminal block. The actuator electronics are supplied via the bus voltage.

These devices share the following features.

The device can switch resistive loads (e.g. electrical heaters, incandescent lamps, high voltage halogen lamps), inductive loads (e.g. motor, low voltage halogen lamps with intermediate conventional transformers), or capacitive loads (e.g. low voltage halogen lamps with intermediate electronic transformers).

Dependent on the configuration each actuator output provides switching, logic control, central switching 8-bit scene control, timer functions and switching status annunciation.

As an alternative to the switching input a control value input with configurable threshold value for switching on and off can be selected.

The output of the actuator may be set to one of the following operation modes:

- Normal operation
- Timer operation
- Flashing

In the operation mode “Normal operation”, delayed on and off switching as well as timer night mode are available as timer functions.

In the operation mode “Timer operation”, the functions timer day time and timer night mode are available.

In the operation mode “Flashing”, the output is cyclically switched on and off with configurable on and off switching periods.

In timer day time and timer night mode time limited on switching (e.g. for cleaning illumination) can be activated, if needed with warning before switching off via off and on switching of the output (single flashing).

Up to six different override function blocks and forced control can be activated for overriding automation functions. For each override function block one of these functions can be selected: Manual ON, Permanent OFF, Blocking function, central override, and user-defined override function. For each actuator output this allows for flexible configuration of different priority dependent overrides. For the override functions a control value input can be selected instead of a switching input.

The application program includes per output the options for counting of switching cycles and operating hours both without or with threshold monitoring as well as an integrated 8-bit scene, in which the output can be incorporated into up to 8 scenes.

The following schema shows the named features in a logical overview.

KXSK04RC-- Switching Actuator 4-fold  
 KXSK08RC-- Switching Actuator 8-fold  
 KXSK0CRC-- Switching Actuator 12-fold

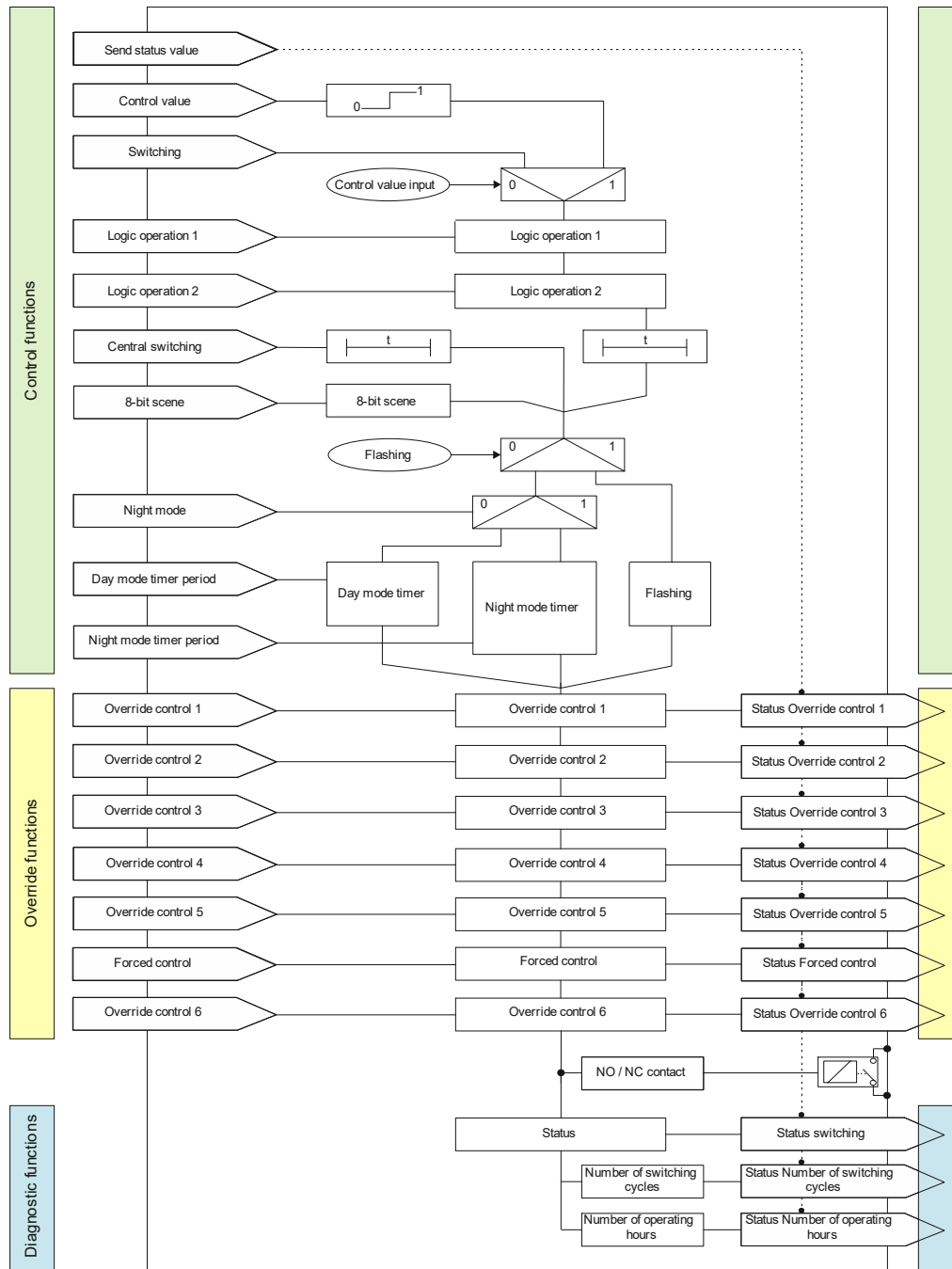

Schematic design of a switching actuator channel

**Behavior at bus voltage failure / recovery**

Because the device electronics are powered by bus voltage a mains power failure only leads to a functional failure of the actuator if the bus voltage fails due to a failure of the mains voltage.

## Application program description

February 2019

**KXSK04RC-- Switching Actuator 4-fold**  
**KXSK08RC-- Switching Actuator 8-fold**  
**KXSK0CRC-- Switching Actuator 12-fold**

For each actuator output the switching position of the relay on bus voltage failure can be individually configured to be Off, On, or with No change.

On bus voltage failure the current switching status value and further values of each output are saved permanently for restoration on bus voltage recovery.

On bus voltage recovery, the starting value of the switching object can be set to Off, On, last switching status or last received value.

On bus voltage recovery the configured actions are executed and, if applicable, new status values are reported.

### Building site function

The building site function provided ex-factory enables switching the building site lighting on and off via bus wall switches and actuators, even if these devices have not yet been commissioned with ETS.

### Factory default state

In the default factory state all channels (outputs) are set to the function "switching" for the building site function.

### Behavior on unloading the application program

When the application program is unloaded with ETS the device does not function.

### Resetting the device to factory default settings

A very long push of the programming button (> 20 s) effects a reset to factory settings. This is indicated by constant flashing for 8 seconds.

All configuration settings are lost. The building site function is re-activated.

### Addressing mode

A short push of learning button (< 2 s) enables the addressing mode. This is indicated by a continuously lit programming mode LED. A second push disables this mode.

KXSK04RC-- Switching Actuator 4-fold  
 KXSK08RC-- Switching Actuator 8-fold  
 KXSK0CRC-- Switching Actuator 12-fold

## 2. Communication objects

Maximum number of group addresses: 2000  
 Maximum number of assignments: 2000

### Note

The number and names of communication objects visible in the ETS menu can vary depending on the parameter settings.

The application program already has been loaded in the factory.

The device is configured and commissioned with Engineering Tool Software (ETS) version ETS v4.2 or higher.

With the ETS (Engineering Tool Software) the specific parameters and addresses are assigned appropriately, and downloaded into the device.

The following list shows all objects of the device. Which objects are visible and linkable to group addresses is defined via the functions assigned to the inputs.

The objects and associated parameter settings are described with the functions.

No.	Object name	Function	Number of bits	Flags
1	Status device function	ok / defect	1 Bit	CRT
2	Send status values	request	1 Bit	CW
3	A Switching	ON / OFF	1 Bit	CW
4	A Control value	Value	1 Byte (Percent 0 ... 100%) (DPT5.001) 1 Byte (Count pulses 0 ... 255) (DPT5.010) 2 Byte (Temperature °C) (DPT 9.001) 2 Byte (Illuminance lx) (DPT 9.004) 2 Byte (Current mA) (DPT 9.021) 4 Byte (Power W) (DPT14.056) 2 Byte (Power kW) (DPT 9.024)	CW
5	A Status switching	ON / OFF	1 Bit	CRT
6	A Logic operation 1	ON / OFF	1 Bit	CW
7	A Logic operation 2	ON / OFF	1 Bit	CW
8	A Central switching	ON / OFF	1 Bit	CW
9	A 8-bit scene	recall / store	1 Byte	CW
10	A Night mode	ON / OFF	1 Bit	CW
11	A Night mode timer	ON time (seconds)	2 Bytes	CRW
12	A Day mode timer	ON time (seconds)	2 Bytes	CRW
13	A Forced control	ON / OFF	2 Bit	CW
14	A Pre-warning expiration of timer period	ON / OFF	1 Bit	CRT
15	A Lock timer	ON / OFF	1 Bit	CW
16	A Override 1, Manual ON	ON / OFF	1 Bit	CW
17	A Override 1, Manual ON, Control value	Control value	1 Byte (Percent 0 ... 100%) (DPT5.001) 1 Byte (Count pulses 0 ... 255) (DPT5.010) 2 Byte (Temperature °C) (DPT 9.001) 2 Byte (Illuminance lx) (DPT 9.004) 2 Byte (Current mA) (DPT 9.021) 4 Byte (Power W) (DPT14.056) 2 Byte (Power kW) (DPT 9.024)	CW
18	A Override 1, Manual ON, Status	ON / OFF	1 Bit	CRT
19	A Override 2, Permanent-OFF	ON / OFF	1 Bit	CW
20	A Override 2, Permanent-OFF, Control value	Value	1 Byte (Percent 0 ... 100%) (DPT5.001) 1 Byte (Count pulses 0 ... 255) (DPT5.010) 2 Byte (Temperature °C) (DPT 9.001) 2 Byte (Illuminance lx) (DPT 9.004) 2 Byte (Current mA) (DPT 9.021) 4 Byte (Power W) (DPT14.056) 2 Byte (Power kW) (DPT 9.024)	CW
21	A Override 2, Permanent-OFF, Status	ON / OFF	1 Bit	CRT
22	A Override 3, Lock	ON / OFF	1 Bit	CW
23	A Override 3, Lock, Control value	Value	1 Byte (Percent 0 ... 100%) (DPT5.001) 1 Byte (Count pulses 0 ... 255) (DPT5.010) 2 Byte (Temperature °C) (DPT 9.001) 2 Byte (Illuminance lx) (DPT 9.004) 2 Byte (Current mA) (DPT 9.021) 4 Byte (Power W) (DPT14.056) 2 Byte (Power kW) (DPT 9.024)	CW
24	A Override 3, Lock, Status	ON / OFF	1 Bit	CRT
25	A Override 4, Central control	ON / OFF	1 Bit	CW
26	A Override 4, Central control, Control value	Value	1 Byte (Percent 0 ... 100%) (DPT5.001) 1 Byte (Count pulses 0 ... 255) (DPT5.010)	CW

## Application program description

February 2019

**KXSK04RC-- Switching Actuator 4-fold**  
**KXSK08RC-- Switching Actuator 8-fold**  
**KXSK0CRC-- Switching Actuator 12-fold**

No.	Object name	Function	Number of bits	Flags
			2 Byte (Temperature °C) (DPT 9.001) 2 Byte (Illuminance lx) (DPT 9.004) 2 Byte (Current mA) (DPT 9.021) 4 Byte (Power W) (DPT14.056) 2 Byte (Power kW) (DPT 9.024)	
27	A Override 4, Central control, Status	ON / OFF	1 Bit	CRT
28	A Override 5, User-defined Control	ON / OFF	1 Bit	CW
29	A Override 5, User-defined Control, Control value	Value	1 Byte (Percent 0 ... 100%) (DPT5.001) 1 Byte (Count pulses 0 ... 255) (DPT5.010) 2 Byte (Temperature °C) (DPT 9.001) 2 Byte (Illuminance lx) (DPT 9.004) 2 Byte (Current mA) (DPT 9.021) 4 Byte (Power W) (DPT14.056) 2 Byte (Power kW) (DPT 9.024)	CW
30	A Override 5, User-defined Control, Status	ON / OFF	1 Bit	CRT
31	A Override 6, User-defined Control	ON / OFF	1 Bit	CW
32	A Override 6, User-defined Control, Control value	Value	1 Byte (Percent 0 ... 100%) (DPT5.001) 1 Byte (Count pulses 0 ... 255) (DPT5.010) 2 Byte (Temperature °C) (DPT 9.001) 2 Byte (Illuminance lx) (DPT 9.004) 2 Byte (Current mA) (DPT 9.021) 4 Byte (Power W) (DPT14.056) 2 Byte (Power kW) (DPT 9.024)	CW
33	A Override 6, User-defined Control, Status	ON / OFF	1 Bit	CRT
34	A Number of switching cycles	Value	4 Byte	CRT
35	A Number of switching cycles	Set Value	4 Byte	CW
36	A Threshold for switching cycles	Set Value	4 Byte	CRW
37	A Exceedance of threshold for switching cycles	ON / OFF	1 Bit	CRT
38	A Operating hours	Value	4 Byte	CRT
39	A Operating hours	Value (in seconds)	4 Byte	CRT
40	A Operating hours	Set Value	4 Byte	CW
41	A Threshold for switching cycles	Set Value	4 Byte	CRW
42	A Exceedance of threshold for switching cycles	ON / OFF	1 Bit	CRT

**KXSK04RC-- Switching Actuator 4-fold**  
**KXSK08RC-- Switching Actuator 8-fold**  
**KXSK0CRC-- Switching Actuator 12-fold**

### 3. Device Settings

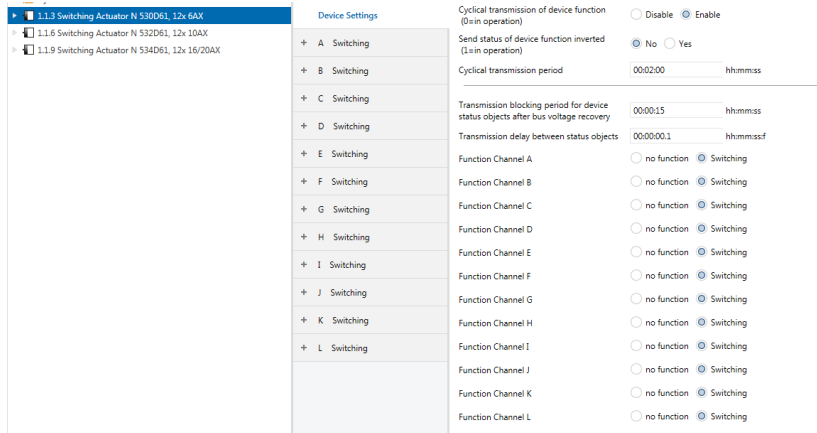

In this parameter window those settings are determined which span across channels and functions. Additionally, in this parameter window the function of the respective channels is selected. The function for channel A-D, A-H or A-L is configured in the same manner and thus is only described once for channel A.

#### Objects

Obj	Object name	Function	Type	Flag
1	Status device function	ok / defect	1 Bit	CRT
<p>The value "0" is regularly sent via this object when the device is in operation. If the device does not send cyclically anymore, then this indicates a device failure. Only in case of a malfunction, which can be detected by the device itself, will it send the value "1".</p> <p>Via a parameter the status of the device function can be sent as an inverted value. Then on normal operation the device will cyclically send the value "1". Only in case of a malfunction, which can be detected by the device itself, will it send the value "0".</p> <p>A supervisory system may monitor the cyclical sending and initiate e.g. a warning or alarm message on missing the status message.</p> <p>Note:</p> <p>A malfunction may be a failure of a part of the hardware, which is required for the proper function of the device or individual channels, but does not lead to failure of the device communication, as is the case on bus voltage failure. A malfunction may be present, if e.g. necessary calibrations cannot be performed and the device cannot function properly or not at all.</p>				
2	Send status values	Request	1 Bit	CW
<p>When a telegram with any value ("1" or "0") is received via this object then sending of the current status values for all those status objects is triggered, for which "sending on request" for the status object is enabled.</p>				

#### Parameter „Device Settings“

Parameter	Settings
<b>Cyclical transmission of device function (0=in operation)</b>	Disable; <b>Enable</b>
<p>Via this parameter, cyclical sending of the device function can be enabled or disabled.</p> <p>During normal operation of the device the value "0" is sent cyclically.</p>	

**Application program description**

February 2019

<p><b>KXSK04RC-- Switching Actuator 4-fold</b>  <b>KXSK08RC-- Switching Actuator 8-fold</b>  <b>KXSK0CRC-- Switching Actuator 12-fold</b></p>
---

Parameter	Settings
<p><b>Send status of device function inverted (1= in operation)</b></p>	<p><b>No;</b> Yes</p>
<p><i>This parameter is only visible, when the parameter "cyclical transmission of the device function" is set to "Enable".</i>                      This parameter determines sending of the inverted status value of the device function.                      During normal operation of the device the value "1" is sent cyclically.</p>	
<p><b>Cyclical transmission period (hh:mm:ss)</b></p>	<p><b>00:02:00;</b> [00:00:01...18:12:15]</p>
<p><i>This parameter is only visible, when the parameter "cyclical transmission of the device function" is set to "Enable".</i>                      This parameter determines the period for cyclical sending of the device function.</p>	
<p><b>Transmission blocking period for device status objects after bus voltage recovery (hh:mm:ss)</b></p>	<p><b>00:00:15</b> [00:00:00...18:12:15]</p>
<p>This parameter ensures that there is no unnecessary bus load due to status telegrams immediately after bus voltage recovery or a restart of the device.                      The length of the sending delay is dependent on the individual address.                      The transmission blocking period must be set to such a value that other KNX devices, which shall receive and process the status, have already finalized their initialization.  <i>Note: This transmission blocking period does not apply when status values are sent on request. The transmission blocking period applies to the saved status values after bus voltage recovery. If the status changes during the transmission blocking period (e.g. due to switching), then the respective status is sent immediately and is not sent again after the transmission blocking period has expired.</i></p>	
<p><b>Transmission delay between status objects (hh:mm:ss,f)</b></p>	<p><b>00:00:00,1</b> [00:00:00,1...00:01:00,0]</p>
<p>This parameter determines the required transmission delay between two consecutive status telegrams to avoid generating unnecessary bus load during operation due to status telegrams sent immediately after one another.  <i>Note: This transmission delay only applies after bus voltage recovery and for the function "send status values".</i></p>	
<p><b>Function Channel A (B, C, D)</b></p>	<p>No function; <b>Switching</b></p>
<p>This parameter determines the function of channel A.                      With the setting "no function" there is no parameter window and objects for this channel.                      When the function "switching" is selected then the parameter window "Switching" for the channel appears</p>	

KXSK04RC-- Switching Actuator 4-fold  
 KXSK08RC-- Switching Actuator 8-fold  
 KXSK0CRC-- Switching Actuator 12-fold

#### 4. Channel settings (Switching)

The objects and parameters are configured the same for all channels. Hence, this is described only once for channel A. Each actuator output can be configured with the following partial functions:

- Control Value Input
- Switching (Normal mode)
- Switching (Timer mode)
- Flashing
- Logic operations
- Central switching
- 8-bit scene control
- Night mode
- Override
  - Manual override
  - Permanent OFF
  - Lock
  - Central override control
  - User-defined Control
  - Forced Control
- Status annunciation
- Number of switching cycles with or without threshold monitoring
- Number of operating hours with or without threshold monitoring

Except for the parameter windows for the operation mode dependent settings and the logical gates, all other parameter windows appear only after specific parameter selection in the parameter window "Functions, objects".

The parameter window "Functions, objects" is always described before the specific parameter window.

The following sections describe the functions, which can be configured for the channel, including the associated objects and parameter settings.

#### Note

## Application program description

February 2019

**KXSK04RC-- Switching Actuator 4-fold**  
**KXSK08RC-- Switching Actuator 8-fold**  
**KXSK0CRC-- Switching Actuator 12-fold**

The number and names of the parameter windows in the ETS menus may vary as they are controlled via parameter settings. Another parameter window may appear if due to dynamically added parameters the space in the first parameter window is exhausted.

### Functions, Objects

The screenshot shows the 'Device Settings' window for a switching actuator. The left sidebar lists three actuator models: 1.1.3 Switching Actuator N 530D61, 12x 6AX; 1.1.6 Switching Actuator N 532D61, 12x 10AX; and 1.1.9 Switching Actuator N 534D61, 12x 16/20AX. The main area is titled 'A Switching' and contains a sub-section 'Functions, objects'. This section includes 'Normal mode' and 'Logic operations'. The 'Logic operations' section is expanded, showing various parameters:

- Operation Mode: Normal mode (dropdown)
- Relay mode:  Normally Open  Normally Closed
- Control Value Input:  Disable  Enable
- Central Switching:  Disable  Enable
- 8-bit scene control:  Disable  Enable
- Forced control:  Disable  Enable
- Override 1: deactivated (dropdown)
- Override 2: deactivated (dropdown)
- Override 3: deactivated (dropdown)
- Override 4: deactivated (dropdown)
- Override 5: deactivated (dropdown)
- Override 6: deactivated (dropdown)
- Status object:  Disable  Enable
- Send status on request:  Disable  Enable
- Send status on change of status:  Disable  Enable
- send status cyclically: 00:00:00 hummss
- Switching state on bus voltage failure: no change (dropdown)
- Initial value of switching object after bus voltage recovery: last status value (dropdown)
- Counting of switching cycles:  Disable  Enable
- Counting of operating hours:  Disable  Enable

In this section only those parameters are described that do not activate further parameter windows or have further parameters appear in a following parameter window.

Parameters, which activate a further parameter window or have further parameters appear in a following parameter window, are described in the respective section.

### Parameter „Functions, Objects“



## Application program description

February 2019

KXSK04RC-- Switching Actuator 4-fold  
KXSK08RC-- Switching Actuator 8-fold  
KXSK0CRC-- Switching Actuator 12-fold

Parameter	Settings
	On; <b>Last status value;</b> Last value received
This parameter determines the starting value of the switching object after bus voltage recovery. Last status value: The initial value is set to the status value of the channel on bus voltage failure. Last value received: The initial value is set to the value of the switching object on bus voltage failure. <i>Note: Dependent on the configuration the switching state of the output may change against the switching state on bus voltage failure.</i>	

Further parameter settings are described in these sections:

- Control Value Input
- Switching (Normal mode)
- Switching (Timer mode)
- Flashing
- Logic operation
- Central switching
- 8-bit scene control
- Night mode
- Manual override (ON)
- Permanent OFF
- Lock
- Central override
- User-defined Control
- Forced control
- Status annunciation
- Counting of switching cycles
- Counting of operating hours

**KXSK04RC-- Switching Actuator 4-fold**  
**KXSK08RC-- Switching Actuator 8-fold**  
**KXSK0CRC-- Switching Actuator 12-fold**

**Control Value Input**

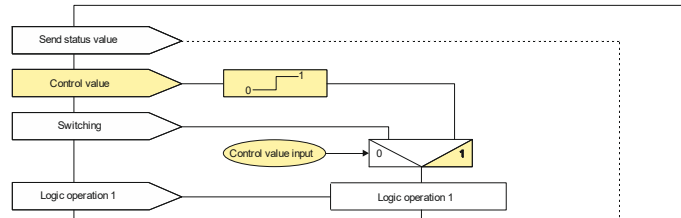

Function Control Value Input

For each channel, there is a control value input as an alternative to the switching input. Via this control value input analog values can be transposed into On respectively Off commands. Percentage values, integers (0...255), temperature in °C (DPT 9.001), illuminance in lux (DPT 9.004), current in mA (DPT 9.021) and power in W (DPT 14.056) or kW (DPT 9.024) can be used.

Also for the override functions instead of the switching input a control value input can be used with the corresponding object. The available parameter settings are the same. Hence, the parameter descriptions are the same.

Objects

Obj	Object name	Function	Type	Flag
4	A Control value	Value	1 Byte (Percent 0 ... 100%) (DPT5.001) 1 Byte (Count pulses 0 ... 255) (DPT5.010) 2 Byte (Temperature °C) (DPT 9.001) 2 Byte (Illuminance lx) (DPT 9.004) 2 Byte (Current mA) (DPT 9.021) 4 Byte (Power W) (DPT14.056) 2 Byte (Power kW) (DPT 9.024)	CW
The control value telegrams for the channel are received via this object in normal or timer operation mode. A received control value is transformed into a switching signal via a threshold evaluation. Format and data point type of the object are determined via the parameter "Data Type".				
16	A Override 1, Manual ON, Control value	Value	1 Byte (Percent 0 ... 100%) (DPT5.001) 1 Byte (Count pulses 0 ... 255) (DPT5.010) 2 Byte (Temperature °C) (DPT 9.001) 2 Byte (Illuminance lx) (DPT 9.004) 2 Byte (Current mA) (DPT 9.021) 4 Byte (Power W) (DPT14.056) 2 Byte (Power kW) (DPT 9.024)	CW
The control value telegrams for the override 1 (here: Manual ON) are received via this object. A received control value is transformed into a switching signal via a threshold evaluation. Format and data point type of the object are determined via the parameter "Data Type".				
19	A Override 2, Permanent OFF, Control value	Value	1 Byte (Percent 0 ... 100%) (DPT5.001) 1 Byte (Count pulses 0 ... 255) (DPT5.010) 2 Byte (Temperature °C) (DPT 9.001) 2 Byte (Illuminance lx) (DPT 9.004) 2 Byte (Current mA) (DPT 9.021) 4 Byte (Power W) (DPT14.056) 2 Byte (Power kW) (DPT 9.024)	CW
The control value telegrams for the override 2 (here: Permanent OFF) are received via this object. A received control value is transformed into a switching signal via a threshold evaluation.				

**Application program description**

February 2019

**KXSK04RC-- Switching Actuator 4-fold**  
**KXSK08RC-- Switching Actuator 8-fold**  
**KXSK0CRC-- Switching Actuator 12-fold**

Obj	Object name	Function	Type	Flag
Format and data point type of the object are determined via the parameter "Data Type".				
22	A Override 3, Lock, Control value	Value	1 Byte (Percent 0 ... 100%) (DPT5.001) 1 Byte (Count pulses 0 ... 255) (DPT5.010) 2 Byte (Temperature °C) (DPT 9.001) 2 Byte (Illuminance lx) (DPT 9.004) 2 Byte (Current mA) (DPT 9.021) 4 Byte (Power W) (DPT14.056) 2 Byte (Power kW) (DPT 9.024)	CW
The control value telegrams for the override 3 (here: Lock) are received via this object. A received control value is transformed into a switching signal via a threshold evaluation. Format and data point type of the object are determined via the parameter "Data Type".				
25	A Override 4, Central, Control value	Value	1 Byte (Percent 0 ... 100%) (DPT5.001) 1 Byte (Count pulses 0 ... 255) (DPT5.010) 2 Byte (Temperature °C) (DPT 9.001) 2 Byte (Illuminance lx) (DPT 9.004) 2 Byte (Current mA) (DPT 9.021) 4 Byte (Power W) (DPT14.056) 2 Byte (Power kW) (DPT 9.024)	CW
The control value telegrams for the override 4 (here: Central) are received via this object. A received control value is transformed into a switching signal via a threshold evaluation. Format and data point type of the object are determined via the parameter "Data Type".				
28	A Override 5, User-defined Control, Control value	Value	1 Byte (Percent 0 ... 100%) (DPT5.001) 1 Byte (Count pulses 0 ... 255) (DPT5.010) 2 Byte (Temperature °C) (DPT 9.001) 2 Byte (Illuminance lx) (DPT 9.004) 2 Byte (Current mA) (DPT 9.021) 4 Byte (Power W) (DPT14.056) 2 Byte (Power kW) (DPT 9.024)	CW
The control value telegrams for the override 5 (here: User-defined) are received via this object. A received control value is transformed into a switching signal via a threshold evaluation. Format and data point type of the object are determined via the parameter "Data Type".				
32	A Override 6, User-defined Control, Control value	Value	1 Byte (Percent 0 ... 100%) (DPT5.001) 1 Byte (Count pulses 0 ... 255) (DPT5.010) 2 Byte (Temperature °C) (DPT 9.001) 2 Byte (Illuminance lx) (DPT 9.004) 2 Byte (Current mA) (DPT 9.021) 4 Byte (Power W) (DPT14.056) 2 Byte (Power kW) (DPT 9.024)	CW
The control value telegrams for the override 6 (here: User-defined) are received via this object. A received control value is transformed into a switching signal via a threshold evaluation. Format and data point type of the object are determined via the parameter "Data Type".				

Parameter „Functions, Objects“

**KXSK04RC-- Switching Actuator 4-fold**  
**KXSK08RC-- Switching Actuator 8-fold**  
**KXSK0CRC-- Switching Actuator 12-fold**

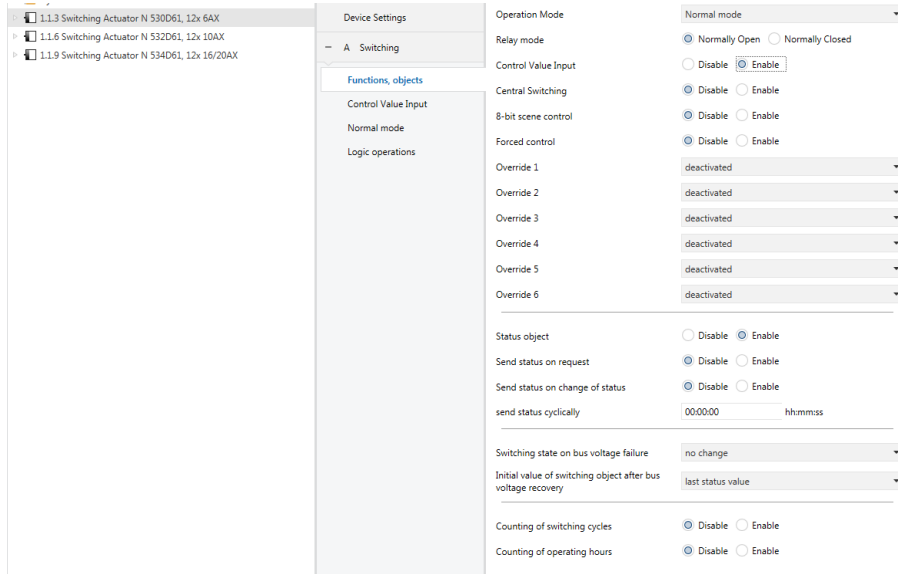

Parameter	Settings
<b>Control Value Input</b>	<b>Disable;</b> <b>Enable</b>
This parameter determines if the object "Control Value" for the channel and the associated parameters are visible. The switching input is invisible as long as the control value input is visible.	

Parameter „Control Value Input“

**Note**

For the override functions, the same parameters are used for their selectable control value input and thus are only described once in this section.

## Application program description

February 2019

KXSK04RC-- Switching Actuator 4-fold  
KXSK08RC-- Switching Actuator 8-fold  
KXSK0CRC-- Switching Actuator 12-fold

Parameter	Settings
<b>Data Type</b>	<b>Percentage (%)</b> ; Value (8-bit); Temperature (°C); Illuminance (lx); Current (mA); Power (kW); Power (W)
This parameter determines the data type of the communication object. The selectable data point types are: 1 Byte (Percent 0 ... 100%) (DPT5.001) 1 Byte (Count pulses 0 ... 255) (DPT5.010) 2 Byte (Temperature °C) (DPT 9.001) 2 Byte (Illuminance lx) (DPT 9.004) 2 Byte (Current mA) (DPT 9.021) 4 Byte (Power W) (DPT14.056) 2 Byte (Power kW) (DPT 9.024)	
<b>Threshold for Off (&lt;=)</b>	<b>0</b>
This parameter determines the threshold for Off. If the value is lower than or equal to the configured threshold for Off, then the resulting switching value is "Off" (0). The valid values for the threshold are dependent on the selected data type. <i>Note:</i> <i>If both threshold values are identical then on reception of exactly this value then it is interpreted as threshold value for „On“.</i>	
<b>Threshold for On (&gt;=)</b>	<b>1</b>
This parameter determines the threshold for On. If the value is higher than or equal to the configured threshold for On, then the resulting switching value is "On" (1). The valid values for the threshold are dependent on the selected data type.	

### Note

If the „Threshold for Off (<=)“ is selected to be higher than the „Threshold for On (>=)“ then the higher value is used as „Threshold for On (>=)“.

**KXSK04RC-- Switching Actuator 4-fold**  
**KXSK08RC-- Switching Actuator 8-fold**  
**KXSK0CRC-- Switching Actuator 12-fold**

**Normal mode**

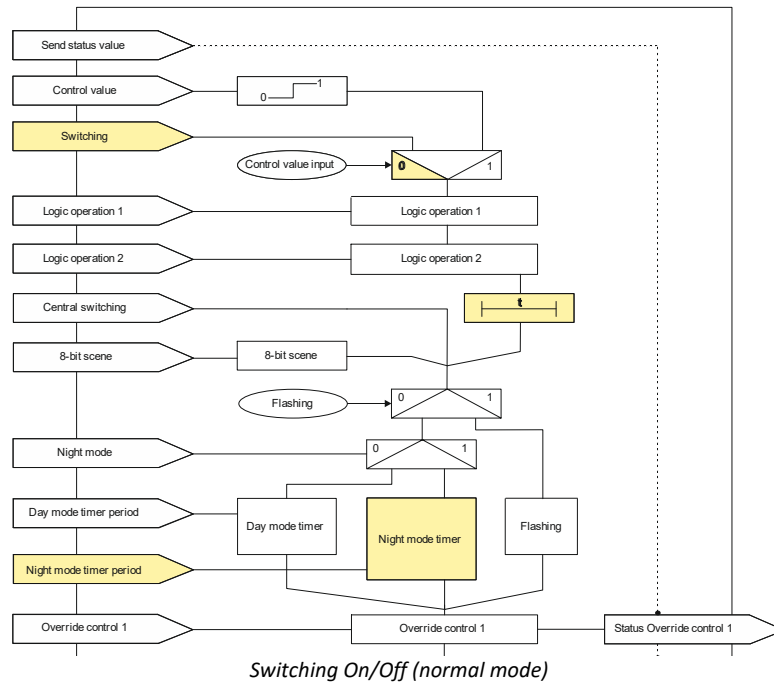

Objects

Obj	Object name	Function	Type	Flag
3	A Switching	ON / OFF	1 Bit	CW
Via this object switching telegrams are received in normal or timer mode as well as flashing mode. Note: As alternative to the switching input a control value input can be used.				

## Application program description

February 2019

**KXSK04RC-- Switching Actuator 4-fold**  
**KXSK08RC-- Switching Actuator 8-fold**  
**KXSK0CRC-- Switching Actuator 12-fold**

### Parameter „Functions, Objects“

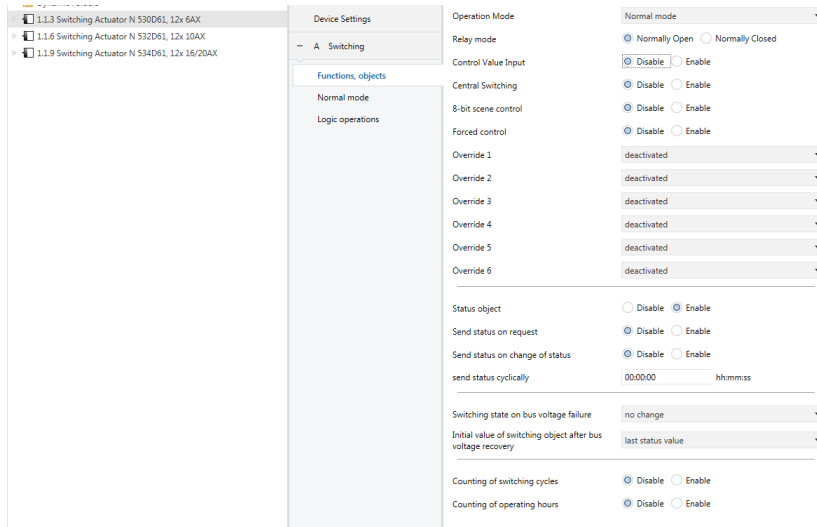

This parameter window offers selection of the base function (normal mode / timer mode/ flashing) and of further functions of this actuator output channel. This includes,

- whether the output operates as normally open or normally closed contact,
- whether a control value input shall be used instead of a switching input,
- whether central switching shall be added,
- whether an 8-bit scene control shall be added,
- whether a status object shall be added for this output channel,
- whether a permanent or time-limited manual override to On shall be possible,
- whether the output shall be turned of permanently by an override,
- whether forced control has to be provided,
- which switching status the output shall take on bus voltage failure and which value the switching object, and where applicable the logic object shall take on bus voltage recovery,
- whether the switching cycles of this output channel shall be counted with or without an upper threshold,
- whether the operating hours for this output channel shall be counted with or without an upper threshold.

Parameter	Settings
<b>Operation mode</b>	<b>Normal mode;</b> Timer mode; Flashing
This parameter determines whether the respective output works as a “normal” maintained switch or as a timer or whether it is flashing. In the further description, the timer mode is referred to as “timer day mode” to have a distinction to the “night mode”, which can be enabled additionally.	

The parameter “Operation mode” is set to “Normal mode”.

The other parameters are covered in the sections

**KXSK04RC-- Switching Actuator 4-fold**  
**KXSK08RC-- Switching Actuator 8-fold**  
**KXSK0CRC-- Switching Actuator 12-fold**

- Control Value Input
- Central switching
- 8-bit scene control
- Manual override (ON)
- Permanent OFF
- Lock
- Central override
- User-defined Control
- Forced control
- Status annunciation
- Counting of switching cycles
- Counting of operating hours

Parameter „Normal mode“

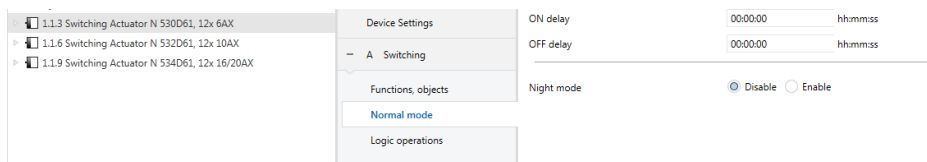

This parameter window is used to set the switching behavior in "Normal mode" of the corresponding actuator output channel.

The parameter window for the output channel is used to set

- whether an "on" delay shall be executed and how long the period for the on delay is,
- whether an "off" delay shall be executed and how long the period for the off delay is,
- whether night mode with a time- controlled "On" period is desired, and how long the "On" period is,
- whether in night mode a warning before switching off shall be executed.

Parameter	Settings
<b>ON delay</b> [hh:mm:ss]	<b>00:00:00</b> [00:00:00...23:59:59]
This parameter sets the wanted on-delay time. The default value 00:00:00 means that ON commands are executed immediately. A set on-delay acts on the "Switching" object and on an object for a logic operation allocated to the output as well.	
<b>OFF delay</b> [hh:mm:ss]	<b>00:00:00</b> [00:00:00...23:59:59]
This parameter sets the wanted off-delay time. The default value 00:00:00 means that OFF commands are executed immediately. A set off-delay acts on the "Switching" object and on an object for a logic operation allocated to the output as well.	

The other parameters are covered in the sections

- Night mode.

## Application program description

February 2019

**KXSK04RC-- Switching Actuator 4-fold**  
**KXSK08RC-- Switching Actuator 8-fold**  
**KXSK0CRC-- Switching Actuator 12-fold**

### Timer mode

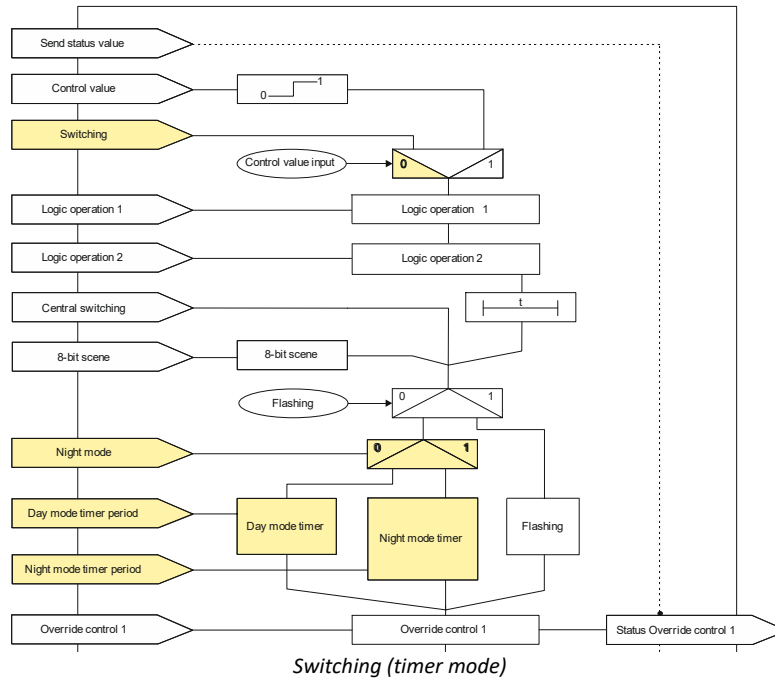

### Objects

Obj	Object name	Function	Type	Flag
3	A Switching	ON / OFF	1 Bit	CRT
Via this object switching telegrams are received in normal or timer modes. These telegrams are forwarded where necessary to the corresponding output via the timer function. If a logic operation is configured in normal or timer mode, then the result of the timer function is the 1st value for the logic combination for the corresponding output.				
12	A Day mode timer	ON time(seconds)	2 Bytes	CRW
Via this object telegrams for setting the timer period in day mode are received in timer operation mode. This allows for adjusting the timer period during operation.				
14	A Pre-warning expiration of timer period	ON / OFF	1 Bit	CRT
Via this object the expiration of the timer period in timer operation mode is signaled. This can be used to e.g. switch on a warning lamp.				
15	A Lock timer	ON / OFF	1 Bit	CW
Via this object the timer function in day and night mode for the output can be stopped, restarted, locked respectively unlocked in timer operation mode. This allows for switching the timer operation off when this is required.				

**KXSK04RC-- Switching Actuator 4-fold**  
**KXSK08RC-- Switching Actuator 8-fold**  
**KXSK0CRC-- Switching Actuator 12-fold**

Parameter „Functions, Objects“

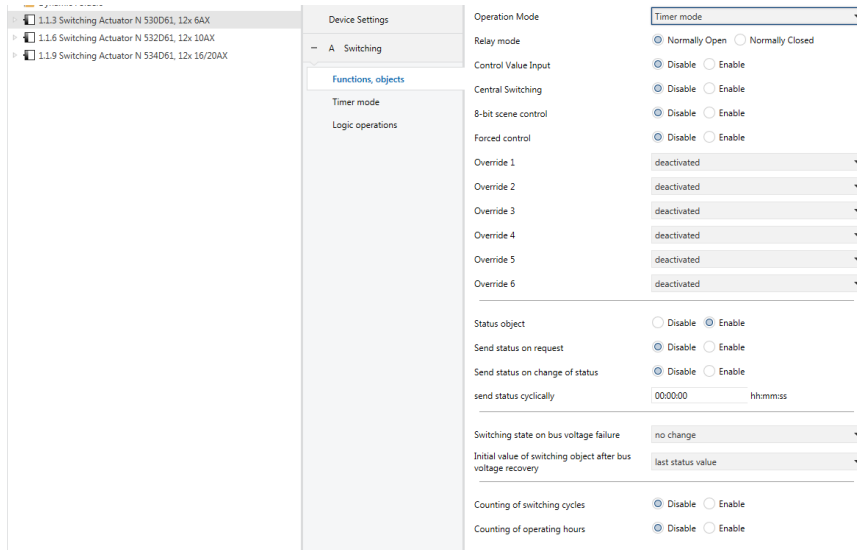

This parameter window offers selection of the base function (normal mode / timer mode/ flashing) and of further functions of this actuator output channel. This includes,

- whether the output operates as normally open or normally closed contact,
- whether a control value input shall be used instead of a switching input,
- whether central switching shall be added,
- whether an 8-bit scene control shall be added,
- whether a status object shall be added for this output channel,
- whether a permanent or time-limited manual override to On shall be possible,
- whether the output shall be turned of permanently by an override,
- whether forced control has to be provided,
- which switching status the output shall take on bus voltage failure and which value the switching object, and where applicable the logic object shall take on bus voltage recovery,
- whether the switching cycles of this output channel shall be counted with or without an upper threshold,
- whether the operating hours for this output channel shall be counted with or without an upper threshold.

Parameter	Settings
<b>Operation mode</b>	<b>Normal mode;</b> Timer mode; Flashing
This parameter determines whether the respective output works as a “normal” maintained switch or as a timer or whether it is flashing. In the further description, the timer mode is referred to as “timer day mode” to have a distinction to the “night mode”, which can be enabled additionally.	

The parameter “Operation mode“ is set to “Timer mode“.

The other parameters are covered in the sections

- Control Value Input
- Central switching
- 8-bit scene control
- Manual override (ON)

## Application program description

February 2019

**KXSK04RC-- Switching Actuator 4-fold**  
**KXSK08RC-- Switching Actuator 8-fold**  
**KXSK0CRC-- Switching Actuator 12-fold**

- Permanent OFF
- Lock
- Central override
- User-defined Control
- Forced control
- Status annunciation
- Counting of switching cycles
- Counting of operating hours

### Parameter „Timer mode“

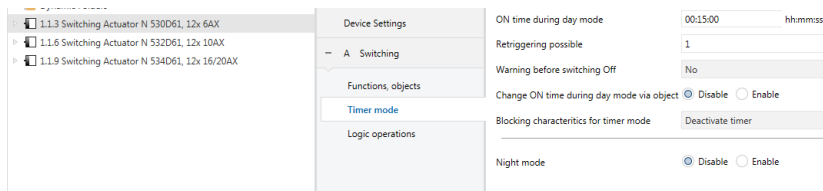

This parameter window is used to set the switching behavior in "Timer mode" of the corresponding actuator output channel.

The parameter window for the output channel is used to set

- how long the timer period shall be,
- whether the timer may be re-triggered,
- whether a warning before switching off shall be executed,
- whether the On period in day mode timer operation shall be changeable at run-time,
- whether night mode with a time- controlled "On" period is desired, and how long the "On" period is,
- whether in night mode a warning before switching off shall be executed.

Parameter	Settings
<b>ON time in day mode</b> [hh:mm:ss]	<b>00:15:00</b> [00:00:00 ... 23:59:59]
This parameter sets the desired on-time for the output in timer day mode.	
<b>Retriggering possible</b>	<b>1</b> [0...5]
This parameter determines whether the On period is restarted and thus the On time is to be extended when a new On telegram is received during an On period. If the parameter is set to "0" then an extension is not possible during the On period. Additionally, it is possible to determine how long the On period can be extended at maximum by receiving several switching telegrams. Thus the maximum settable period is: 1: up to max. 1x ON time 2: up to max. 2x ON time 3: up to max. 3x ON time 4: up to max. 4x ON time 5: up to max. 5x ON time	
<b>Warning before switching Off</b>	<b>No;</b> via briefly switching On – Off; via communication object; via briefly switching On – Off and via communication object;
This parameter determines whether at the end of the On time the output immediately shall be turned off permanently or if a warning shall happen before the output switching off. „No“: The output is immediately switched Off without warning.	

KXSK04RC-- Switching Actuator 4-fold  
 KXSK08RC-- Switching Actuator 8-fold  
 KXSK0CRC-- Switching Actuator 12-fold

Parameter	Settings
<p>With the following parameter settings the output is not immediately switched Off permanently.            If the output is used for lighting control then the user is warned and has ample time to extend the On period of the lighting or if need be turn it on again.            „via briefly switching On – Off“:            The output is switched off for the configurable warning signal period (default setting: 1s) and then switched on again for a configurable time (difference of parameter „warning period“ – parameter „warning signal period“).  <i>Note: The „warning signal period“ shall not be longer than the „warning period“ because otherwise no warning will occur!</i>            If within the warning period the output is switched on again via e.g. the object „switching“ then the timer On period starts again. Otherwise, the output is switched off.            „via communication object“:            Via this selection the communication object „Pre-warning expiration of timer period“ appears, which can be used to send a pre-warning onto the bus e.g. to switch on a warning lamp.            The expiration of the On period of the timer is signaled via the communication object. At the same time the warning period starts with a period defined by the parameter „warning period“. The output is not briefly switched on/off.            If within the warning period the output is switched on again via e.g. the object „switching“ then the timer On period starts again. Otherwise, the output is switched off.            via briefly switching On – Off and via communication object:            Via this selection the communication object „Pre-warning expiration of timer period“ appears, which can be used to send a pre-warning onto the bus e.g. to switch on a warning lamp.            The expiration of the On period of the timer is signaled via the communication object. The output is switched off for the configurable warning signal period (default setting: 1s) and then switched on again for a configurable time (difference of parameter „warning period“ – parameter „warning signal period“).  <i>Note: The „warning signal period“ shall not be longer than the „warning period“ because otherwise no warning will occur!</i>            If within the warning period the output is switched on again via e.g. the object „switching“ then the timer On period starts again. Otherwise, the output is switched off.</p>	
<b>Warning period</b> [hh:mm:ss]	<b>00:00:30</b> [00:00:01...18:12:15]
<p><i>This parameter is only visible if the parameter „Warning before switching Off“ is not set to „No“.</i>            This parameter determines the warning period during which the output stays switched On after the timer expired.  <i>Note: The „warning signal period“ shall not be longer than the „warning period“ because otherwise no warning will occur!</i></p>	
<b>Warning signal period</b> [hh:mm:ss]	<b>00:00:01</b> [00:00:01...18:12:15]
<p><i>This parameter is only visible if the parameter „warning before switching Off“ is set to „via briefly switching On – Off“ or „via briefly switching On – Off and via communication object“.</i>            This parameter determines that, after the On period has expired, the output is not immediately switched off permanently but only switched off for a warning signal period (default setting: 1 second) and then switched on again for a configurable time (difference of parameter „warning period“ – parameter „warning signal period“). After this warning period has expired the output is switched off permanently. If the output is used for lighting control then the user is warned and has ample time to extend the On period of the lighting or, if need be, turn it on again.  <i>Note: The „warning signal period“ shall not be longer than the „warning period“ because otherwise no warning will occur!</i></p>	
<b>Change ON time during day mode via object</b>	<b>Disable;</b> Enable
<p>This parameter determines if the object “Day mode timer” is available.</p>	
<b>Blocking characteristics for time mode</b>	<b>Deactivate timer;</b> Reset timer; Pause timer; no blocking
<p>This parameter determines the blocking behavior in timer operation mode.            „no blocking“:            Blocking of the timer is not possible.            If one of the following parameter settings is selected then a blocking object for the timer appears.</p>	

## Application program description

February 2019

KXSK04RC-- Switching Actuator 4-fold  
KXSK08RC-- Switching Actuator 8-fold  
KXSK0CRC-- Switching Actuator 12-fold

Parameter	Settings
„Pause timer“:	Triggered timer functions are halted and continue running after release of the blocking object at the time when they were halted.
„Reset timer“:	Triggered timer functions are halted. After release of the blocking object the timer is reset and restarted again.
„Deactivate timer“:	Triggered timer functions are stopped. After release of the blocking object the timer is neither continued nor restarted.

The other parameters are covered in the sections

- ☞ Night mode.

**KXSK04RC-- Switching Actuator 4-fold**  
**KXSK08RC-- Switching Actuator 8-fold**  
**KXSK0CRC-- Switching Actuator 12-fold**

**Flashing**

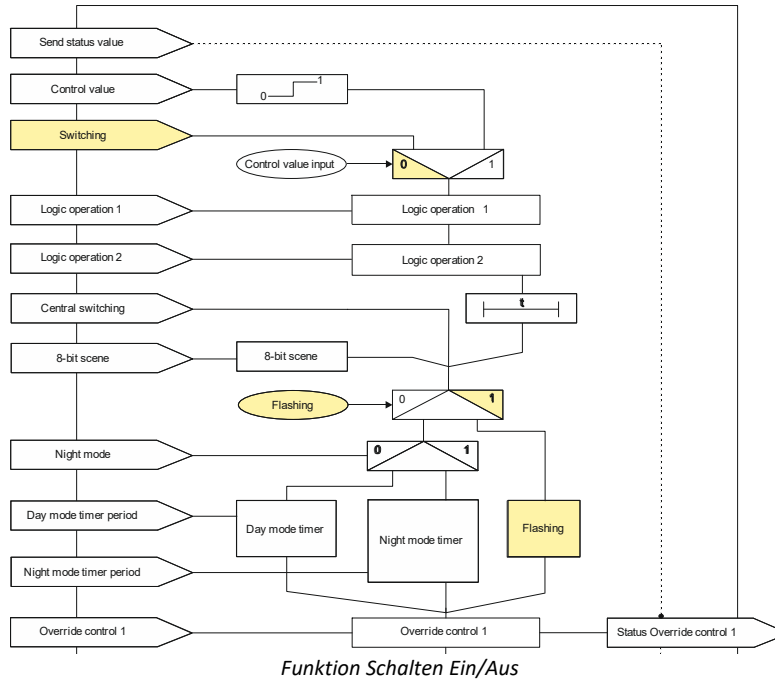

Objects

Obj	Object name	Function	Type	Flag
3	A Switching	ON / OFF	1 Bit	CRT

Via this object switching telegrams are received.

Parameter „Functions, Objects“

## Application program description

February 2019

**KXSK04RC-- Switching Actuator 4-fold**  
**KXSK08RC-- Switching Actuator 8-fold**  
**KXSK0CRC-- Switching Actuator 12-fold**

This parameter window offers selection of the base function (normal mode / timer mode/ flashing) and of further functions of this actuator output channel. This includes,

- whether the output operates as normally open or normally closed contact,
- whether a control value input shall be used instead of a switching input,
- whether central switching shall be added,
- whether an 8-bit scene control shall be added,
- whether a status object shall be added for this output channel,
- whether a permanent or time-limited manual override to On shall be possible,
- whether forced control has to be provided,
- which switching status the output shall take on bus voltage failure and which value the switching object, and where applicable the logic object shall take on bus voltage recovery,
- whether the switching cycles of this output channel shall be counted with or without an upper threshold,
- whether the operating hours for this output channel shall be counted with or without an upper threshold.

Parameter	Settings
<b>Operation mode</b>	<b>Normal mode;</b> Timer mode; Flashing
This parameter determines whether the respective output works as a "normal" maintained switch or as a timer or whether it is flashing. In the further description, the timer mode is referred to as "timer day mode" to have a distinction to the "night mode", which can be enabled additionally.	

The parameter "Operation mode" is set to "Flashing".

The other parameters are covered in the sections

- ☞ Control Value Input
- ☞ Central switching
- ☞ 8-bit scene control
- ☞ Manual override (ON)
- ☞ Permanent OFF
- ☞ Lock
- ☞ Central override
- ☞ User-defined Control
- ☞ Forced control
- ☞ Status annunciation
- ☞ Counting of switching cycles
- ☞ Counting of operating hours

### Parameter „Flashing mode“

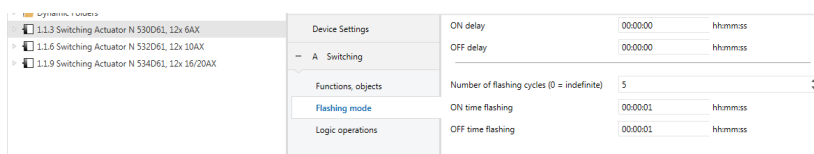

This parameter window is used to set behavior of the corresponding actuator output channel in the operation mode in "Flashing".

The parameter window for the output channel is used to set

- whether an "on" delay shall be executed and how long the period for the on delay is,
- whether an "off" delay shall be executed and how long the period for the off delay is,
- the number of flashing cycles,
- the length of the On period and Off period of a flashing cycle.

KXSK04RC-- Switching Actuator 4-fold  
 KXSK08RC-- Switching Actuator 8-fold  
 KXSK0CRC-- Switching Actuator 12-fold

Parameter	Settings
<b>ON delay</b> [hh:mm:ss]	<b>00:00:00</b> [00:00:00...23:59:59]
This parameter sets the desired on-delay time. The default value 00:00:00 means that ON commands are executed immediately. A set on-delay acts only on the "Switching" object and not on an object for a logic operation allocated to the output as well.	
<b>OFF delay</b> [hh:mm:ss]	<b>00:00:00</b> [00:00:00...23:59:59]
This parameter sets the desired off-delay time. The default value 00:00:00 means that OFF commands are executed immediately. A set off-delay acts only on the "Switching" object and not on a linking object allocated to the output as well.	
<b>Number of flashing cycles</b> (0 = indefinite)	<b>5</b> [0...10000]
<i>This parameter is only visible if the parameter "Operation mode" is set to "Flashing".</i> This parameter determines the desired number of flashing cycles.	
<b>ON time flashing</b> [hh:mm:ss]	<b>00:00:01</b> [00:00:01...00:04:15]
<i>This parameter is only visible if the parameter "Operation mode" is set to "Flashing".</i> This parameter determines the desired On period for a flashing cycle. The flashing frequency can be derived from the parameters for "ON time flashing" and "OFF time flashing".	
<b>OFF time flashing</b> [hh:mm:ss]	<b>00:00:01</b> [00:00:01...00:04:15]
<i>This parameter is only visible if the parameter "Operation mode" is set to "Flashing".</i> This parameter determines the desired Off period for a flashing cycle. The flashing frequency can be derived from the parameters for "ON time flashing" and "OFF time flashing".	

**Application program description**

February 2019

**KXSK04RC-- Switching Actuator 4-fold**  
**KXSK08RC-- Switching Actuator 8-fold**  
**KXSK0CRC-- Switching Actuator 12-fold**

**Logic operation**

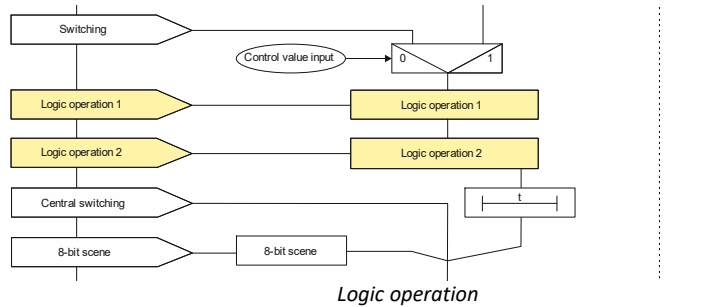

The input value of the switching object or the control value input can be combined with two consecutively linked logic operations. The following logic operations are available: AND, OR, XOR, FILTER and TRIGGER. The respective value of the objects for logic operation can be inverted. Likewise the result of the logic operation for the logic functions AND, OR, XOR, and FILTER can be inverted.

**AND logic operation:**

Only if the values of the logic input and the other input are equal to "1", then the result of the logic operation is "1", otherwise it is "0".

**OR logic operation:**

If at least one of the values of the logic input or the other input is equal to "1", then the result of the logic operation is "1", otherwise it is "0".

**XOR logic operation:**

If the values of the logic input and the other input are equal, then the result of the logic operation is "1", otherwise it is "0".

**FILTER logic operation:**

If the value of the logic input is "1" then the value of the other input is copied to the output of the logic operation. If the value of the logic input is "0", then the value of the other input is not copied, i.e. it is filtered.

If the output of the logic operation shall be inverted and the value of the logic input is "1" then the inverted value of the other input is copied to the output. If the value of the logic input is "0", then the value of the other input is not copied, i.e. it is filtered.

Input value	Value logic input	Output
X	0	---
0	1	0
1	1	1

--- = No output of an output value

X = any value

**TRIGGER logic operation:**

There is no logic input. On any incoming value ("0" or "1") at the other input, the value "1" is set at the output of the logic operation.

Objects

These additional objects appear.

Obj	Object name	Function	Type	Flag
-----	-------------	----------	------	------

KXSK04RC-- Switching Actuator 4-fold  
 KXSK08RC-- Switching Actuator 8-fold  
 KXSK0CRC-- Switching Actuator 12-fold

Obj	Object name	Function	Type	Flag
6	A Logic operation 1	ON / OFF	1 Bit	CRW
Via this object the switching information for the 2nd input of the logic operation 1 to the corresponding output are received. If the parameter setting is "no logic operation", this object is not needed and is therefore not displayed.				
7	A Logic operation 2	ON / OFF	1 Bit	CRW
Via this object the switching information for the 2nd input of the logic operation 2 to the corresponding output are received. If the parameter setting is "no logic operation", this object is not needed and is therefore not displayed.				

## Note:

After a download the logic input has the value it had before the download. After a reset or startup the logic input has the respectively configured value or the value „0“.

## Parameters

Parameter	Settings
<b>Logic operation 1 (2)</b>	<b>no logic operation;</b> AND; OR; XOR; FILTER; TRIGGER
If need be, this parameter adds a logic operation to control switching of the output via an added object "A Logic operation 1" ("A Logic operation 2"). The logic operation object is not subject to a time delay, i.e. the logic operation is always effective immediately. On selection of AND, OR, XOR and FILTER further parameters appear. FILTER logic operation: If the value of the logic input is "1" then the value of the other input is copied to the output of the logic operation. If the value of the logic input is "0", then the value of the other input is not copied, i.e. it is filtered. If the output of the logic operation shall be inverted and the value of the logic input is "1" then the inverted value of the other input is copied to the output. If the value of the logic input is "0", then the value of the other input is not copied, i.e. it is filtered. TRIGGER logic operation: There is no logic input. On any incoming value ("0" or "1") at the other input, the value "1" is set at the output of the logic operation.	
<b>Invert logical input</b>	<b>No;</b> Yes
<i>This parameter is only visible if the parameter "Logic operation 1" respectively "Logic operation 2" is not set to "no logic operation" or "TRIGGER".</i> This parameter determines if the input value of the object "A Logic operation" is inverted.	
<b>Invert logical output</b>	<b>No;</b> Yes
<i>This parameter is only visible if the parameter "Logic operation 1" respectively "Logic operation 2" is not set to "no logic operation" or "TRIGGER".</i> This parameter determines if the output value of the logic operation (AND, OR, XOR, FILTER) is inverted.	
<b>Initial value of logic operation object after bus voltage recovery</b>	Off; On; <b>as before voltage failure</b>
<i>This parameter is only visible if the parameter "Logic operation 1" respectively "Logic operation 2" is not set to "no logic operation" or "TRIGGER".</i> This parameter determines the initial value of logic input object after bus voltage recovery. If the parameter is set to "as before bus voltage failure", then the logic input is set to the value of the logic input object stored at bus voltage failure.	

## Application program description

February 2019

KXSK04RC-- Switching Actuator 4-fold  
 KXSK08RC-- Switching Actuator 8-fold  
 KXSK0CRC-- Switching Actuator 12-fold

### Central switching

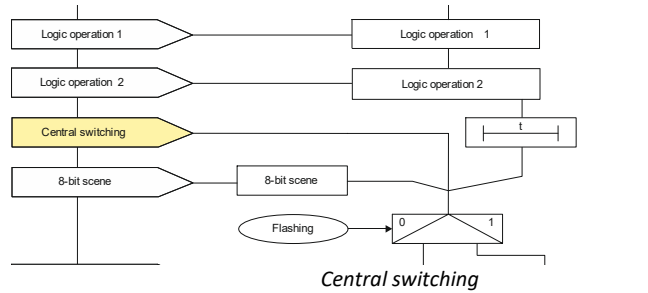

### Objects

These additional objects appear.

Obj	Object name	Function	Type	Flag
8	A Central switching	ON / OFF	1 Bit	CW

Via this object central switching commands are received for this output.

### Parameter „Functions, Objects“

Parameter	Settings
Central switching	Disable; Enalbe

This parameter determines if central switching and the corresponding object is available for this output.

### Parameter „Normal mode“

Parameter	Settings
ON delay (central switching) [hh:mm:ss]	00:00:00 [00:00:00...23:59:59]
<i>This parameter is only visible if the parameter for "central switching" in the parameter window "Functions, objects" is set to "Enable".</i>	
This parameter determines the desired wanted on-delay time for central switching. The default value 00:00:00 means that ON commands are executed immediately. A set on-delay acts only on the "Central switching" object.	
OFF delay (central switching) [hh:mm:ss]	00:00:00 [00:00:00...23:59:59]
<i>This parameter is only visible if the parameter for "central switching" in the parameter window "Functions, objects" is set to "Enable".</i>	
This parameter determines the desired off-delay time for central switching. The default value 00:00:00 means that Off commands are executed immediately. A set on-delay acts only on the "Central switching" object.	

**KXSK04RC-- Switching Actuator 4-fold**  
**KXSK08RC-- Switching Actuator 8-fold**  
**KXSK0CRC-- Switching Actuator 12-fold**

**8-bit scene control**

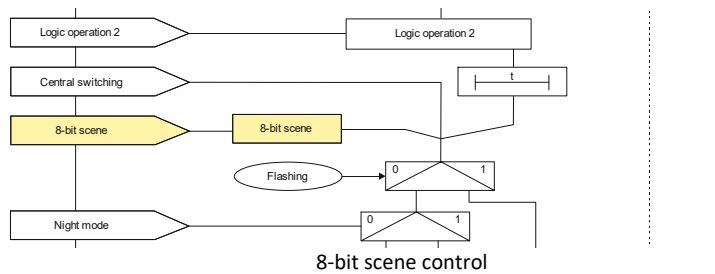

The "8-bit scene recall / store" function enables the user to change the characteristics of a preset scene stored in scene controllers for 8 bit scene control or in actuators with integrated 8 bit scene control, i.e. the user can change brightness levels and switching states of the groups within a scene, without changing the configuration using the ETS.

There is one communication object for transmitting the commands for saving the 8-bit scene and recalling the saved scene using the target scene number.

Before saving a scene the actuators belonging to that scene must be set to the desired light levels and switching states. When receiving a save telegram scene controllers or actuators with 8-bit scene function are commanded to interrogate the current light levels and switching states of the actuators and save these as scene settings.

The scenes refer to the object value of the switching object. When a scene is recalled then the associated value (On / Off) is activated and internally written to the switching object as if an external telegram had been received. The actuator acts as if a switching message had been received via the bus. When a scene is saved the current value of the switching object is saved.

**Note**

If a scene is recalled before the corresponding values have been saved then there is no reaction to that scene recall.

Objects

These additional objects appear.

Obj	Object name	Function	Type	Flag
1	A 8-bit scene	recall / store	1 Byte	CW

This object is used to recall (restore) or program the 8-bit scene with the number x (x = 1...64). Bits 0...5 contain (in binary code) the number of the desired scene as a decimal number between 1 and 64 (in which the decimal number 1 equals the binary number 0, the decimal number 2 equals the binary number 1, etc.). If bit 7 = logical 1, then the scene is programmed and if bit 7 = logical 0, then it is recalled. Bit 6 is currently spare and must be set to logical 0.

Parameter „Functions, Objects“

Parameter	Settings
<b>8-bit scene control</b>	Disable; Enable

This parameter determines if the integrated 8-bit scene control shall be activated for this output. If it is activated, then the corresponding communication object and the parameter window "scene assignments" for the output channel appear for assignment of up to 8 scene numbers per output.

Parameter „Scene assignments“

**Application program description**

February 2019

**KXSK04RC-- Switching Actuator 4-fold**  
**KXSK08RC-- Switching Actuator 8-fold**  
**KXSK0CRC-- Switching Actuator 12-fold**

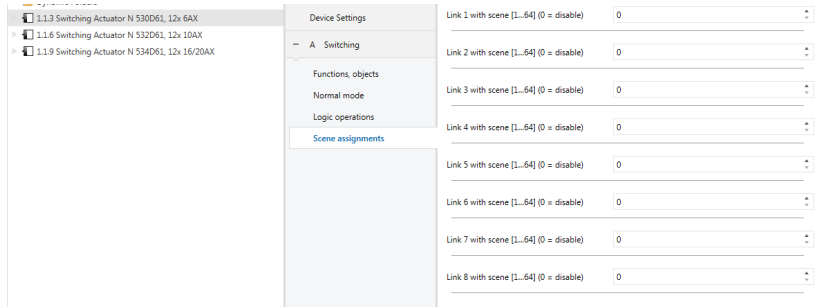

Parameter	Settings
Link 1 with scene [0...64] (0 = disable)	<b>0</b> 1 ... 64
Link 2 with scene [0...64] (0 = disable)	<b>0</b> 1 ... 64
Link 3 with scene [0...64] (0 = disable)	<b>0</b> 1 ... 64
Link 4 with scene [0...64] (0 = disable)	<b>0</b> 1 ... 64
Link 5 with scene [0...64] (0 = disable)	<b>0</b> 1 ... 64
Link 6 with scene [0...64] (0 = disable)	<b>0</b> 1 ... 64
Link 7 with scene [0...64] (0 = disable)	<b>0</b> 1 ... 64
Link 8 with scene [0...64] (0 = disable)	<b>0</b> 1 ... 64
Each of these parameters assigns the output of the actuator to an 8-bit scene with a number in the range of 1 to 64. "0" means that the specific assignment is not used.	
<u>Note:</u> If a scene is recalled before the corresponding values have been saved then there is no reaction to that scene recall.	
<b>8-bit scenes configurable by user</b>	<b>Disable;</b> Enable
<i>This parameter is visible for an active link (i.e. the value for Link is [1...64]).</i> Disable: If "Disable" is selected, then the scenes cannot be set via an 8-bit scene telegram. The values, which are predefined via the parameter „Predefined switching value for scene“ for the relay position on recall of the scene, cannot be changed during operation. Enable: If "Enable" is selected, then the parameter "Delete learned scene" is visible.	
<b>Delete learned scene</b>	<b>Disable;</b> Enable
<i>This parameter is visible for an active link if the parameter "8-bit scenes configurable by user" is set to "Enable".</i> Disable: If "Disable" is selected, then the learned scenes are not deleted when the configuration is loaded into the device. Enable: If "Enable" is selected, then the learned scenes are deleted when the configuration is loaded into the device.	
<b>Predefine scene</b>	<b>Disable;</b>

KXSK04RC-- Switching Actuator 4-fold  
 KXSK08RC-- Switching Actuator 8-fold  
 KXSK0CRC-- Switching Actuator 12-fold

Parameter	Settings
	Enable
<p><i>This parameter is visible for an active link if the parameter "8-bit scenes configurable by user" is set to "Enable" and the parameters "Delete learned scene" is set to "Enable".</i></p> <p>Disable:                      If "Disable" is selected, then the parameter "Predefined switching value for scene" becomes invisible. A scene must be taught in by the user. Already learned scene values are deleted when the configuration is loaded into the device. If no value is learned then the scene is not activated.</p> <p>Enable:                      If "Enable" is selected, then the parameter "Predefined switching value for scene" becomes visible. The value selected as "Predefined switching value for scene" is loaded into the device as scene value when the device configuration is loaded into the device.</p>	
<b>Predefined switching value for scene</b>	<b>Off; On</b>
<p><i>This parameter is visible for an active link if the parameter "8-bit scenes configurable by user" is set to "Disable" or if the parameters "8-bit scenes configurable by user", "Delete learned scene" and "Predefine scene" are set to "Enable".</i></p> <p>This parameter determines the switching value of the scene number preset during configuration and loaded into the device with ETS.</p>	

## Application program description

February 2019

**KXSK04RC-- Switching Actuator 4-fold**  
**KXSK08RC-- Switching Actuator 8-fold**  
**KXSK0CRC-- Switching Actuator 12-fold**

### Night mode

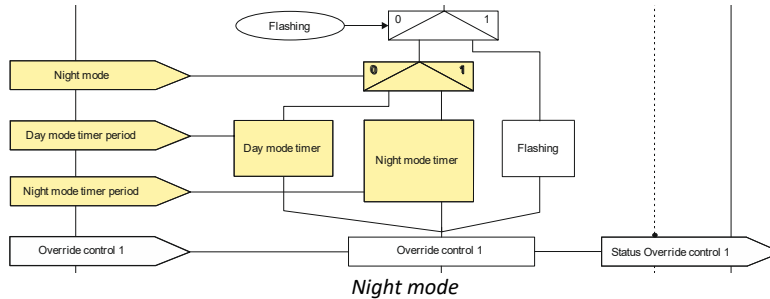

Via an optional object "Night mode" for each output, it can be, if desired, controlled to switch on for a limited time only (e.g. for cleaning crew lighting) instead of permanently switching on. The time limited switching may be configured with warning before turning off with repeated off-on-switching of the output (flashing).

### Objects

These additional objects appear.

Obj	Object name	Function	Type	Flag
10	A Night mode	ON / OFF	1 Bit	CW
This object enables or disables "Night mode" for the corresponding output via the bus. The control signal can be sent by a button, a timer or an automatic building management system, for example. If a logical one is received, then the corresponding output switches to night mode. In "Night mode" the output can no longer be switched on permanently, but only for a limited time (for example, lighting for cleaning for 30 minutes). If the "Warning before switching off" parameter (see corresponding "Normal operation" parameter window) is set to "Yes" then, in night or day timer mode, before the configured ON time has elapsed, you are informed, by the lighting switching off and on again, that e.g. approximately 30 seconds after the first switching off the output will be switched off permanently. This lets you know the end of the ON time and by pressing the light switch again, the lighting will be left ON for a further 30 minutes, for example. If the parameter setting is "Night mode = No", this object is not needed and is therefore not displayed.				
11	A night mode timer	ON time (seconds)	2 Byte (DPT 7.005)	CRW
Via this object the ON time for this output in the „Night mode“ can be changed via the bus. The time is set in seconds. <i>Note:</i> <i>Different from the ETS parameter, because of the DPT, the timer cannot be set to 23:59:59.</i>				
15	A Lock timer	On / Off	1 Bit	CW
Via this object the „Night mode“ for this output can be locked respectively released via the bus. This allows for turning the night mode off when necessary.				

### Parameter

Parameter	Settings
<b>Night mode</b>	Disable; Enable
This parameter determines whether an additional "Night mode" communication object is activated for this output. If night mode is on, the output can no longer be switched on permanently but only for a time-limited period (e.g. for lighting for cleaning). If you set this parameter to "Enable", then the following parameters "On-time during night mode in hh:mm:ss" and "Warn before switching off" are added.	
<b>ON time during night mode</b> [hh:mm:ss]	<b>00:30:00</b> [00:00:00 ... 23:59:59]

KXSK04RC-- Switching Actuator 4-fold  
 KXSK08RC-- Switching Actuator 8-fold  
 KXSK0CRC-- Switching Actuator 12-fold

Parameter	Settings
This parameter determines the ON time during night mode of the output.	
<b>Retriggering possible</b>	<b>1</b> [0...5]
<p>This parameter determines whether the On period is restarted and thus the On time is to be extended when a new On telegram is received during an On period.            If the parameter is set to "0" then an extension is not possible during the On period.            Additionally, it is possible to determine how long the On period can be extended at maximum by receiving several switching telegrams. Thus the maximum settable period is:</p> <p>1: up to max. 1x ON time            2: up to max. 2x ON time            3: up to max. 3x ON time            4: up to max. 4x ON time            5: up to max. 5x ON time</p>	
<b>Warning before switching Off</b>	<b>No;</b> via briefly switching On – Off; via communication object; via briefly switching On – Off and via communication object;
<p>This parameter determines whether at the end of the On time the output immediately shall be turned off permanently or if a warning shall happen before the output switching off.</p> <p>„No“:            The output is immediately switched Off without warning.</p> <p>With the following parameter settings the output is not immediately switched Off permanently.            If the output is used for lighting control then the user is warned and has ample time to extend the On period of the lighting or if need be turn it on again.</p> <p>„via briefly switching On – Off“:            The output is switched off for the configurable warning signal period (default setting: 1s) and then switched on again for a configurable time (difference of parameter „warning period“ – parameter „warning signal period“).  <i>Note: The „warning signal period“ shall not be longer than the „warning period“ because otherwise no warning will occur!</i>            If within the warning period the output is switched on again via e.g. the object „switching“ then the timer On period starts again. Otherwise, the output is switched off.</p> <p>„via communication object“:            Via this selection the communication object „Pre-warning expiration of timer period“ appears, which can be used to send a pre-warning onto the bus e.g. to switch on a warning lamp.            The expiration of the On period of the timer is signaled via the communication object. At the same time the warning period starts with a period defined by the parameter “warning period”. The output is not briefly switched on/off.            If within the warning period the output is switched on again via e.g. the object „switching“ then the timer On period starts again. Otherwise, the output is switched off.</p> <p>via briefly switching On – Off and via communication object:            Via this selection the communication object „Pre-warning expiration of timer period“ appears, which can be used to send a pre-warning onto the bus e.g. to switch on a warning lamp.            The expiration of the On period of the timer is signaled via the communication object. The output is switched off for the configurable warning signal period (default setting: 1s) and then switched on again for a configurable time (difference of parameter „warning period“ – parameter „warning signal period“).  <i>Note: The „warning signal period“ shall not be longer than the „warning period“ because otherwise no warning will occur!</i>            If within the warning period the output is switched on again via e.g. the object „switching“ then the timer On period starts again. Otherwise, the output is switched off.</p>	
<b>Warning period</b> [hh:mm:ss]	<b>00:00:30</b> [00:00:01...18:12:15]
<p><i>This parameter is only visible if the parameter „Warning before switching Off“ is not set to „No“.</i></p> <p>This parameter determines the warning period during which the output stays switched On after the timer expired.</p>	

**Application program description**

February 2019

**KXSK04RC-- Switching Actuator 4-fold**  
**KXSK08RC-- Switching Actuator 8-fold**  
**KXSK0CRC-- Switching Actuator 12-fold**

Parameter	Settings
<b>Warning signal period</b> [hh:mm:ss]	<b>00:00:01</b> [00:00:01...18:12:15]
<p><i>This parameter is only visible if the parameter „warning before switching Off“ is set to „via briefly switching On – Off“ or „via briefly switching On – Off and via communication object“.</i></p> <p>This parameter determines that, after the On period has expired, the output is not immediately switched off permanently but only switched off for a warning signal period (default setting: 1 second) and then switched on again for a configurable time (parameter „warning period“). After this warning period has expired the output is switched off permanently. If the output is used for lighting control then the user is warned and has ample time to extend the On period of the lighting or, if need be, turn it on again.</p>	
<b>Change ON time in night mode via object</b>	<b>Disable;</b> <b>Enable</b>
<p>This parameter determines if the object “Night mode timer” is available.</p>	
<b>Blocking characteristics for time mode</b>	<b>Deactivate timer;</b> <b>Reset timer;</b> <b>Pause timer;</b> <b>no blocking</b>
<p>This parameter determines the blocking behavior in timer operation mode.</p> <p>„no blocking“:                      Blocking of the timer is not possible.</p> <p>If one of the following parameter settings is selected then a blocking object for the timer appears.</p> <p>„Pause timer“:                      Triggered timer functions are halted and continue running after release of the blocking object at the time when they were halted.</p> <p>„Reset timer“:                      Triggered timer functions are halted. After release of the blocking object the timer is reset and restarted again.</p> <p>„Deactivate timer“:                      Triggered timer functions are stopped. After release of the blocking object the timer is neither continued nor restarted.</p>	

**KXSK04RC-- Switching Actuator 4-fold**  
**KXSK08RC-- Switching Actuator 8-fold**  
**KXSK0CRC-- Switching Actuator 12-fold**

**Override**

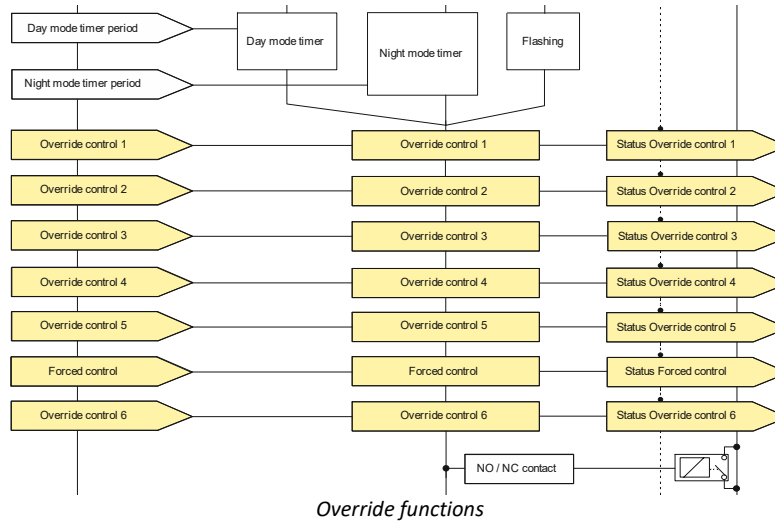

Per output channel up to 6 override functions and a forced control function can be activated. These override functions are available:

- Manual override (ON)
- Permanent OFF
- Lock
- Central override
- User-defined Control

The priority of the override functions is determined by the position in the line of execution. Override 6 has the highest priority, whereas override 1 has the lowest priority.

The forced control function available for each output is situated in the line of execution between overrides 5 and 6 and thus has the second highest priority.

As the objects and parameters for the 6 override functions are the same, only the objects and parameters for override 1 are described below.

Parameter „Functions, Objects“

Parameter	Settings
<b>Override 1</b>	<b>deactivated;</b> Manual override (ON); Permanent OFF; Lock; Central override; User defined

This parameter determines for override function block 1, which override function is activated. When “deactivated” is selected, then the override function block is not present and the parameter window not visible. If one of the other options is selected then the parameter window for that override function block is visible and shows the parameters for the selected override function. The associated objects and parameters for the respective override function are described in the following sections.

**--- Manual override (ON)**

**Application program description**

February 2019

**KXSK04RC-- Switching Actuator 4-fold**  
**KXSK08RC-- Switching Actuator 8-fold**  
**KXSK0CRC-- Switching Actuator 12-fold**

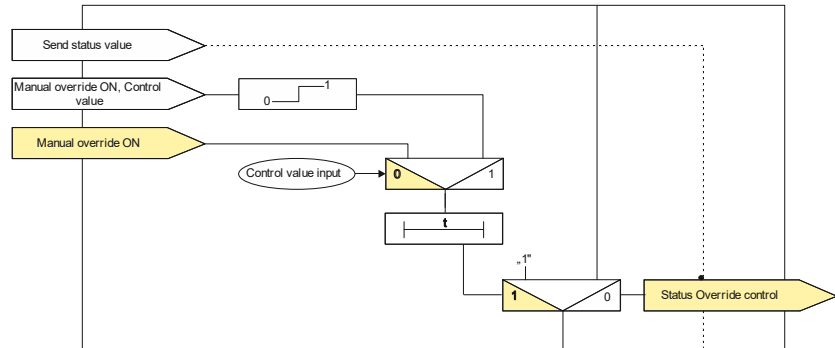

Manual override

Objects

These additional objects appear.

Obj	Object name	Function	Type	Flag
16	A Override 1, Manual ON	ON / OFF	1 Bit	CW
<p><i>This object and further objects are only visible if the parameter „Override 1“ in the parameter window „Functions, objects“ is set to „Manual override (ON)“ and the parameter „Control Value Input“ is set to „Disable“.</i></p> <p>This object enables to switch an output on permanently or for a time-limited period if it has been switched OFF via its "normal" switching input (if need be, in conjunction with a logic operation).</p> <p>Manual (ON) is active if the value of the object is "On".</p> <p>If an inversion of the object value is configured, then Manual (ON) is active when the object value is "Off".</p> <p>The output is only switched off via this object, if the output would be switched off via its "normal" switching input (if need be, with a logic operation). Otherwise, the output remains switched on.</p>				
17	A Override 1, Manual ON, Control value	Value	1 Byte (Percent 0 ... 100%) (DPT5.001) 1 Byte (Count pulses 0 ... 255) (DPT5.010) 2 Byte (Temperature °C) (DPT 9.001) 2 Byte (Illuminance lx) (DPT 9.004) 2 Byte (Current mA) (DPT 9.021) 4 Byte (Power W) (DPT14.056) 2 Byte (Power kW) (DPT 9.024)	CW
<p><i>This object is only visible if the parameter „Control Value Input“ in the parameter window „Override 1“ is set to „Enable“.</i></p> <p>Via this object a control value can be used as input value for the override.</p>				
18	A Override 1, Manual ON, Status	ON / OFF	1 Bit	CRT
<p><i>This object is only visible if the parameter „Status Override“ in the parameter window „Override 1“ is set to „Enable“.</i></p> <p>Via this object the status of the override (active or inactive) can be annunciated.</p>				

Parameter

Parameter	Settings
Control Value Input	Disable; Enable
<p>This parameter determines if a Control Value Input shall be used instead of the switching input for activation or deactivation of the override function.</p> <p>See section "Control Value Input" for further parameters that become visible.</p>	

KXSK04RC-- Switching Actuator 4-fold  
 KXSK08RC-- Switching Actuator 8-fold  
 KXSK0CRC-- Switching Actuator 12-fold

Parameter	Settings
<b>Invert Override Control</b>	<b>No;</b> Yes
This parameter determines whether the input value of the override object is used direct or as inverted value.	
<b>Override Duration</b> [ hh:mm:ss]	<b>00:00:00</b> [00:00:00...18:12:15]
This parameter determines the desired duration for switching the output on via manual override. The override period is restarted with each incoming activation telegram. The override period is indefinite if the parameter value is 00:00:00.	
<b>Status Override</b>	<b>Disable;</b> Enable
This parameter determines if a status object shall become visible. Via this object the status (active / inactive) of the override is annunciated. <i>See section "Status annunciation" for further parameters that become visible.</i>	

*Note: On bus voltage recovery the override function "Manual Override (ON)" is deactivated.*

**Application program description**

February 2019

**KXSK04RC-- Switching Actuator 4-fold**  
**KXSK08RC-- Switching Actuator 8-fold**  
**KXSK0CRC-- Switching Actuator 12-fold**

**--- Permanent OFF**

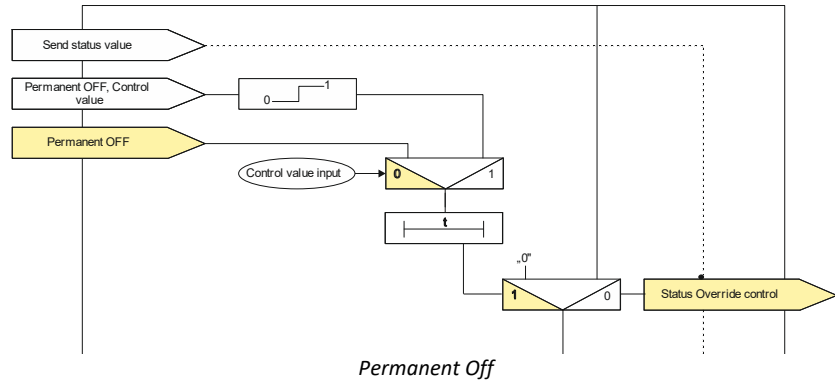

Objects

These additional objects appear.

Obj	Object name	Function	Type	Flag
16	A Override 1, Permanent OFF	ON / OFF	1 Bit	CW
<p><i>This object and further objects are only visible if the parameter „Override 1“ in the parameter window „Functions, objects“ is set to „Permanent OFF“ and the parameter „Control Value Input“ is set to „Disable“.</i></p> <p>This object enables to switch an output off permanently independent of the preceding partial functions. Permanent OFF is active if the value of the object is “On”.</p> <p>If an inversion of the object value is configured, then Permanent OFF is active when the object value is “Off”.</p> <p>The output is only switched on via this object, if the output would be switched on via its "normal" switching input (if need be, with a logic operation). Otherwise, the output remains switched off.</p>				
17	A Override 1, Permanent OFF, Control value	Value	1 Byte (Percent 0 ... 100%) (DPT5.001) 1 Byte (Count pulses 0 ... 255) (DPT5.010) 2 Byte (Temperature °C) (DPT 9.001) 2 Byte (Illuminance lx) (DPT 9.004) 2 Byte (Current mA) (DPT 9.021) 4 Byte (Power W) (DPT14.056) 2 Byte (Power kW) (DPT 9.024)	CW
<p><i>This object is only visible if the parameter „Control Value Input“ in the parameter window „Override 1“ is set to „Enable“.</i></p> <p>Via this object a control value can be used as input value for the override.</p>				
18	A Override 1, Permanent OFF, Status	ON / OFF	1 Bit	CRT
<p><i>This object is only visible if the parameter „Status Override“ in the parameter window „Override 1“ is set to „Enable“.</i></p> <p>Via this object the status of the override (active or inactive) can be annunciated.</p>				

Parameter

Parameter	Settings
Control Value Input	Disable; Enable
This parameter determines if a Control Value Input shall be used instead of the switching input for activation or deactivation of	

KXSK04RC-- Switching Actuator 4-fold  
 KXSK08RC-- Switching Actuator 8-fold  
 KXSK0CRC-- Switching Actuator 12-fold

Parameter	Settings
the override function. See section "Control Value Input" for further parameters that become visible.	
<b>Invert Override Control</b>	<b>No;</b> Yes
This parameter determines whether the input value of the object "Override 1, Permanent OFF" is used direct or as inverted value.	
<b>Status Override</b>	<b>Disable;</b> Enable
This parameter determines if a status object shall become visible. Via this object the status (active / inactive) of the override is annunciated. See section "Status annunciation" for further parameters that become visible.	
<b>Start value / behavior of override input on bus voltage recovery</b>	<b>Off;</b> On; <b>deactivated;</b> Last value
This parameter determines the desired start value / behavior of the input of the function block „Override 1, Permanent OFF“ on bus voltage recovery. If the parameter is set to „deactivated“, then the override function block is deactivated on bus voltage recovery. If the parameter is set to „last value“, then the input of the override function block is set to the value saved on bus voltage failure.	

## Application program description

February 2019

**KXSK04RC-- Switching Actuator 4-fold**  
**KXSK08RC-- Switching Actuator 8-fold**  
**KXSK0CRC-- Switching Actuator 12-fold**

--- Lock

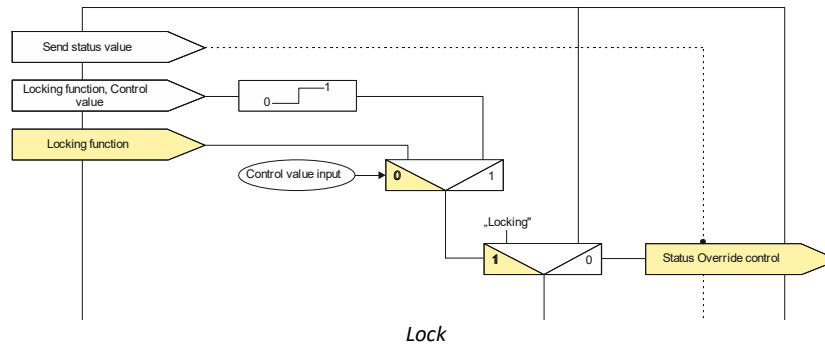

### Objects

These additional objects appear.

Obj	Object name	Function	Type	Flag
16	A Override 1, Lock	ON / OFF	1 Bit	CW
<p><i>This object and further objects are only visible if the parameter „Override 1“ in the parameter window „Functions, objects“ is set to „Lock“ and the parameter „Control Value Input“ is set to „Disable“.</i></p> <p>This object enables to lock an output against changes from preceding partial functions as long as the lock is set. Lock is active if the value of the object is “On”.</p> <p>If an inversion of the object value is configured, then Lock is active when the object value is “Off”.</p> <p>On deactivation of the lock the current value of the processed function chain is transferred from the input of the function block to the output. After the lock has been released the last received value is processed.</p> <p>The lock object effects that all preceding function blocks internally save their values, but these are not processed and sent.</p>				
17	A Override 1, Lock, Control value	Value	1 Byte (Percent 0 ... 100%) (DPT5.001) 1 Byte (Count pulses 0 ... 255) (DPT5.010) 2 Byte (Temperature °C) (DPT 9.001) 2 Byte (Illuminance lx) (DPT 9.004) 2 Byte (Current mA) (DPT 9.021) 4 Byte (Power W) (DPT14.056) 2 Byte (Power kW) (DPT 9.024)	CW
<p><i>This object is only visible if the parameter „Control Value Input“ in the parameter window „Override 1“ is set to „Enable“.</i></p> <p>Via this object a control value can be used as input value for the override.</p>				
18	A Override 1, Lock, Status	ON / AUS	1 Bit	CRT
<p><i>This object is only visible if the parameter „Status Override“ in the parameter window „Override 1“ is set to „Enable“.</i></p> <p>Via this object the status of the override (active or inactive) can be announced.</p>				

### Parameter

Parameter	Settings
Control Value Input	Disable; Enable
This parameter determines if a Control Value Input shall be used instead of the switching input for activation or deactivation of	

KXSK04RC-- Switching Actuator 4-fold  
 KXSK08RC-- Switching Actuator 8-fold  
 KXSK0CRC-- Switching Actuator 12-fold

Parameter	Settings
the override function. <i>See section "Control Value Input" for further parameters that become visible.</i>	
<b>Invert Override Control</b>	<b>No;</b> Yes
This parameter determines whether the input value of the object "Override 1, Lock" is used direct or as inverted value.	
<b>Status Override</b>	<b>Disable;</b> Enable
This parameter determines if a status object shall become visible. Via this object the status (active / inactive) of the override is annunciated. <i>See section "Status annunciation" for further parameters that become visible.</i>	

*Note: On bus voltage recovery the override function "Lock" takes the same state as before bus voltage failure.*

**Application program description**

February 2019

**KXSK04RC-- Switching Actuator 4-fold**  
**KXSK08RC-- Switching Actuator 8-fold**  
**KXSK0CRC-- Switching Actuator 12-fold**

**--- Central override control**

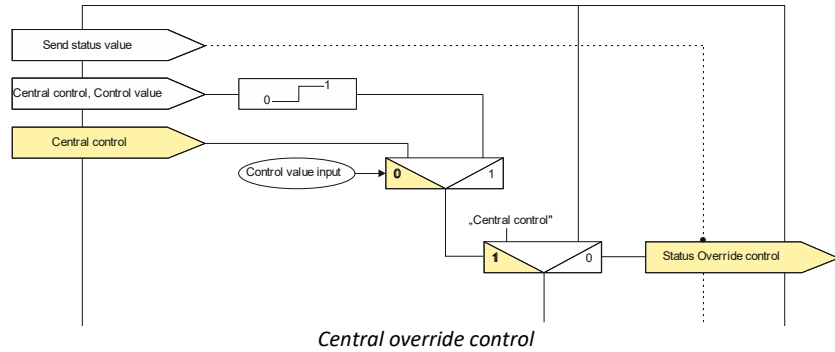

“Central override control” is available for application cases that need a central control e.g. for emergency lighting or in case of fire. This function allows monitoring of the override object on cyclical reception of telegrams. In this case, the override is activated when telegrams are not received within the monitoring period.

Objects

These additional objects appear.

Obj	Object name	Function	Type	Flag
16	A Override 1, Central Control	ON / FF	1 Bit	CW
<p><i>This object and further objects are only visible if the parameter „Override 1“ in the parameter window „Functions, objects“ is set to „Central override“ and the parameter „Control Value Input“ is set to „Disable“.</i></p> <p>This object enables to set the output, independent of preceding control functions, to the current value, to On or Off. The state may be kept permanently until the override is deactivated or for a limited time.</p> <p>Central override is active if the value of the object is “On”.</p> <p>If an inversion of the object value is configured, then Central override is active when the object value is “Off”.</p> <p>On deactivation of the Central override the current value of the processed function chain is transferred from the input of the function block to the output. After the Central override has been released the last received value is processed.</p> <p>The Central override object effects that all preceding function blocks internally save their values, but these are not processed and sent while the override is active.</p>				
17	A Override 1, Central Control, Control	Value	1 Byte (Percent 0 ... 100%) (DPT5.001) 1 Byte (Count pulses 0 ... 255) (DPT5.010) 2 Byte (Temperature °C) (DPT 9.001) 2 Byte (Illuminance lx) (DPT 9.004) 2 Byte (Current mA) (DPT 9.021) 4 Byte (Power W) (DPT14.056) 2 Byte (Power kW) (DPT 9.024)	CW
<p><i>This object is only visible if the parameter „Control Value Input“ in the parameter window „Override 1“ is set to „Enable“.</i></p> <p>Via this object a control value can be used as input value for the override.</p>				
18	A Override 1, Central Control, Status	ON / OFF	1 Bit	CRT
<p><i>This object is only visible if the parameter „Status Override“ in the parameter window „Override 1“ is set to „Enable“.</i></p> <p>Via this object the status of the override (active or inactive) can be annunciated.</p>				

Parameter

Parameter	Settings
-----------	----------

KXSK04RC-- Switching Actuator 4-fold  
 KXSK08RC-- Switching Actuator 8-fold  
 KXSK0CRC-- Switching Actuator 12-fold

Parameter	Settings
<b>Control Value Input</b>	<b>Disable;</b> Enable
This parameter determines if a Control Value Input shall be used instead of the switching input for activation or deactivation of the override function. See section "Control Value Input" for further parameters that become visible.	
<b>Invert Override Control</b>	<b>No;</b> Yes
This parameter determines whether the input value of the object "Override 1, Lock" is used direct or as inverted value.	
<b>Monitoring time</b> [hh:mm:ss]	<b>00:00:00;</b> [00:00:00 ... 18:12:15]
This parameter determines if cyclical reception of telegrams on the object for Central override is monitored and what the duration of the monitoring period is. If the parameter value is 00:00:00 the monitoring is disabled. For all other parameter values the cyclical reception of deactivation telegrams is monitored. The central override is activated when the monitoring time is exceeded. When the next deactivation telegram is received then the central override is deactivated and the output of the override function block stays unchanged.	
<b>Behavior on override activation</b>	Off; On; <b>no change</b>
This parameter determines which value is set as output value of this override function block on activation of the override. „Off“: The value at the output of the function block ist set to „Off“ (0). „On“: The value at the output of the function block ist set to „On“ (1). „no change“: The value at the output of the function block remains unchanged. Values received at the input of the function block are not forwarded to the output.	
<b>Status Override</b>	<b>Disable;</b> Enable
This parameter determines if a status object shall become visible. Via this object the status (active / inactive) of the override is announced. See section "Status annunciation" for further parameters that become visible.	

Note: On bus voltage recovery the override function "Central Override" is deactivated.

## Application program description

February 2019

**KXSK04RC-- Switching Actuator 4-fold**  
**KXSK08RC-- Switching Actuator 8-fold**  
**KXSK0CRC-- Switching Actuator 12-fold**

### --- User-defined override function

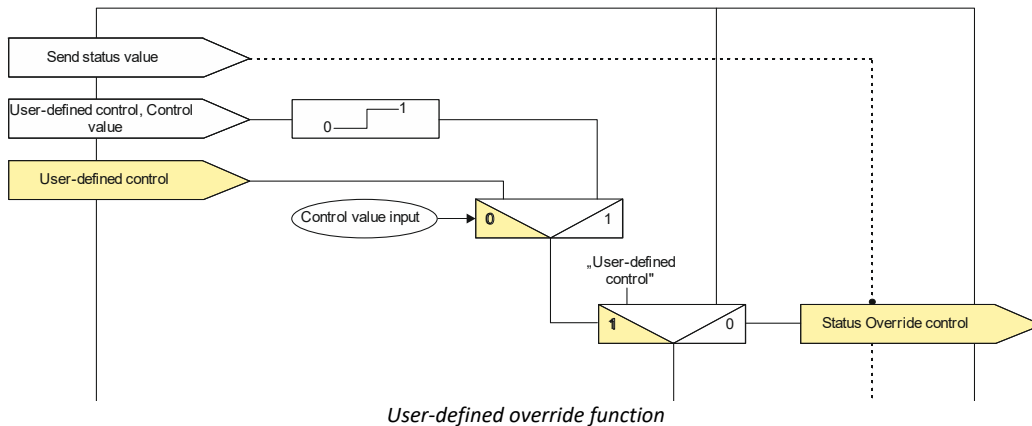

“User-defined override function” is available for application cases, where none of the pre-defined override functions Manual ON, Permanent OFF, Lock, Central override can be applied.

### Objects

These additional objects appear.

Obj	Object name	Function	Type	Flag
16	A Override 1, Used-defined Control	ON / OFF	1 Bit	CW
<p><i>This object and further objects are only visible if the parameter „Override 1“ in the parameter window „Functions, objects“ is set to „User defined“ and the parameter „Control Value Input“ is set to „Disable“.</i></p> <p>This object enables to set the output, independent of preceding control functions, to the current value, to On or Off. The state may be kept permanently until the override is deactivated or for a limited time.</p> <p>User-defined override is active if the value of the object is “On”.</p> <p>If an inversion of the object value is configured, then User-defined override is active when the object value is “Off”.</p> <p>On deactivation of the User-defined override the current value of the processed function chain is transferred from the input of the function block to the output. After the user-defined override has been released the last received value is processed.</p> <p>The user-defined override object effects that all preceding function blocks internally save their values, but these are not processed and sent while the override is active.</p>				
17	A Override 1, Used-defined Control, Control value	Value	1 Byte (Percent 0 ... 100%) (DPT5.001) 1 Byte (Count pulses 0 ... 255) (DPT5.010) 2 Byte (Temperature °C) (DPT 9.001) 2 Byte (Illuminance lx) (DPT 9.004) 2 Byte (Current mA) (DPT 9.021) 4 Byte (Power W) (DPT14.056) 2 Byte (Power kW) (DPT 9.024)	CW
<p><i>This object is only visible if the parameter „Control Value Input“ in the parameter window „Override 1“ is set to „Enable“.</i></p> <p>Via this object a control value can be used as input value for the override.</p>				
18	A Override 1, Used-defined Control, Status	ON / OFF	1 Bit	CRT
<p><i>This object is only visible if the parameter „Status Override“ in the parameter window „Override 1“ is set to „Enable“.</i></p> <p>Via this object the status of the override (active or inactive) can be annunciated.</p>				

**KXSK04RC-- Switching Actuator 4-fold**  
**KXSK08RC-- Switching Actuator 8-fold**  
**KXSK0CRC-- Switching Actuator 12-fold**

Parameter

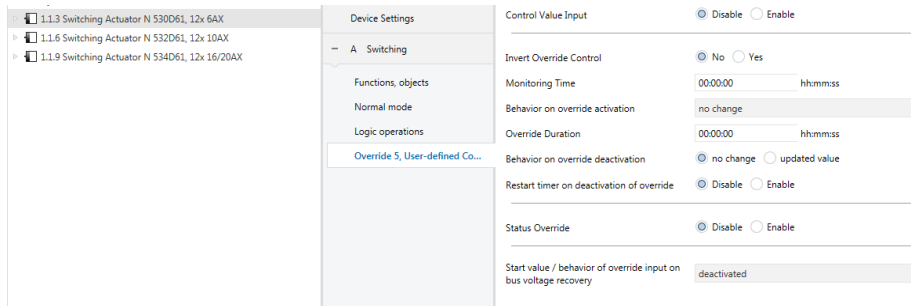

Parameter	Settings
<b>Control Value Input</b>	<b>Disable;</b> <b>Enable</b>
This parameter determines if a Control Value Input shall be used instead of the switching input for activation or deactivation of the override function. <i>See section "Control Value Input" for further parameters that become visible.</i>	
<b>Invert Override Control</b>	<b>No;</b> <b>Yes</b>
This parameter determines whether the input value of the object "Override 1, Lock" is used direct or as inverted value.	
<b>Monitoring time</b> <b>[hh:mm:ss]</b>	<b>00:00:00;</b> <b>[00:00:00 ... 18:12:15]</b>
This parameter determines if cyclical reception of telegrams on the object for user-defined override is monitored and what the duration of the monitoring period is. If the parameter value is 00:00:00 the monitoring is disabled. For all other parameter values the cyclical reception of deactivation telegrams is monitored. The user-defined override is activated when the monitoring time is exceeded. When the next deactivation telegram is received then the user-defined override is deactivated according to the parameter "Behavior on override deactivation".	
<b>Behavior on override activation</b>	<b>Off;</b> <b>On;</b> <b>no change</b>
This parameter determines which value is set as output value of this override function block on activation of the override. „Off“: The value at the output of the function block ist set to „Off“ (0). „On“: The value at the output of the function block ist set to „On“ (1). „no change“: The value at the output of the function block remains unchanged. Values received at the input of the function block are not forwarded to the output.	
<b>Override Duration</b> <b>[ hh:mm:ss]</b>	<b>00:00:00</b> <b>[00:00:00...18:12:15]</b>
This parameter determines the desired duration for switching the output on via manual override. The override period is restarted with each incoming activation telegram. The override period is indefinite if the parameter value is 00:00:00.	

**Application program description**

February 2019

**KXSK04RC-- Switching Actuator 4-fold**  
**KXSK08RC-- Switching Actuator 8-fold**  
**KXSK0CRC-- Switching Actuator 12-fold**

Parameter	Settings
<b>Behavior on override deactivation</b>	updated value; <b>no change</b>
<p>This parameter determines which value is set as output value of this override function block on deactivation of the override.                      „Updated value“: The value at the output of the function block ist updated with the input value to the function override block from the preceeding function block.                      „No change“: The value at the output of the function block remains unchanged. Values received at the input of the function block are not forwarded to the output.</p>	
<b>Restart timer on deactivation of override</b>	<b>Disable;</b> Enable
<p><i>This parameter is only visible if the parameter “Behavior on override deactivation” is set to “no change”.</i>                      This parameter determines if a timer (day mode, night mode or delayed on / off) is restarted on deactivation (Enable) or not (Disable).</p>	
<b>Status Override</b>	<b>Disable;</b> Enable
<p>This parameter determines if a status object shall become visible. Via this object the status (active / inactive) of the override is annunciated.  <i>See section “Status annunciation” for further parameters that become visible.</i></p>	
<b>Start value / behavior of override input on bus voltage recovery</b>	<b>Off;</b> On; <b>deactivated;</b> Last value
<p>This parameter determines the desired start value of input of the function block „Override 1, user-defined control“ on bus voltage recovery.                      If the parameter is set to „deactivated“, then the override function block is deactivated on bus voltage recovery.                      If the parameter is set to „last value“, then the input of the override function block is set to the value saved on bus voltage failure.</p>	

KXSK04RC-- Switching Actuator 4-fold  
 KXSK08RC-- Switching Actuator 8-fold  
 KXSK0CRC-- Switching Actuator 12-fold

--- Forced control

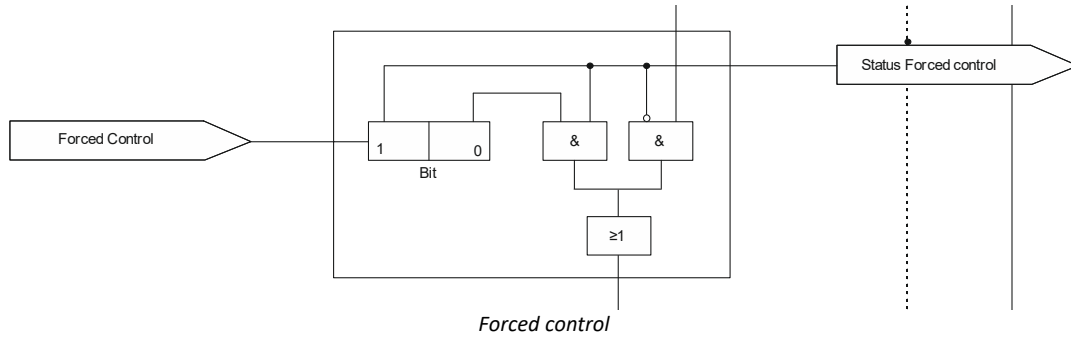

Actuators with forced control allow overriding certain actuator outputs by central control commands. In energy savings mode or at night turning selected luminaires or loads on may be forced to be blocked.

Objects

These additional objects appear.

Obj	Object name	Function	Type	Flag															
13	A Forced control	ON / OFF	2 Bit	CRW															
<p>These 2-bit objects enable a forced switching on or off of the corresponding output, regardless of all other objects impacting on the output, except for override 6..</p> <p>Bit 1 determines whether the forced control is "active" (= 1) or "passive" (0). If bit 1 = 0, then the forced control is "passive" and the switching input is available directly at the forced control output. If bit 1 of the forced control object = 1, then the forced control is "active" and the switching input is disabled. In this case, bit 0 of the forced control object determines the value of the internal forced control output. If forced control is blocked, the switching input is available directly at the internal output of the forced control function.</p> <table border="1" style="width: 100%; border-collapse: collapse; margin-top: 10px;"> <thead> <tr> <th>Bit 1</th> <th>Bit 0</th> <th>Function</th> </tr> </thead> <tbody> <tr> <td>0</td> <td>0</td> <td>Forced control disabled</td> </tr> <tr> <td>0</td> <td>1</td> <td>Forced control disabled</td> </tr> <tr> <td>1</td> <td>0</td> <td>Force controlled OFF</td> </tr> <tr> <td>1</td> <td>1</td> <td>Force controlled ON</td> </tr> </tbody> </table>					Bit 1	Bit 0	Function	0	0	Forced control disabled	0	1	Forced control disabled	1	0	Force controlled OFF	1	1	Force controlled ON
Bit 1	Bit 0	Function																	
0	0	Forced control disabled																	
0	1	Forced control disabled																	
1	0	Force controlled OFF																	
1	1	Force controlled ON																	

Parameter

## Application program description

February 2019

KXSK04RC-- Switching Actuator 4-fold  
KXSK08RC-- Switching Actuator 8-fold  
KXSK0CRC-- Switching Actuator 12-fold

Parameter	Settings															
Forced control	Disable; Enable															
<p>If necessary, you use this parameter to add the 2-bit object "X-n: Forced control", which allows forced switching on or off of the output, regardless of any other objects acting on the output.</p> <p>Bit 1 determines whether the forced control is "active" (= 1) or "passive" (0). If bit 1 = 0, then the forced control is "passive" and the switching input is available directly at the forced control output. If bit 1 of the forced control object = 1, then the forced control is "active" and the switching input is disabled. In this case, bit 0 of the forced control object determines the value of the internal forced control output. If forced control is blocked, the switching input is available directly at the internal output of the forced control function.</p>																
<table border="1"><thead><tr><th>Bit 1</th><th>Bit 0</th><th>Function</th></tr></thead><tbody><tr><td>0</td><td>0</td><td>Forced control disabled</td></tr><tr><td>0</td><td>1</td><td>Forced control disabled</td></tr><tr><td>1</td><td>0</td><td>Force controlled OFF</td></tr><tr><td>1</td><td>1</td><td>Force controlled ON</td></tr></tbody></table>		Bit 1	Bit 0	Function	0	0	Forced control disabled	0	1	Forced control disabled	1	0	Force controlled OFF	1	1	Force controlled ON
Bit 1	Bit 0	Function														
0	0	Forced control disabled														
0	1	Forced control disabled														
1	0	Force controlled OFF														
1	1	Force controlled ON														

KXSK04RC-- Switching Actuator 4-fold  
 KXSK08RC-- Switching Actuator 8-fold  
 KXSK0CRC-- Switching Actuator 12-fold

**Status annunciation**

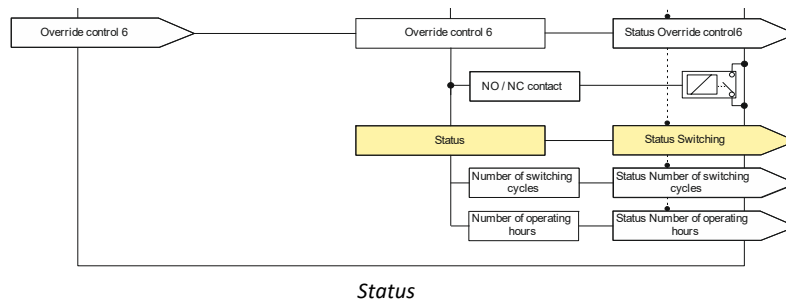

Objects

These additional objects appear.

Obj	Object name	Function	Type	Flag
5	A Status Switching	ON / OFF	1 Bit	CRT

The current switching state of the corresponding output is stored in the status object and this can be queried by a read request or will be sent automatically after each object value change according to the corresponding configuration. If the parameter setting is "Switching status object = no", this object is not needed and is therefore not displayed.

Parameter „Functions, Objects“

Parameter	Settings
Status object	Disable; Enable

This parameter determines whether an "A Status switching" communication object is available for the corresponding output. For example, the status object can be used to display the current output switching status on a display, a panel or a PC with visualization software.

Parameter „Functions, Objects“

Parameter „Switching cycles“

Parameter „Operating hours“

This parameter window allows setting the sending characteristics for status objects.

The settings, via the associated parameters, influence the behavior for the objects "A number of switching cycles", "A operating hours" respectively "A status object" and "A override".

When threshold monitoring is activated then these settings, via the associated parameters, influence the behavior for the objects "A Exceedance of threshold for switching cycles" respectively "A Exceedance of threshold for operating hours".

Parameter	Settings
Send status on request	Disable; Enable

This parameter determines whether the value of the object „A number of switching cycles“ shall be sent when a request is received via object „Send status values“.

**Application program description**

February 2019

KXSK04RC-- Switching Actuator 4-fold  
KXSK08RC-- Switching Actuator 8-fold  
KXSK0CRC-- Switching Actuator 12-fold

Parameter	Settings
Send status on change of status	Disable; Enable
This parameter determines whether the value of the object „A number of switching cycles“ shall automatically be sent on a change of status.	
Send status cyclically [hh:mm:ss]	00:00:00; [00:00:00...18:12:15]
This parameter determines the period for cyclically sending the status value. If the value is 00:00:00 then there is no cyclical sending.	

**KXSK04RC-- Switching Actuator 4-fold**  
**KXSK08RC-- Switching Actuator 8-fold**  
**KXSK0CRC-- Switching Actuator 12-fold**

**Counting of switching cycles**

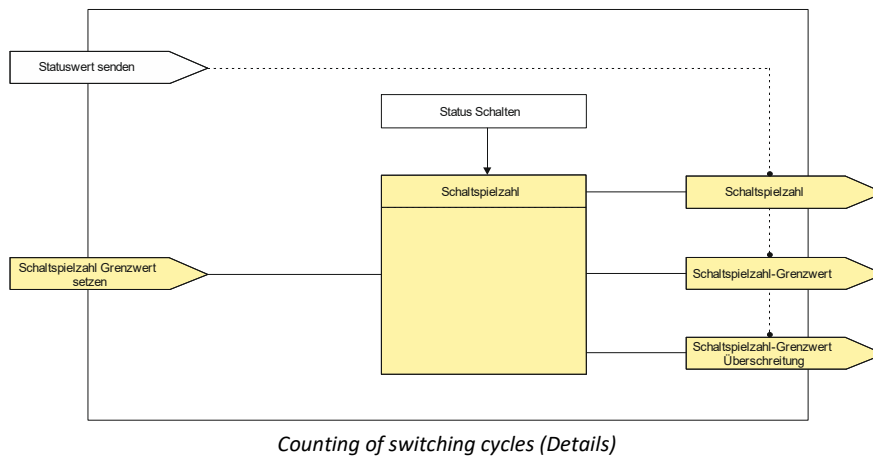
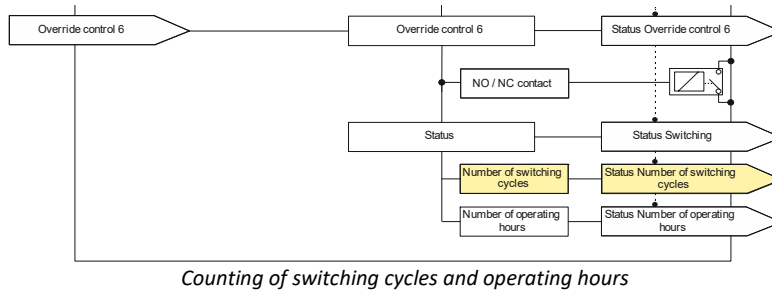

Counting switching cycles enables monitoring of the connected load.

The counter is incremented with each change from “On” to “Off” (in normally open configuration) respectively from “Off” to “On” (in normally closed configuration). In case of warning before switching off, each switching (flashing) is counted. If switching is configured in case of bus power failure and if with this switching the switching cycle threshold is exceeded, then this is transmitted after bus power recovery.

The object “Exceedance of threshold for switching cycles” is only transmitted (once) on change of value. If a new threshold is received or the switching cycle counter is reset then the value of the object “Exceedance of threshold for switching cycles” is only transmitted on change of value of this object.

When the counter object has reached its maximum possible value (4 294 967 295) then its value is retained until it is reset.

The value is reset by writing a value to the object “A number of switching cycles (set value)”.

On bus voltage failure the values of all three objects for switching cycle counting are saved in order to restore them on bus voltage recovery.

The three objects are not reset by a download.

Switching cycle counting is active even if the parameter “Counting of switching cycles” is set to “No”. On activation the current counter value at that time is used in object “A number of switching cycles”.

Objects

These additional objects appear.

Obj	Object name	Function	Type	Flag
34	A Number of switching cycles	Value	4 Byte	CRT

**Application program description**

February 2019

**KXSK04RC-- Switching Actuator 4-fold**  
**KXSK08RC-- Switching Actuator 8-fold**  
**KXSK0CRC-- Switching Actuator 12-fold**

Obj	Obejt name	Funciton	Type	Flag
<p><i>This object is only available if the parameter "Counting of switching cycles" in the "A Functions, Objects" parameter window is set to "Enable".</i></p> <p>Via this object the number of switching cycles for the relevant output (1 switching cycle = switch output on and off again) can be read at any time via the bus.</p> <p>If the parameter "Threshold monitoring" is set to "Enable" then a telegram is sent when the threshold is exceeded.</p>				
34	A Number of switching cycles	Set Value	4 Byte	CW
<p><i>This object is only available if the parameter "Counting of switching cycles" in the "A Functions, Objects" parameter window is set to "Enable".</i></p> <p>Via this object the value for the switching cycle count for the relevant output can be set to an integer value between 1 and 4 294 967 295 via the bus.</p>				
36	A Threshold for switching cycles	Set Value	4 Byte	CRW
<p><i>This object is only available if the parameter "Threshold monitoring" in the "Counting of switching cycles " parameter window is set in each case to "Enable".</i></p> <p>Via this object the threshold for the switching cycle count for the relevant output can be read and set as an integer value between 1 and 4 294 967 295 via the bus.</p>				
37	A Exceedance of threshold for switching cycles	ON / OFF	1 Bit	CRWT
<p><i>This object is only available if the parameter "Threshold monitoring" in the "Counting of switching cycles " parameter window is set in each case to "Enable".</i></p> <p>Via this object the attaining or exceeding of the relevant switching cycle count threshold is reported via the bus respectively it can be queried whether the threshold is being exceeded.</p>				

Parameter „Functions, Objects“

Parameter	Settings
Counting of switching cycles	Disable; Enable
<p>This parameter enables counting of switching cycles (i.e. how often an output has been switched on and off again) for the corresponding output. If the parameter is set to "Enable", then the communication objects "A Number of switching cycles" are added to this output.</p> <p>In addition the parameter window "Counting of switching cycles" appears.</p>	

Parameter „Counting of switching cycles“

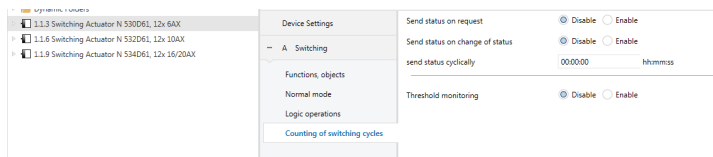

Parameter	Settings
Send status on request	Disable; Enable
<p>This parameter determines whether the value of the object „A number of switching cycles“ shall be sent when a request is received via object „Send status values“.</p>	

KXSK04RC-- Switching Actuator 4-fold  
 KXSK08RC-- Switching Actuator 8-fold  
 KXSK0CRC-- Switching Actuator 12-fold

Parameter	Settings
<b>Send status on change of status</b>	<b>Disable;</b> Enable
This parameter determines whether the value of the object „A Number of switching cycles“ shall automatically be sent on a change of status.	
<b>Value change since last sent</b>	<b>1</b> [0...4 294 967 295]
This parameter determines that the value of the object „A Number of switching cycles“ shall be sent onto the bus if the value of that object has changed by the selected value since the last transmission. <i>Note: The configurable value „0“ is interpreted as „1“.</i>	
<b>Send status cyclically</b> [hh:mm:ss]	<b>00:00:00;</b> [00:00:00...18:12:15]
This parameter determines the period for cyclically sending the status value. If the value is 00:00:00 then there is no cyclical sending.	
<b>Threshold monitoring</b>	<b>Disable;</b> Enable
Via this parameter threshold monitoring is activated when “Enable” is selected. At the same time the associated status parameters and the parameter for input of the threshold for switching cycles appear. <i>See section “Status annunciation”, which describes the status parameters of the function “Status annunciation”.</i> Additionally, these communication objects are added: “A Threshold for switching cycles” for reading and setting the threshold and “A Exceedance of threshold for switching cycles” for annunciating reaching or exceeding the threshold.	
<b>Threshold for switching cycles</b>	<b>1000</b> [0...4 294 967 295]
<i>This parameter is visible when the parameter “Threshold monitoring” is set to “Enable”.</i> This parameter determines the threshold for the output. When the threshold is reached or exceeded then a telegram is sent via the object “A Exceedance of threshold for switching cycles” depending on the sending conditions.	

The parameters visible in the parameter window above the parameter “Threshold monitoring” refer to the object “A Number of switching cycles”.

The parameters visible in the parameter window below the parameter “Threshold monitoring” refer to the object „A Exceedance of threshold for switching cycles“. Configuration of the corresponding status parameters is described in section

➔ Status annunciation

**Application program description**

February 2019

**KXSK04RC-- Switching Actuator 4-fold**  
**KXSK08RC-- Switching Actuator 8-fold**  
**KXSK0CRC-- Switching Actuator 12-fold**

**Counting of operating hours**

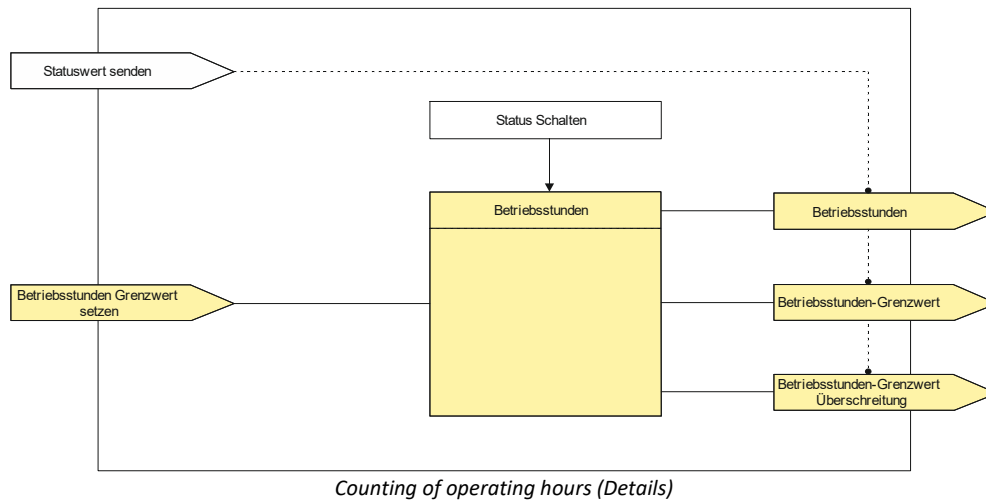
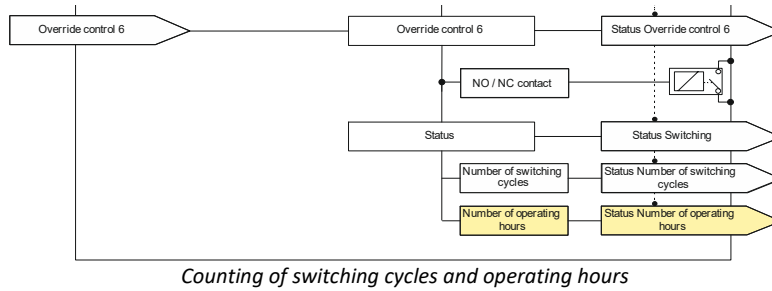

Counting operating hours enables monitoring of the connected load.

The operating hours are counted while the switching status of the channel is "On". Counting is active when the relay configured as normally open is closed respectively when the relay configured as normally closed is open. Only full seconds are counted. The value of the object "Operating hours" is incremented by one when 3,600 seconds have been counted.

The object "Exceedance of threshold for operating hours" is only transmitted (once) on change of value. If a new threshold is received or the operating hours counter is reset then the value of the object "Exceedance of threshold for operating hours" is only transmitted on change of value of this object. When the counter object has reached its maximum possible value (4 294 967 295) then its value is retained until it is reset.

The value is reset by writing a value to the object for the (current) switching cycle value.

Operating hours cannot be counted on bus voltage failure.

On bus voltage failure the values of all three objects for switching cycle counting are saved in order to restore them on bus voltage recovery.

The three objects are not reset by a download.

Counting operating hours is active even if the parameter "Counting of operating hours" is set to "Disable".

Objects

These additional objects appear.

Obj	Object name	Function	Type	Flag
-----	-------------	----------	------	------

KXSK04RC-- Switching Actuator 4-fold  
 KXSK08RC-- Switching Actuator 8-fold  
 KXSK0CRC-- Switching Actuator 12-fold

Obj	Object name	Function	Type	Flag
38	A Operating hours	Value	4 Byte	CRT
<p><i>This object is visible if the parameter "Counting of operating hours" in the "A Functions, Objects" parameter window is set to "Enable" and the in the parameter window "Operating hours" the parameter "Counting of operating hours" is set to "hours".</i></p> <p>Via this object the current number of operating hours for the relevant output (i.e. how many hours the output was ON) can be queried via the bus at any time.</p>				
39	A Operating hours	Value (in seconds)	4 Byte	CRT
<p><i>This object is visible if the parameter "Counting of operating hours" in the "A Functions, Objects" parameter window is set to "Enable" and the in the parameter window "Operating hours" the parameter "Counting of operating hours" is set to "seconds".</i></p> <p>Via this object the current number of operating hours for the relevant output (i.e. how many hours the output was ON) can be queried via the bus at any time.</p>				
40	A Operating hours	Set Value	4 Byte	CRW
<p><i>This object is visible if the parameter "Counting of operating hours" in the "A Functions, Objects" parameter window is set to "Enable".</i></p> <p>Via this object the value for the operating hours count for the relevant output can be set to an integer value between 1 and 4 294 967 295 via the bus. The value is transmitted as hours.</p> <p>This object is always set in hours, independent of the configured setting for the annunciation of the operating hours in seconds or hours via objects 38 or 39.</p>				
41	A Threshold for operating hours	Set Value	4 Byte	CRW
<p><i>This object is only available if the parameter "Counting of operating hours" in the "A Functions, Objects" parameter window is set to "Enable" and the parameter "Threshold monitoring" in the parameter window "Operating hours" is set to "Enable"..</i></p> <p>Via this object the threshold for the operating hours count for the relevant output is sent as an integer value between 1 and 4 294 967 295 to the switching actuator via the bus.</p> <p>The value is transmitted as hours.</p>				
42	A Exceedance of threshold for operating hours	ON / OFF	1 Bit	CRWT
<p><i>This object is only available if the parameter "Counting of operating hours" in the "A Functions, Objects" parameter window is set to "Enable" and the parameter "Threshold monitoring" in the parameter window "Operating hours" is set to "Enable"..</i></p> <p>Via this object the attaining or exceeding of the relevant operating hours threshold is reported via the bus respectively it can be queried whether the threshold is being exceeded.</p>				

#### Parameter „Functions, Objects“

Parameter	Settings
Counting of operating hours	Disable; Enable
<p>This parameter enables counting of operating hours (i.e. for how many hours the output was switched on) for the corresponding output. If the parameter is set to "Enable", then only the communication objects "A Operating hours" are added to this output. Additionally, the parameter window for operating hours appears.</p>	

## Application program description

February 2019

**KXSK04RC-- Switching Actuator 4-fold**  
**KXSK08RC-- Switching Actuator 8-fold**  
**KXSK0CRC-- Switching Actuator 12-fold**

### Parameter „Operating hours“

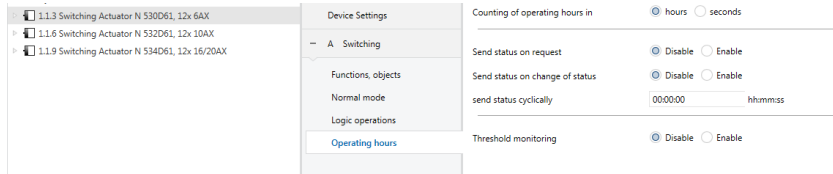

Parameter	Settings
<b>Counting of operating hours in</b>	hours; seconds
This parameter determines if the operating hours are counted for the output in hours or seconds.	
<b>Send status on request</b>	Disable; Enable
This parameter determines whether the value of the object „A Operating hours“ shall be sent when a request is received via object „Send status values“.	
<b>Send status on change of status</b>	Disable; Enable
This parameter determines whether the value of the object „A Operating hours“ shall automatically be sent on a change of status.	
<b>Value change since last sent</b>	1 [0...4 294 967 295]
This parameter determines that the value of the object „A Operating hours“ shall be sent onto the bus if the value of that object has changed by the selected value since the last transmission.	
<b>Send status cyclically</b> [hh:mm:ss]	00:00:00; [00:00:00...18:12:15]
This parameter determines the period for cyclically sending the status value. If the value is 00:00:00 then there is no cyclical sending.	
<b>Threshold monitoring</b>	Disable; Enable
Via this parameter threshold monitoring is activated when “Enable” is selected. At the same time the associated status parameters and the parameter for input of the threshold for operating hours appear. <i>See section “Status annunciation”, which describes the status parameters of the function “Status annunciation”.</i> Additionally, these communication objects are added: “A Threshold for operating hours” for reading and setting the threshold and “A Exceedance of threshold for operating hours” for annunciating reaching or exceeding the threshold.	
<b>Threshold for operating hours</b>	1000 [0...4 294 967 295]
<i>This parameter is visible when the parameter “Threshold monitoring” is set to “Enable”.</i> This parameter determines the threshold for the output. When the threshold is reached or exceeded then a telegram is sent via the object “A Exceedance of threshold for operating hours” depending on the sending conditions.	

The parameters visible in the parameter window above the parameter “Threshold monitoring” refer to the object “A Operating hours”.

The parameters visible in the parameter window below the parameter “Threshold monitoring” refer to the object „A Exceedance of threshold for operating hours“. Configuration of the corresponding status parameters is described in section

➔ Status annunciation

KXSK04RC-- Switching Actuator 4-fold  
KXSK08RC-- Switching Actuator 8-fold  
KXSK0CRC-- Switching Actuator 12-fold

**Space for notes**