

dakanimo

Manual for KNX-switch „kamereon“
Version 1.2



Contents

1. Safety and Warranty	5
1.1. Work on electric connections	5
1.2. Manufacturer warranty	5
2. KNX - basic information	6
2.1. Why bus-technology? Why KNX?	6
2.2. Communication of KNX-devices	6
3. Operating philosophy for KNX-installations	7
3.1. Simple operation with complex results	7
3.2. Uniformity	7
3.3. Icons	8
4. Technical data / device structure	9
4.1. Touch surfaces of the switch	10
5. Putting kamereon into service	13
5.1. Loading of product data	13
5.2. Assigning a physical address	13
5.3. Transferring the application programme	14
5.4. Alternative programming	14
6. Range of features of the kamereon switch	15
6.1. General functions	16
6.1.1. Basic brightness of the LEDs upon operation (%)	16
6.1.2. Mode of the LEDs after restarting the device or download via ETS	16
6.1.3. Duration of the “cleaning”-feature after activation (min.)	16
6.1.4. Period between key operation/telegramme and activation of standby-mode (min.)	16
6.1.5. Brightness on standby-mode (%)	17
6.1.6. Wake-up from standby by proximity sensor	17
6.1.7. Feedback upon key operation by click-sound/vibration signal	17
6.2. Master operation	18
6.2.1. Function	18
6.2.2. Activate priority function by longer key touch	19
6.2.3. Time until detection of a longer key touch (ms)	19
6.3. LEDs on master operation	19
6.3.1. Day-mode basic colour of LEDs	19
6.3.2. Day-mode colour at key touch	20
6.3.3. Day-mode colour at ON-telegramme	20
6.3.4. Day-mode colour at OFF-telegramme	20
6.3.5. Shut-off delay of LED after activation via key touch	21
6.3.6. Same colours and shut-off delays of LEDs in day- and in night-mode?	21
6.3.7. Activation of day-mode via key touch	22
6.3.8. Activation of night-mode via key touch	22
6.3.9. LEDs brightness in day-mode (%)	23
6.3.10. LEDs brightness in night-mode (%)	23
6.3.11. Specification of colours/shut-off delays/brightness by objects	23

6.4.	Key 1 (upper left corner)	23
6.4.1.	Function	24
6.4.2.	Activate priority function by longer key touch	25
6.4.3.	Time until detection of a longer key touch (ms)	25
6.4.4.	Secondary function of the wheel	25
6.5.	Key 1 secondary function wheel - only with selection „Secondary function ...“	25
6.5.1.	Type of output telegramme	25
6.5.2.	Linear 0...100% / lower limit (%)	26
6.5.3.	Linear 0...100% / upper limit (%)	26
6.5.4.	Linear 1 byte, 0...255 / lower limit	26
6.5.5.	Linear 1 byte, 0...255 / upper limit	26
6.5.6.	Linear 2 byte, 0...65535 / lower limit	27
6.5.7.	Linear 2 byte, 0...65535 / upper limit	27
6.5.8.	Linear 2-byte-float / lower limit basis (-20000...20000)	27
6.5.9.	Multiplier	27
6.5.10.	Linear 2-byte-float / upper limit basis (-20000...20000)	28
6.5.11.	Multiplier	28
6.5.12.	Minimum telegramme interval upon manually change of values on the wheel (ms)	28
6.5.13.	Linear 4-byte-float	28
6.5.14.	Colour of active segments	28
6.6.	LED 1 (upper left corner)	29
6.6.1.	Day-mode basic colour of the LEDs	29
6.6.2.	Day-mode colour at key touch	29
6.6.3.	Day-mode colour at ON-telegramme	29
6.6.4.	Day-mode colour at OFF-telegramme	30
6.6.5.	Shut-off delay of LED after activation via key touch	30
6.6.6.	Same colours and shut-off delays of LEDs in day- and in night-mode?	31
6.6.7.	Activation of day-mode via key touch	31
6.6.8.	Activation of night-mode via key touch	32
6.6.9.	LEDs brightness in day-mode (%)	32
6.6.10.	LEDs brightness in night-mode (%)	32
6.6.11.	Colour of the LED when locked	33
6.6.12.	Specification of colours/shut-off delays/brightness by objects	33
6.7.	Key 2 (upper right corner)	33
6.8.	LED 2 (upper right corner)	33
6.9.	Key 3 (lower left corner)	33
6.10.	LED 3 (lower left corner)	33
6.11.	Key 4 (lower right corner)	33
6.12.	LED 4 (lower right corner)	33
6.13.	Key 5 (center)	33
6.14.	Main function of the wheel	34
6.14.1.	Type of output telegramme	34
6.14.2.	Linear 0...100% / lower limit (%)	34

6.14.3.	Linear 0...100% / upper limit (%)	34
6.14.4.	Linear 1 byte, 0...255 / lower limit	35
6.14.5.	Linear 1 byte, 0...255 / upper limit	35
6.14.6.	Linear 2 byte, 0...65535 / lower limit	35
6.14.7.	Linear 2 byte, 0...65535 / upper limit	35
6.14.8.	Linear 2-byte-float / lower limit base (-20000...20000)	35
6.14.9.	Multiplier	36
6.14.10.	Linear 2-byte-float / upper limit base (-20000...20000)	36
6.14.11.	Multiplier	36
6.14.12.	Minimum telegramme interval upon manually change of values on the wheel (ms)	36
6.14.13.	Linear 4-byte-float	37
6.14.14.	4-segment-operation	37
6.14.15.	Colour of segment 1 upon activation of segment operation	37
6.14.16.	Colour of segment 2 upon activation of segment operation	38
6.14.17.	Colour of segment 3 upon activation of segment operation	38
6.14.18.	Colour of segment 4 upon activation of segment operation	38
6.14.19.	Colour of segment 1 upon operation	38
6.14.20.	Colour of segment 2 upon operation	38
6.14.21.	Colour of segment 3 upon operation	39
6.14.22.	Colour of segment 4 upon operation	39
6.14.23.	Minimum telegramme interval upon manually change of values on the wheel (ms)	39
6.15.	LEDs wheel	39
6.16.	Segment 1 - only active upon 4-segment-operation	39
6.17.	Segment 2 - only active upon 4-segment-operation	40
6.18.	Segment 3 - only active upon 4-segment-operation	40
6.19.	Segment 4 - only active upon 4-segment-operation	40
6.20.	Temperature	40
6.20.1	Telegramme interval temperature	40
6.20.2.	Offset temperature (°C * 0.1)	40
6.20.3.	Transmission of "temperature" from a difference of (°C * 0,1, 0=Deactivated)	41
6.20.4.	Internal temperatur basis (0...100)	41
6.20.5.	Multiplier	41
6.20.6.	Processing of the external temperature	41
6.20.7.	External temperature basis (0...100)	42
6.20.8.	Multiplier	42
6.20.9.	Performance when locking the temperature	42
6.21.	PI. controller	42
6.21.1.	Nominal value/set point (°C)	42
6.21.2.	Control parameters	43
6.21.3.	Proportional range (°C * 0.1)	43
6.21.4.	Reset time (min.)	43

1. Safety and Warranty

All dakanimo products have been designed, produced and dispatched with the greatest possible care. Please consider the following advice for a trouble-free installation and for a fast service if required.

1.1. Work on electric connections

Work on electricity grids of either 230 V or 110 V are only to be executed by adequately trained and qualified professionals who can provide the according certificates or qualification documents and may only be done according to the relevant customary rules and standards for electric installation. We recommend the same for any work on bus-voltage-regulated devices. Before mounting or demounting of the particular product please make sure to clear the voltage/bus voltage. Please consider the relevant country specific regulations, the valid KNX guidelines as well as the regulations for SELV (Safety Extra Low Voltage).

All dakanimo products are designed for appropriate use only (as described in the operating instructions). Changes or modifications of any kind (including coatings) are not permitted and will result in a loss of all warranties and guarantees. After unpacking the product(s), please check immediately for any visible damage (in particular breakage of glass). In case of damage the devices must under no circumstances be put into operation. If for this or any other reason an operation without risk may supposedly not be guaranteed, the device must be put out of operation immediately and be secured against accidental operation and/or accidental installation.

1.2. Manufacturer's warranty

dakanimo products are tested in accordance with applicable regulations and manufactured with the utmost care. The guarantor, dakanimo GmbH, D-22359 Hamburg, resp. the dakanimo distributor in the relevant country, grants a guarantee period of 3 years from date of manufacture. For a full list of all dakanimo distributors see www.dakanimo.com. This guarantee covers manufacturing and material defects of dakanimo devices.

This warranty is independent from the existing laws. The guarantee does not cover natural wear and tear, environmental changes/disturbances or transportation damage. Furthermore it does not cover damages caused by non-observance of the operation and maintenance instructions and/or improper installation (i.e. not by professionals). Any batteries or bulbs supplied with the device are not covered by the warranty.

In order to keep this limited warranty in effect, after detection of the defect, the original and unmodified device has to be adequately packed, sufficiently franked and sent together with the invoice, sales receipt and a short written error description to the guarantor respectively the local distributor..

If the guarantee claim proves legitimate the guarantor will at its own discretion repair or replace the device within a reasonable timeframe. Further claims are not covered by the guarantee. In particular, the guarantor is not liable for consequential damages resulting from possibly existing defects of the device. Should the guarantee claim not be justified (for example after the expiry of the warranty period or defects not covered by the warranty), the guarantor can try a cost-effective repair of the device against charge.

2. KNX – basic information

KNX is an open standard for applications in the building system technology. More than 300 companies worldwide support this standard as manufacturers.¹ Thanks to this certification by the KNX Association the devices of these manufacturers can be interlinked without limitation. More than 40.000 installation companies in more than 125 countries take advantage of this global standard.²

One of these 300 manufacturers is dakanimo. Founded in 2014 dakanimo GmbH develops high-end design objects in the area of KNX technology for smart homes.

2.1. Why bus technology? Why KNX?

In classic electrical installation the control functions are firmly connected to the energy distribution. Therefore subsequent adjustments and changes are very elaborate and difficult. Also room-superordinate control functions such as for example central functions can only be implemented with considerable effort.

KNX separates the level „function“ from the level „energy distribution“. The SELV control cable is laid parallel to the power cable (230 V). This control cable enables the data exchange between the devices and can partially provide energy for bus-devices. The amount of cabling work is lower compared to the classic electric installation. Control, regulation and the like – i.e. all functions – of the individual bus users/devices are determined by programming. Programming requires ETS (Engineering Tool Software).

KNX is a bus technology with distributed intelligence. This means that a central control unit is not necessary. The programming is in each individual device. The functions of a certain KNX device have to be determined with the communications objects and the adjustable parameters that can be selected in ETS.

2.2. Communication of the KNX devices

For a ready-to-use and functional system only the power supply and the programming of the KNX devices via ETS are necessary. ETS serves as the tool for planning, project engineering and also the start-up of KNX devices.

In order to communicate between ETS and the devices as well as for communication of the devices among themselves „telegrammes“ are sent by bus. A telegramme consists of bus-specific information and content information. A telegramme is sent with 9.600 bits per second. A KNX switching telegramme (including receipt) uses the bus therefore for 20 milliseconds.

For a rapid and loss-free communication via bus it is important to build up a KNX system (with areas and lines) as well as a programming with as little telegrammes as possible. The operating philosophy of KNX systems is ideal for this.

¹ as for 04/2014

² See www.knx.org. as for 04/2014.

3. Operating philosophy for KNX installations

Apart from a professional electrical installation and a careful programming we consider the operating philosophy as the deciding factor for the successful implementation of KNX systems and a guarantee for the kamereon experience .

3.1. Simple operation with complex results

kamereon was created to meet the requirements of different operating philosophies. The possibilities of KNX systems are numerous and can be simply operated by the master function of the kamereon switch. In this mode the entire switch responds as one touch-sensitive area.

kamereon is frequently used as a scene pushbutton in master operation. This applies both to the entrance situation (residents entering the house/the flat or residents leaving the house/the flat) and to the particular rooms. Thus:

- scene 1 „Entering“
- scene 2 „Leaving“

In combination with the detection of a short or a long touch of kamereon the possibilities expand. Also a change from master operation to individual operation is possible. This being:

- short touch - scene 1 „Entering“
- short touch - scene 2 „Leaving“
- long touch - change to individual operation
- Frequent use: lower right key, long touch - change back to master operation (this function is possible with any object)

3.2 Uniformity

Human behavioural research shows that frequent repetitions of similar movement sequences or operation steps are quickly internalised and become part of a routine. Such learned operation leads towards a higher acceptance of intelligent building systems and to a rewarding experience for the user.

The most frequently used key arrangement is

- Upper left key scene 1 „Entering“
- Upper right key scene 2 „Leaving“
- Lower left key scene 3 „light and shade day-mode“
- Lower right key scene 4 „light and shade night-mode“

Key no. 5 in the center and the wheel remain deactivated. This key arrangement is usually implemented in all the rooms, including the switches near the entrance.

Regardless of whether kamereon is programmed with above mentioned basic functions or in a more sophisticated manner, it is recommended to use a uniform order of operations and functions on all switches inside an object/system.

3.3 Icons

In addition to the recommendation of assigning the same functions to the touch areas, an optional laser engraving can help operating the switches even more. However, the principle of uniformity still applies. Below you find a selection of the icons provided by dakanimo and also, as an example, the top 5 laser engravings used with kamereon.

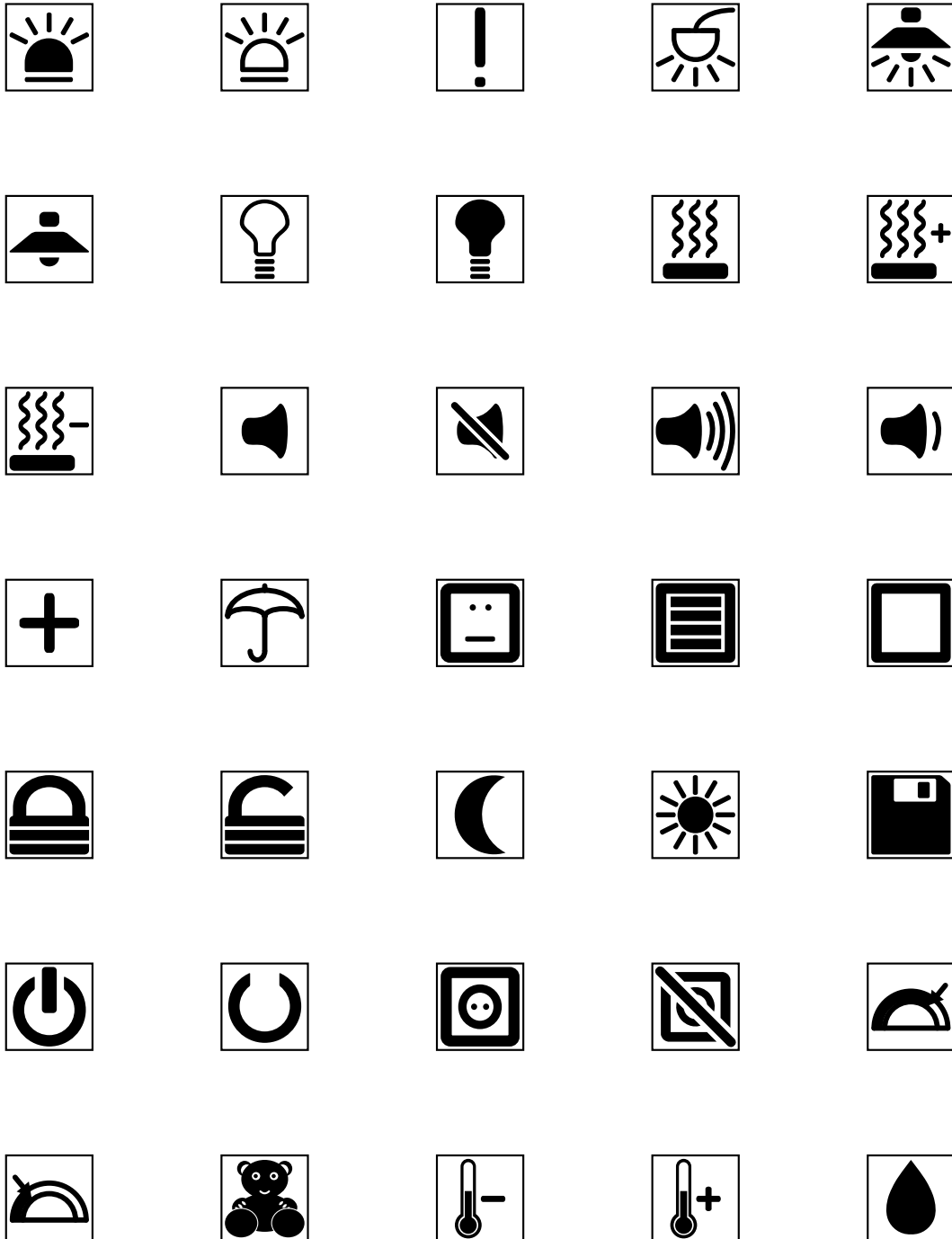

4. Technical data / device structure

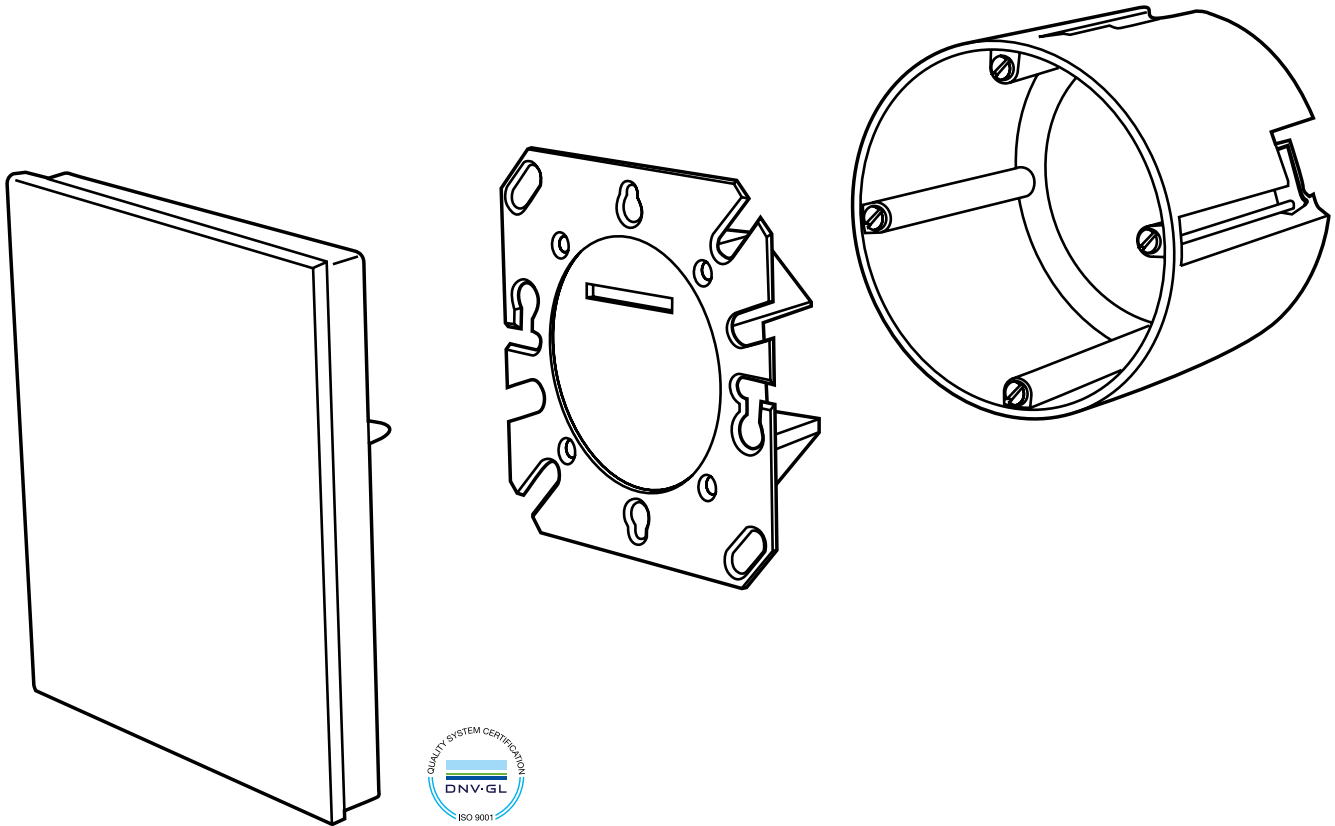

Please use (european) installation boxes with flat head screws only. Screws with bigger heads (round head screws) might unstable the connection between switch and powerbox.

4.1. Touch surfaces of the switch

Numbers 1-5 indicating the touch areas/buttons of the switch.

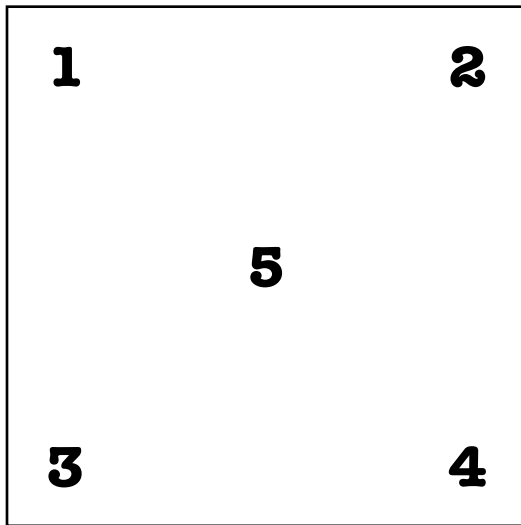

Exemplary descriptions of the switch with icons:

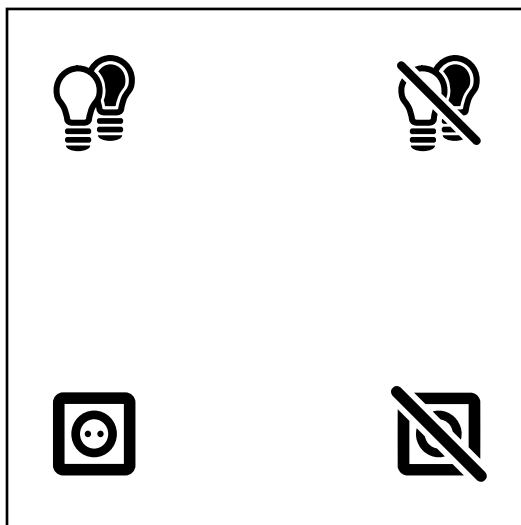

Key 1: light-scene on

Key 2: light-scene off

Key 3: power outlet/socket on

Key 4: power outlet/socket off

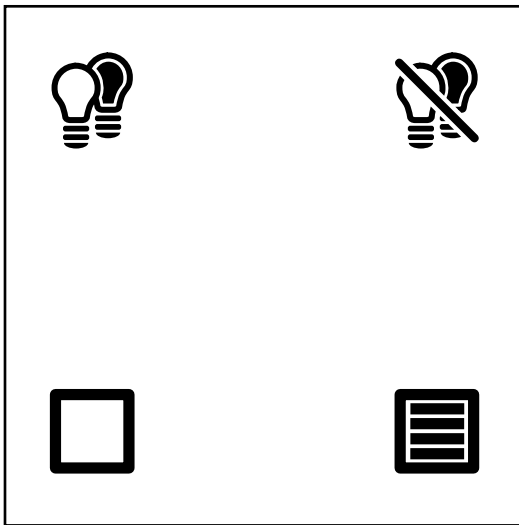

Key 1: scene on
 Key 2: scene off
 Key 3: blinds up
 Key 4: blinds down

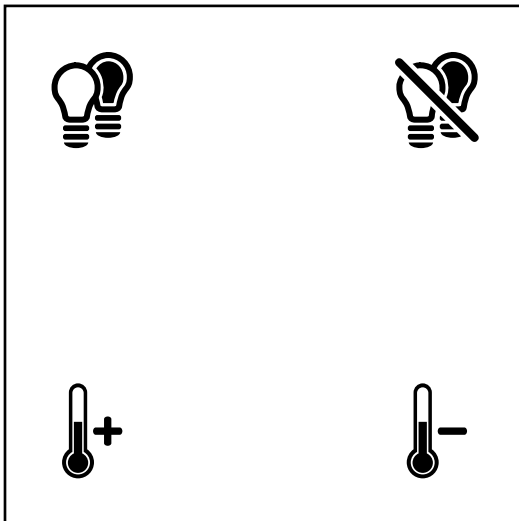

Key 1: scene on
 Key 2: scene off
 Key 3: temperature plus
 Key 4: temperature minus

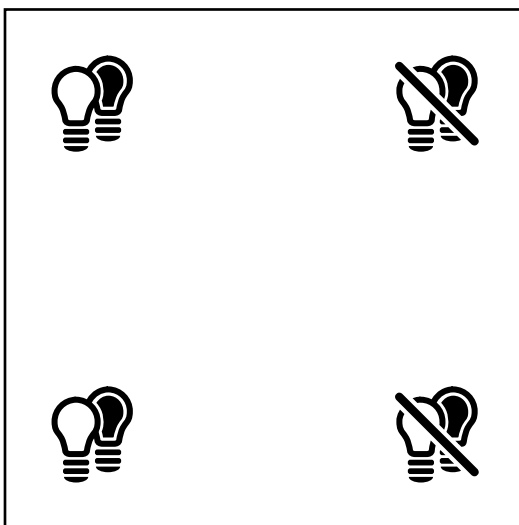

Key 1: scene on
 Key 2: scene off
 Key 3: scene on
 Key 4: scene off

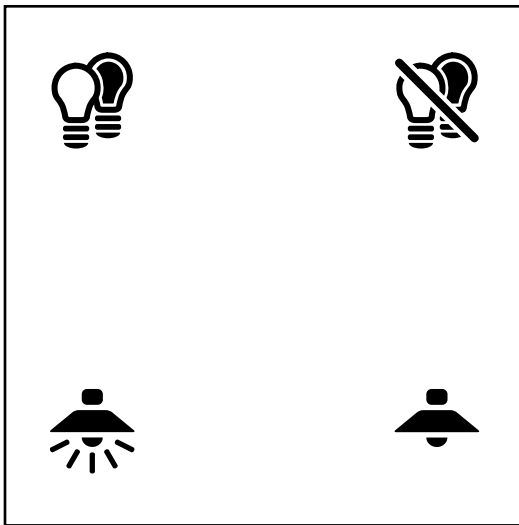

- Key 1: scene on
- Key 2: scene off
- Key 3: ceiling light on
- Key 4: ceiling light off

5. Putting kamereon into service

Apart from the power supply the programming via ETS is necessary for operationg kamereon..

ETS IS USED TO

- assign individual and system/object adapted addresses to the particular kamereon switches. By these physical addresses the individual bus members within the system are distinctively recognizable and selectable.
- provide the particular bus members with the application programme. The application programme includes the parameter settings for the desired functions resp. the desired behaviour of the system.

For programming of a kamereon switch please follow the steps below:

1. Load product data into ETS.
2. Assign a physical address.
3. Transfer application programme together with specified parameter to kamereon.

5.1. Load product data

Import product data into ETS. For latest product data please see www.dakanimo.com. Product data need ETS version 4 or higher.

5.2. Assign a physical address

In order to assign the physical address to the respective kamereon switch please follow the steps below.

1. Connect the device to the bus via terminal KNX.
2. Connect the device via terminal 24 V to a separate 24 V power supply. Usually the second wire pair of the bus cable can be used.
3. Apply the corresponding voltage to both terminals.
4. Transfer the physical address via ETS (for example putting into service/programming/physical address). During this programming process ETS will request to push the „programming button“.³
5. Push the „programming button“. The „programming button“ is triggered by a key combination as follows:
 - a. Press all outer keys (in the corners) at the same time for approx. 1 second.
 - b. The switch is now set to „Locked“-mode indicated by a constant blue light. At the same time the wheel shows a permanent flashing.
6. After pushing the „programming button“ in the center of the switch (key no. 5) the LEDs will flash up once in blue and all LEDs (including the wheel) remain permanently blue. The device is now in programming mode.
7. Please observe the programming process on ETS.

³ for details see ETS 4. as per 04/2014.

5.3. Transferring the application programme

kamereon switches, like all other KNX devices, are only fully operational when, beside the physical address, also the application has been loaded:

1. Choose the corresponding devices in ETS for programming.
2. Via putting into service / programming / application programme start the upload of the programme and the parameter setting⁴
3. During the application upload process you will see a blue flash of the wheel for approx. 30 seconds. Finally all of kamereon's LEDs will flash approx. 7 times in red and green.
4. To verify if the application upload was successful choose „Adr Prg Par Grp Cfg“ in ETS.
 - a. Adr = individual address is set
 - b. Prg = application programme has been loaded
 - c. Par = parameter settings have been loaded
 - d. Grp = group addresses have been loaded
 - e. Cfg = media type settings have been loaded
 - f. Requirements Adr, Prg, Par and Cfg must be fulfilled.⁵

After assigning the physical address and transferring the application programme the commissioning of a kamereon switch is concluded. For the desired interaction within the system/the object it is necessary to allocate appropriate group addresses. By assigning these group addresses the kamereon switch can then be connected with other bus members of the KNX system.

5.4. Alternative programming

The physical address and the application can also be programmed in a single process. Please choose in ETS set-up/programming/physical address&application.⁶

⁴ also see ETS 4. as per 04/2014.

⁵ also see ETS 4. as per 04/2014.

⁶ also see ETS 4. as per 04/2014.

6. Range of features of the kamereon switch

kamereon is a KNX switch to create special room experiences. kamereon was designed for indoor applications and is distinguished by its intuitive operation :

- The 12 RGB-LEDs of the wheel as well as the RGB-LEDs of the corner touch areas enable a wide range of eye-catching visual design.
- The 4 corner touch areas of the switch together with the wheel in the center of the switch are illuminated according to their status and/or object-dependent.
- A fifth touch area is located in the center of the switch.
- The buzzer provides a status- and/or object-dependent acoustic feedback by sounding a click.
- By vibrating the switch provides a status- and/or object-dependent sensoric feedback.

In general a simple and quick programming of kamereon is possible via the the parameter dialogue. For a more sophisticated setting various possibilities exceeding the parameter dialogue are possible via numerous objects.

6.1. **General functions**

The basic settings for the functioning/the operation of the kamereon switch are stored in the parameter dialogue.

6.1.1. **Basic brightness of the LEDs upon operation (%)**

PROPERTIES:

1. Freely adjustable between 0 and 100.

DESCRIPTION:

The brightness of the LEDs can not only be set individually in the keys' and the wheel's various submenus but also quick and easy via objects.

COMMONLY USED AND RECOMMENDED SETTING:

80.

6.1.2 **Mode of the LEDs after restarting the device or download via ETS**

PROPERTIES:

Day mode or night mode.

DESCRIPTION:

Behaviour of kamereon's LED-lighting after restart and/or programming via ETS.

COMMONLY USED AND RECOMMENDED SETTING:

Day mode.

6.1.3. **Duration of the "cleaning"-feature after activation (min.)**

PROPERTIES:

1. Freely adjustable between 1 and 60 (minutes).

DESCRIPTION:

Determines the length of time for locking the entire switch after activating the „cleaning“ function. It can be activated in two ways:

1. Via the object no. 150.
2. Press all outer keys (in the corners) at the same time for approx. 1 second.

COMMONLY USED AND RECOMMENDED SETTING:

For example on a specially marked switch via objects with a shut-off delay of 20 minutes.

6.1.4. **Period between key operation/telegramme and activation of standby-mode (min.)**

PROPERTIES:

1. Freely adjustable between 1 and 240 (minutes).

PROPERTIES:

Determines the period of time for the optional change of LEDs' luminous intensity after the last activity. Whereby activity may be, for example, the direct operation of kamereon or the communication via objects.

COMMONLY USED AND RECOMMENDED SETTING:

120 minutes.

6.1.5. **Brightness on standby-mode (%)**

PROPERTIES:

1. Freely adjustable 0 and 100.

DESCRIPTION:

The brightness of the LEDs can not only be set individually in the keys' and the wheel's various submenus and via objects but also quickly and easily by using this function in stand-by. This function is therefore directly related to „Period between key operation/telegramme and activation of stand-by mode (min.)“

COMMONLY USED AND RECOMMENDED SETTING:

25.

6.1.6. **Wake-up from standby by proximity sensor**

PROPERTIES:

Yes / No.

DESCRIPTION:

The built-in proximity sensor can be used both for activating the light (out of stand-by mode) and for the output of an object.

COMMONLY USED AND RECOMMENDED SETTING:

Object-dependant. Frequently used in sleeping areas: yes.

6.1.7. **Feedback upon key operation by click-sound/vibration signal**

PROPERTIES:

Deactivated, vibration, click, click/vibration.

DESCRIPTION:

Apart from the optical display via RGB-LEDs kamereon offers further extensive sensoric possibilities of giving feedback. A short vibration signal for approx. 0.5 seconds upon key touch. A click is a smartphone-characteristic sound. Click/vibration is the combination of both sensoric feedbacks. .

COMMONLY USED AND RECOMMENDED SETTING:

Click/vibration.

Important note:

Both click and vibration signals draw temporarily high currents. These currents are partially buffered inside kamereon, so that the time of the buffers recharge is low if the switch is operated unusually quick and often.

6.2. **Master operation**

The basic settings for the single-switch-operation of kamereon are stored in the parameter dialogue „master operation“ .

6.2.1. **Function**

PROPERTIES:

Switch Single button operation, dim Single button operation, blinds Single button operation and freely assignable .

freely assignable is sub-divided into:

Deactivated

ON-telegramme

OFF-telegramme

ON-telegramme with priority

OFF-telegramme with priority

dim relativly

1 x value (0...100%)

1 x value (1 byte, 0...255)

1 x value (2 byte, 0...65535)

1 x value (2 byte-float)

1 x value (4 byte-float)

1 x scene

1 x RGB (3 byte, red-green-blue)

1 x time (3 byte, hour-minute-second)

1 x date (3 byte, day-month-year)

2 x value (0...100%)

2 x value (1 byte, 0...255)

2 x value (2 byte, 0...65535)

2 x value (2 byte-float)

2 x value (4 byte-float)

2 x scene

2 x RGB (3 byte, red-green-blue)

2 x time (3 byte, hour-minute-second)

2 x date (3 byte, day-month-year)

DESCRIPTION:

Listing and setting of all possible „commands“ of a touch area. In master operation mode all touch areas respond as one single touch area. kamereon’s possibilities are doubled by differentiating between short and long key touches.

COMMONLY USED AND RECOMMENDED SETTING:

2 x scene. Scenes „coming“ and „leaving“ are frequently used.

Important note:

By combining short and long touches in master operation mode it is possible to install a two-level-operation: first level for operators not educated in detail with the system. With the longer key touch the second level is activated in order to reach the various set functions of kamereon. The parameter dialogue of kamereon is extended accordingly with „function key touch short“ and „function key touch long“.

6.2.2. Activate priority function by longer key touch

PROPERTIES:

Yes / No.

DESCRIPTION:

Sends a priority command upon „Yes“ via bus.

COMMONLY USED AND RECOMMENDED SETTING:

No.

6.2.3 Time until detection of a longer key touch (ms)

PROPERTIES:

500 to 10.000 ms.

DESCRIPTION:

Debounce time to differentiate between long and short key touch of kamereon.

COMMONLY USED AND RECOMMENDED SETTING:

2.000 ms.

6.3. LEDs on master operation

The basic settings for the illumination of the single-switch-operation of kamereon are stored in the parameter dialogue „LEDs master operation“.

6.3.1. Day mode basic colour of LEDs

PROPERTIES:

Off, Cyan, Magenta, Blue, Yellow, Green, Red and White.

DESCRIPTION:

Colour of all LEDs upon selection of master operation.

COMMONLY USED AND RECOMMENDED SETTING:

Blue.

Important note:

Depending on kamereon's background colours have a different impact. For example in a piano black kamereon the colour magenta does not appear as brilliant as in a snow mountain white kamereon switch. Individual backgrounds also have an influence on the appearance of the LED colours. Therefore it is possible to mix colours via 3 byte RGB object exactly according to customers' requirements and then transfer it to the kamereon.

For example: The RGB-value for white in a snow mountain white kamereon is 255 255 255. Due to the white surface this colour setting appears a little bit too reddish. The RGB value 190 255 255 in this case appears to be a brighter white to the human eye.

6.3.2. Day-mode colour at key touch

PROPERTIES:

Off, Cyan, Magenta, Blue, Yellow, Green, Red and White.

DESCRIPTION:

Colour of all LEDs upon random key touch.

COMMONLY USED AND RECOMMENDED SETTING:

Off.

6.3.3. Day-mode colour at ON-telegramme

PROPERTIES:

Off, Cyan, Magenta, Blue, Yellow, Green, Red and White.

DESCRIPTION:

Colour of all LEDs according to object value „On“.

COMMONLY USED AND RECOMMENDED SETTING:

Off.

6.3.4. Day-mode colour at OFF-telegramme

PROPERTIES:

Off, Cyan, Magenta, Blue, Yellow, Green, Red and White.

DESCRIPTION:

Colour of all LEDs according to object value „Off“.

COMMONLY USED AND RECOMMENDED SETTING:

Off.

6.3.5. **Shut-off delay of LED after activation via key touch**

PROPERTIES:

Basic colour after releasing the key, 1 to 10 seconds, 1, 2, 5, 10, 15 and 30 minutes, 1 hour, change upon operation/telegramme.

DESCRIPTION:

Determines the shut-off delay (persistence time) of the respective LEDs. The shut-off delay is also influenced by the time itself as well as by other activities like „Releasing the key“, other telegrammes, and so on, as required.

APPLICATION:

kamereon offers a very extensive colour scheme for the LED areas, corresponding to the operation philosophy. For example:

- Lighting object

kamereon is installed as a lighting object and its operation is to be intuitively via the LED areas. The upper left key is backlit in green for scene 1 „Entering“, the upper right key is backlit in blue for scene 2 „Day mode“, the lower left key is backlit in red for scene 3 „Night mode“ and the lower right key is backlit in yellow for scene 4 „Leaving“. The colour upon touching the key is magenta. In addition „Basic colour after releasing the key“ is set respectively for each key. The user receives a positive feedback via vibration/click as well as optical by seeing the colour magenta. Upon releasing the touch areas, kamereon illuminates them again according to the preset light object..

- Trained status objects

Another operating philosophy follows the trained colour schemes of „On“ = „green“ and „Off/Stand-by“ = „red“. When using this concept the basic colour remains off and the user, by seeing the colours red and green, recognizes immediately the status of the system resp. of the device.

COMMONLY USED AND RECOMMENDED SETTING:

Change upon operation/telegramme.

Important note:

Colours can not only help the user to operate complex systems but they can also be very inspiring. However, a full exhaustion of all of kamereon’s possibilities does not necessarily lead to a helpful support for the user. In other words: if the options basic colour, colour upon key touch, colour at on-telegramme and colour at off-telegramme are set and active, the user does probably not easily understand his own intelligent home system. .

6.3.6. **Same colours and shut-off delays of LEDs in day- and in night-mode?**

PROPERTIES:

Yes / No.

DESCRIPTION:

Via an object it is possible to have kamereon change the entire colour scheme including shut-off delays of the colours between two programmes. This can be done either in a private environment, for example deactivating all colours in night-mode. In other objects a more reddish colour scheme was used for outdoor temperatures above 30 °C and a blueish colour scheme for lower temperatures. Other examples for different colour schemes are

wellness and spa areas, supportive arrangements for the human biorhythm etc.

When switching value „0“ activates the day mode and value „1“ activates the night mode.

COMMONLY USED AND RECOMMENDED SETTING:

Object-dependant. No clear recommendation.

6.3.7. **Activation of day-mode via key touch**

PROPERTIES:

No local activation, activation upon key touch, activation after shut-off delay.

DESCRIPTION:

kamereon's day- / night-modes represent two different colour schemes. The change between these two modes can be done via objects of the KNX bus or locally by operating the switch.

DESCRIPTION:

It is possible in several ways to obtain different levels of brightness and/or different colour schemes if desired while operating the kamereon switch. For example different levels of brightness between operation and stand-by: After 60 minutes kamereon is to dim the LEDs to 5% brightness, increase the brightness to 60% upon operation and then leave it at 30% for 5 more minutes. In the general tab the stand-by is therefore set to 60 minutes and brightness to 5%, the „shut-off delay of LED after activation via key touch“ is set to 5 minutes, „activation of day-mode via key touch“ is set on „activation upon key touch“, „activation night-mode via key touch“ is set to „activation with shut-off delay“, „LEDs brightness in day-mode (%)“ is set to 60% and „LEDs brightness in night-mode (%)“ is set to 30%.

For this switching between day- / night-mode the setting for „Same colours and shut-off delays in day- and night-mode“ has to be set to „no“.

COMMONLY USED AND RECOMMENDED SETTING:

No local activation. Switching is generally done via objects, for example via a brightness-controlled object of a visualization.

6.3.8. **Activation of night mode via key touch**

PROPERTIES:

No local activation, activation upon key touch, activation after shut-off delay.

DESCRIPTION:

kamereon's day/night modes represent two different colour schemes. The change between these two modes can be done via objects of the KNX bus or locally by operating the switch.

DESCRIPTION:

It is possible in several ways to obtain different levels of brightness and/or different colour schemes if desired while operating the kamereon switch. For example different levels of brightness between operation and stand-by.

Please see also the example above „Activation of day-mode via key touch“.

COMMONLY USED AND RECOMMENDED SETTING:

No local activation. Switching is generally done via objects, for example via a brightness-controlled object of a visualization.

6.3.9. **LEDs brightness in day mode (%)**

PROPERTIES:

0 to 100%.

DESCRIPTION:

Light intensity of all LEDs

COMMONLY USED AND RECOMMENDED SETTING:

60% with piano black and 40% with snow mountain white.

6.3.10 **LEDs brightness in night mode (%)**

PROPERTIES:

0 to 100%.

DESCRIPTION:

Light intensity of all LEDs

COMMONLY USED AND RECOMMENDED SETTING:

15% with piano black and 5% with snow mountain white.

6.3.11 **Specification of colours/shut-off delays/brightness by objects**

PROPERTIES:

Yes / No.

DESCRIPTION:

Apart from the quick and easy setting of kamereon via the parameter dialogue it is generally possible to determine or change all properties via objects, for example further possibilities such as mixing RGB-colours.

COMMONLY USED AND RECOMMENDED SETTING:

No clear rule. In systems with visualizations the option „Yes“ is frequently used .

6.4. **Key 1 (upper left corner)**

kamereon has five buttons - rather touch-areas - and a wheel. Description of the upper left touch area no.1 as follows. This description is the same for all outer buttons.

6.4.1. **Function**

PROPERTIES:

Switch single-button-operation, dim single-button-operation, blinds single-button-operation and freely assignable .

freely assignable is sub-divided into:

Deactivated

ON-telegramme

OFF-telegramme

ON-telegramme with priority

OFF-telegramme with priority

Dim relatively

1 x value (0...100%)

1 x value (1 byte, 0...255)

1 x value (2 byte, 0...65535)

1 x value (2 byte-float)

1 x value (4 byte-float)

1 x scene

1 x RGB (3 byte, red-green-blue)

1 x time (3 byte, hour-minute-second)

1 x date (3 byte, day-month-year)

2 x value (0...100%)

2 x value (1 byte, 0...255)

2 x value (2 byte, 0...65535)

2 x value (2 byte-float)

2 x value (4 byte-float)

2 x scene

2 x RGB (3 byte, red-green-blue)

2 x time (3 byte, hour-minute-second)

2 x date (3 byte, day-month-year)

DESCRIPTION:

Listing and setting of all possible „commands“ of a touch area. kamereon's possibilities are doubled by differentiating between short and long key touches.

COMMONLY USED AND RECOMMENDED SETTING:

2 x scene. Scenes „Entering“ and „Leaving“ are frequently used.

Important note:

By combining short and long touches in master operation mode it is possible to install a two-level-operation: first level for operators not educated in detail with the system. With the longer key touch the second level is activated in order to reach the various set functions of kamereon.

6.4.2. **Activate priority function by longer key touch**

PROPERTIES:

Yes / No.

DESCRIPTION:

Sends a priority command upon „Yes“ via bus.

COMMONLY USED AND RECOMMENDED SETTING:

No.

6.4.3 **Time until detection of a longer key touch (ms)**

PROPERTIES:

500 to 10.000 ms.

DESCRIPTION:

Debounce time to differentiate between long and short key touch of kamereon.

COMMONLY USED AND RECOMMENDED SETTING:

2.000 ms.

6.4.4. **Secondary function of the wheel**

PROPERTIES:

Not used, via short key touch, via long key touch.

DESCRIPTION:

kamereon's operation philosophy adapts to the specific user (not the other way round). The user, together with the architect, the technical planners and systems integrators, determines how the respective rooms will be „brought to life“. One of the possibilities is choosing a certain „channel“ via the touch area and then select the desired value with the wheel.

COMMONLY USED AND RECOMMENDED SETTING:

Not used.

6.5. **Key 1 secondary function wheel - only with selection „Secondary function of the wheel“**

The touch area „Key 1“ is used as „channel selection“. The desired function (for example dimming, loudness, or else) is then set by secondary function wheel.

6.5.1. **Type of output telegramme**

PROPERTIES:

Linear 0...100%, linear 1 byte, 0...255, linear 2 byte, 0...65536, linear 2-byte-float, linear 4-byte-float.

DESCRIPTION:

According to the clockwise touch operation the respective output values will be given. The values of the wheel

are increased clockwise. Values can either be jumped to or approached. In the setting „Linear 0...100%“ „jumping to“ 3:00 o'clock corresponds to „approaching to“ 25% !

COMMONLY USED AND RECOMMENDED SETTING:

Linear 0...100%.

6.5.2. **Linear 0...100% / lower limit (%)**

PROPERTIES:

0 to 100%.

DESCRIPTION:

Start value when operating the wheel.

COMMONLY USED AND RECOMMENDED SETTING:

0%.

6.5.3. **Linear 0...100% / upper limit (%)**

PROPERTIES:

0 to 100%.

DESCRIPTION:

End value when operating the wheel.

COMMONLY USED AND RECOMMENDED SETTING:

100%.

6.5.4. **Linear 1 byte, 0...255 / lower limit**

PROPERTIES:

0 to 255.

DESCRIPTION:

Start value when operating the wheel.

COMMONLY USED AND RECOMMENDED SETTING:

0.

6.5.5. **Linear 1 byte, 0...255 / upper limit**

PROPERTIES:

0 to 255.

DESCRIPTION:

End value when operating the wheel.

COMMONLY USED AND RECOMMENDED SETTING:

255.

6.5.6. **Linear 2 byte, 0...65535 / lower limit**

PROPERTIES:

0 to 65535.

DESCRIPTION:

Start value when operating the wheel.

COMMONLY USED AND RECOMMENDED SETTING:

0.

6.5.7. **Linear 2 byte, 0...65535 / upper limit**

PROPERTIES:

0 to 65535.

DESCRIPTION:

End value when operating the wheel.

COMMONLY USED AND RECOMMENDED SETTING:

65535.

6.5.8. **Linear 2-byte-float / lower limit basis (-20000...20000)**

PROPERTIES:

-20,000 to 20,000.

DESCRIPTION:

Start value when operating the wheel.

COMMONLY USED AND RECOMMENDED SETTING:

Object-dependant.

6.5.9. **Multiplier**

PROPERTIES:

x 0.1 or x 1.0

DESCRIPTION:

Fine adjustment of values from the lower limit.

COMMONLY USED AND RECOMMENDED SETTING:

1.0.

6.5.10. **Linear 2-byte-float / upper limit basis (-20000...20000)**

PROPERTIES:

-20,000 to 20,000

DESCRIPTION:

End value when operating the wheel.

COMMONLY USED AND RECOMMENDED SETTING:

Object-dependant.

6.5.11. **Multiplier**

PROPERTIES:

x 0.1 or x 1.0

DESCRIPTION:

Fine adjustment of values from the lower limit.

COMMONLY USED AND RECOMMENDED SETTING:

1.0.

6.5.12. **Minimum telegramme interval upon manually change of values on the wheel (ms)**

PROPERTIES:

50 to 500.

DESCRIPTION:

The wheel's linear regulation leads to corresponding telegrammes and to a corresponding bus charge. In order to find the suitable setting according to the system's configuration and performance as well as user friendliness, the telegrammes' interval is set variably.

COMMONLY USED AND RECOMMENDED SETTING:

150 ms.

6.5.13. **Linear 4-byte-float**

Same settings as „Linear 2-byte-float“.

6.5.14. **Colour of active segments**

PROPERTIES:

See „LED-colours of key“, see „Main function of the wheel“

DESCRIPTION:

Determination of the preferred wheel LED colour.

COMMONLY USED AND RECOMMENDED SETTING:

Like LED-colours of the keys. The function „channel selection“ via touch areas is also optically made clearly visible.

6.6. **LED 1 (upper left corner)**

The basic settings for the lighting of kamereon's upper left touch area (LED1) are stored in the parameter dialogue.

6.6.1. **Day-mode basic colour of the LEDs**

PROPERTIES:

Off, Cyan, Magenta, Blue, Yellow, Green, Red and White.

DESCRIPTION:

Colour of all LEDs with selection of master operation.

COMMONLY USED AND RECOMMENDED SETTING:

Blue.

Important note:

Depending on kamereon's background colours have a different impact. For example in a piano black kamereon the colour magenta does not appear as brilliant as in a snow mountain white kamereon. Individual backgrounds also have an influence on the appearance of the LEDs. Therefore it is possible to mix colours via 3 byte RGB object exactly according to customers' requirements and then transfer it to the kamereon.

6.6.2. **Day-mode colour at key touch**

PROPERTIES:

Off, Cyan, Magenta, Blue, Yellow, Green, Red and White.

DESCRIPTION:

Colour of all LEDs upon random key touch.

COMMONLY USED AND RECOMMENDED SETTING:

Off.

6.6.3. **Day-mode colours at ON-telegramme**

PROPERTIES:

Off, Cyan, Magenta, Blue, Yellow, Green, Red and White.

DESCRIPTION:

colour of all LEDs with respective object value „On“.

COMMONLY USED AND RECOMMENDED SETTING:

Off.

6.6.4. **Day mode colour at OFF-telegramme**

PROPERTIES:

Off, Cyan, Magenta, Blue, Yellow, Green, Red and White.

DESCRIPTION:

Colour of all LEDs with respective object value „Off“.

COMMONLY USED AND RECOMMENDED SETTING:

Off.

6.6.5. **Shut-off delay of LED after activation via key touch**

PROPERTIES:

Basic colour after releasing the key, 1 to 10 seconds, 1, 2, 5, 10, 15 and 30 minutes, 1 hour, change upon operation/telegramme.

DESCRIPTION:

Determines the shut-off delay (persistence time) of the respective LEDs. The shut-off delay is also influenced by the time itself as well as by other activities like „Releasing the key“, other telegrammes, and so on, as required.

APPLICATION:

kamereon offers a very extensive colour scheme for the LED areas, corresponding to the operation philosophy. For example:

- Lighting object

kamereon is installed as a lighting object and its operation is to be intuitively via the LED areas. The upper left key is backlit in green for scene 1 „Entering“, the upper right key is backlit in blue for scene 2 „Day-mode“, the lower left key is backlit in red for scene 3 „Night-mode“ and the lower right key is backlit in yellow for scene 4 „Leaving“. The colour upon touching the key is magenta. In addition „Basic colour after releasing the key“ is set respectively for every key. The user receives a positive feedback via vibration/click as well as optically by seeing the colour magenta. Upon releasing the touch areas, kamereon illuminates them again according to the preset light object..

- Trained status objects

Another operating philosophy follows the trained colour schemes of „On“ = „green“ and „Off/Stand-by“ = „red“. When using this concept the basic colour remains off and the user recognizes immediately by seeing the colours red and green the status of the system resp. of the device.

COMMONLY USED AND RECOMMENDED SETTING:

Change upon operation/telegramme.

Important note:

Colours can not only help the user to operate complex systems but they can also be very inspiring. However, a full exhaustion of all of kamereon's possibilities does not necessarily lead to a helpful support for the user. In other words: if the options basic colour, colour upon key touch, colour at ON-telegramme and colour at OFF-telegramme are set and active, the user does probably not easily understand his own intelligent home system.

6.6.6. Same colours and shut-off delays of LEDs in day- and in night-mode?

PROPERTIES:

Yes / No.

DESCRIPTION:

Via an object it is possible to have kamereon change the entire colour scheme including shut-off delays of the colours between two programmes. This can be done either in a private environment, for example deactivating all colours in night-mode. In other objects a more reddish colour scheme was used for outdoor temperatures above 30 °C and a blue colour scheme for lower temperatures. Other examples for different colour schemes are wellness and spa areas, supportive arrangements for the human biorhythm, and many more. Contrary to the master operation the LEDs of the respective touch areas are addressed.

When switching value „0“ activates the day mode and value „1“ activates the night mode.

COMMONLY USED AND RECOMMENDED SETTING:

Object-dependant. No clear recommendation.

6.6.7. Activation of day mode via key touch

PROPERTIES:

No local activation, activation upon key touch, activation after shut-off delay.

DESCRIPTION:

kamereon's day/night modes represent two different colour schemes. The change between these two modes can be done via objects of the KNX bus or locally by operating the switch.

DESCRIPTION:

It is possible in several ways to obtain different levels of brightness and/or different colour schemes if desired while operating the kamereon switch. For example different levels of brightness between operation and stand-by: After 60 minutes kamereon is to dim the LEDs to 5% brightness, increase the brightness to 60% upon operation and then leave it at 30% for 5 more minutes. In the „general“ tab the stand-by is therefore set to 60 minutes and brightness to 5%, the „shut-off delay of LED after activation via key touch“ is set to 5 minutes, „activation of day-mode via key touch“ is set on „activation upon key touch“, „activation night-mode via key touch“ is set to „activation with shut-off delay“, „LEDs brightness in day-mode (%)“ is set to 60% and „LEDs brightness in night-mode (%)“ is set to 30%. Please note that the setting is then exclusively made for the LEDs of the respective touch area.

For switching between day- and night-mode the setting „Same colours and shut-off delays in day- and

night-mode“ has to be set to „No“.

COMMONLY USED AND RECOMMENDED SETTING:

No local activation. Switching is generally done via objects, for example via a brightness-controlled object of a visualization. A similiar programming of all touch areas is often felt as more comfortable.

6.6.8. **Activation of night mode via key touch**

PROPERTIES:

No local activation, activation upon key touch, activation after shut-off delay.

DESCRIPTION:

kamereon’s day- / night-modes represent two different colour schemes. The change between these two modes can be done via objects of the KNX bus or locally by operating the switch.

DESCRIPTION:

It is possible in several ways to obtain different levels of brightness and/or different colour schemes if desired while operating the kamereon switch. For example different levels of brightness between operation and stand-by. Please see also the example above „Activation of day-mode via key touch“.

COMMONLY USED AND RECOMMENDED SETTING:

No local activation. Switching is generally done via objects, for example via a brightness-controlled object of a visualization.

6.6.9. **LEDs brightness in day-mode (%)**

PROPERTIES:

0 to 100%.

DESCRIPTION:

Light intensity of all LEDs.

COMMONLY USED AND RECOMMENDED SETTING:

60% with piano black and 40% with snow mountain white.

6.6.10 **LEDs brightness in night-mode (%)**

PROPERTIES:

0 to 100%.

DESCRIPTION:

Light intensity of all LEDs.

COMMONLY USED AND RECOMMENDED SETTING:

15% with piano black and 5% with snow mountain white.

6.6.11 **Colour of the LED when locked**

PROPERTIES:

Off, Cyan, Magenta, Blue, Yellow, Green, Red and White.

DESCRIPTION:

kamereon's operation can either be locked completely or selectively. The colour which represents the locked touch areas is freely selectable.

COMMONLY USED AND RECOMMENDED SETTING:

Red.

6.6.12 Specification of colours/shut-off delays/brightness by objects

PROPERTIES:

Yes / No.

DESCRIPTION:

Apart from the quick and easy setting of kamereon via the parameter dialogue it is generally possible to determine or change all properties via objects, for example further possibilities such as mixing RGB-colours.

COMMONLY USED AND RECOMMENDED SETTING:

No clear rule. Frequently used in systems with visualization is option „Yes“.

6.7. Key 2 (upper right corner)

Identical to key no. 1.

6.8. LED 2 (upper right corner)

Identical to LED no. 1.

6.9. Key 3 (lower left corner)

Identical to key no. 1.

6.10. LED 3 (lower left corner)

Identical to LED no. 1.

6.11. Key 4 (lower right corner)

Identical to key no. 1.

6.12. LED 4 (lower right corner)

Identical to LED no. 1.

6.13. Key 5 (center)

Identical to key no. 1.

6.14. **Main function of the wheel**

PROPERTIES:

Not used, via short key touch, via long key touch.

DESCRIPTION:

Special function of key no. 5. Contrary to keys 1 to 4 it does not choose a „channel“ but the wheel responds as an independent touch area.

COMMONLY USED AND RECOMMENDED SETTING:

Object-dependant.

6.14.1. **Type of output telegramme**

PROPERTIES:

Linear 0...100%, Linear 1 byte, 0...255, Linear 2 byte, 0...65536, Linear 2-byte-float, Linear 4-byte-float.

DESCRIPTION:

According to the clockwise touch operation the respective output values will be given. The values of the wheel are increased clockwise. Values can either be jumped to or approached. In the setting „Linear 0...100%“ „jumping to“ 3:00 o'clock corresponds to „approaching to“ 25% !

COMMONLY USED AND RECOMMENDED SETTING:

Linear 0...100%.

6.14.2. **Linear 0...100% / lower limit (%)**

PROPERTIES:

0 to 100%.

DESCRIPTION:

Start value when operating the wheel.

COMMONLY USED AND RECOMMENDED SETTING:

0%.

6.14.3. **Linear 0...100% / upper limit (%)**

PROPERTIES:

0 to 100%.

DESCRIPTION:

End value when operating the wheel.

COMMONLY USED AND RECOMMENDED SETTING:

100%.

6.14.4. **Linear 1 byte, 0...255 / lower limit**

PROPERTIES:

0 to 255.

DESCRIPTION:

Start value when operating the wheel.

COMMONLY USED AND RECOMMENDED SETTING:

0.

6.14.5. **Linear 1 byte, 0...255 / upper limit**

PROPERTIES:

0 to 255.

DESCRIPTION:

End value when operating the wheel.

COMMONLY USED AND RECOMMENDED SETTING:

255.

6.14.6. **Linear 2 byte, 0...65535 / lower limit**

PROPERTIES:

0 to 65535.

DESCRIPTION:

Start value when operating the wheel.

COMMONLY USED AND RECOMMENDED SETTING:

0.

6.14.7. **Linear 2 byte, 0...65535 / upper limit**

PROPERTIES:

0 to 65,535.

DESCRIPTION:

End value when operating the wheel.

COMMONLY USED AND RECOMMENDED SETTING:

65,535.

6.14.8. **Linear 2-byte-float / lower limit basis (-20000...20000)**

PROPERTIES:

-20,000 to 20,000

DESCRIPTION:

Start value when operating the wheel.

COMMONLY USED AND RECOMMENDED SETTING:

Object-dependant.

6.14.9. **Multiplier**

PROPERTIES:

x 0.1 or x 1.0

DESCRIPTION:

Fine adjustment of values from the lower limit.

COMMONLY USED AND RECOMMENDED SETTING:

1.0.

6.14.10. **Linear 2-byte-float / upper limit basis (-20000...20000)**

PROPERTIES:

-20,000 to 20,000

DESCRIPTION:

End value when operating the wheel.

COMMONLY USED AND RECOMMENDED SETTING:

Object-dependant.

6.14.11. **Multiplier**

PROPERTIES:

x 0.1 or x 1.0

DESCRIPTION:

Fine adjustment of values from the lower limit.

COMMONLY USED AND RECOMMENDED SETTING:

1.0.

6.14.12. **Minimum telegramme interval upon manual change of values on the wheel (ms)**

PROPERTIES:

50 to 500

DESCRIPTION:

The wheel's linear regulation leads to corresponding telegrammes and to a corresponding bus charge. In order to find the suitable setting according to the system's configuration and performance as well as user friendliness, the telegrammes' interval is set variably.

COMMONLY USED AND RECOMMENDED SETTING:

150 ms.

6.14.13. Linear 4-byte-float

Same settings as Linear 2-byte-float.

6.14.14. 4-segment-operation

PROPERTIES:

4-segment-operation.

DESCRIPTION:

Special function via key no. 5 (centre) in combination with the wheel. In order to help the user operate complex systems simply and intuitively, kamereon comes with 4 colour circle segments. For example a blue circle segment between 0 and 3 o'clock can be allocated to the scene „Party“, a green circle segment between 3 and 6 o'clock to the scene „Living“, a red circle segment between 6 and 9 o'clock to the scene „Evening“ and a yellow circle segment between 9 and 0 o'clock can be allocated to the scene „Reading“. The respective programming of the scene can be changed for example by integrating free standing luminaires. The user however keeps his familiar scene „Reading“, represented in yellow.

The numbering of the segments corresponds to the numbering of the keys. This means that segment 1 is in the upper left corner (09:00 o'clock to 12:00 o'clock), segment 2 in the upper right corner (12:00 o'clock to 03:00 o'clock), segment 3 in the lower right corner (03:00 o'clock to 06:00 o'clock) and segment 4 in the lower left corner (06:00 o'clock to 09:00 o'clock). The 4-segment-operation reacts to changes in values. This means that the optimal operation is done by gently sweeping within the segments instead of tapping.

COMMONLY USED AND RECOMMENDED SETTING:

Object-dependant.

6.14.15. Colour of segment 1 upon activation of segment operation

PROPERTIES:

Off, Cyan, Magenta, Blue, Yellow, Green, Red and White.

DESCRIPTION:

Colour of the circle segment between 09:00 o'clock and 12:00 o'clock.

COMMONLY USED AND RECOMMENDED SETTING:

Cyan.

6.14.16. Colour of segment 2 upon activation of segment operation

PROPERTIES:

Off, Cyan, Magenta, Blue, Yellow, Green, Red and White.

DESCRIPTION:

Colour of the circle segment between 12:00 o'clock and 03:00 o'clock.

COMMONLY USED AND RECOMMENDED SETTING:

Magenta

6.14.17. Colour of segment 3 upon activation of segment operation

PROPERTIES:

Off, Cyan, Magenta, Blue, Yellow, Green, Red and White.

DESCRIPTION:

Colour of the circle segment between 03:00 o'clock and 06:00 o'clock.

COMMONLY USED AND RECOMMENDED SETTING:

Blue.

6.14.18. Colour of segment 4 upon activation of segment operation

PROPERTIES:

Off, Cyan, Magenta, Blue, Yellow, Green, Red and White.

DESCRIPTION:

Colour of the circle segment between 06:00 o'clock and 09:00 o'clock.

COMMONLY USED AND RECOMMENDED SETTING:

Yellow.

6.14.19. Colour of segment 1 upon operation

PROPERTIES:

Same as LED-colours of the key. Same as LED-colour of the wheel's main function.

DESCRIPTION:

Colour of the circle segment between 09:00 o'clock and 12:00 o'clock upon operation.

COMMONLY USED AND RECOMMENDED SETTING:

Same as LED-colours of the key.

6.14.20. Colour of segment 2 upon operation

PROPERTIES:

Same as LED-colours of the key. Same as LED-colour of the wheel's main function.

DESCRIPTION:

Colour of the circle segment between 12:00 o'clock and 03:00 o'clock upon operation.

COMMONLY USED AND RECOMMENDED SETTING:

Same as LED-colours of the key.

6.14.21. **Colour of segment 3 upon operation**

PROPERTIES:

Same as LED-colours of the key. Same as LED-colour of the wheel's main function.

DESCRIPTION:

Colour of the circle segment between 03:00 o'clock and 06:00 o'clock upon operation.

COMMONLY USED AND RECOMMENDED SETTING:

Same as LED-colours of the key.

6.14.22. **Colour of segment 4 upon operation**

PROPERTIES:

Same as LED-colours of the key. Same as LED-colour of the wheel's main function.

DESCRIPTION:

Colour of the circle segment between 06:00 o'clock and 09:00 o'clock upon operation.

COMMONLY USED AND RECOMMENDED SETTING:

Same as LED-colours of the key.

6.14.23. **Minimum telegramme interval upon manual change of values on the wheel (ms)**

PROPERTIES:

50 to 500

DESCRIPTION:

The wheel's linear regulation leads to corresponding telegrammes and to a corresponding bus charge. In order to find the suitable setting according to the system's configuration and performance as well as user friendliness, the telegrammes' interval is set variably.

COMMONLY USED AND RECOMMENDED SETTING:

150 ms.

6.15. **LEDs of the wheel**

Same settings as LEDs of the keys.

6.16. **Segment 1 - only active upon 4-segment-operation**

Same settings as key 1.

6.17. **Segment 2 - only active upon 4-segment-operation**

Same settings as key 1.

6.18. **Segment 3 - only active upon 4-segment-operation**

Same settings as key 1.

6.19. **Segment 4 - only active upon 4-segment-operation**

Same settings as key 1.

6.20. **Temperature**

Temperature measurement is implemented only via the integrated detector, as a calculated value from the internal detector + a further detector or via an external detector. The selection is made in ETS. When using an external detector the factor for allowance can be determined in steps of 5% (from 5% to 95%).

The internal detector can be aligned and/or corrected via the parameter settings in ETS (+/- by 0.1 Kelvin). In addition the limits are set for sending temperature changes (0, Kelvin) as well as, if necessary, the cyclical transmission.

6.20.1 **Telegramme interval temperature**

PROPERTIES:

No cyclical transmission, 1 second, 1 minute, 1 hour.

DESCRIPTION:

Frequency of temperature transmission. In context with „Transmission of temperature from a difference of (°C*0,1 0=Deactivated).

COMMONLY USED AND RECOMMENDED SETTING:

No cyclical transmission.

6.20.2. **Offset temperature (°C * 0.1)**

PROPERTIES:

-2000 to 2000.

DESCRIPTION:

Due to structural or thermodynamic conditions an adjustment to the actual room temperature may be necessary.

COMMONLY USED AND RECOMMENDED SETTING:

Object-dependant.

Important note:

Using kamereon as a lighting object, it's 24 RGB-LEDs develop some internal heat. This has a certain impact on the temperature detection. Further measuring points may become necessary.

6.20.3. **Transmission of “temperature” from a difference of (°C * 0.1, 0=Deactivated)**

PROPERTIES:

0 to 2000.

DESCRIPTION:

Apart from the setting „cyclical transmission“ this is an important menu item for determining when and why certain information about a temperature is being sent. This is where the granularity for the transmission of values is set.

COMMONLY USED AND RECOMMENDED SETTING:

5. Equals 0.5°C of temperature change.

6.20.4. **Internal temperature basis (0...100)**

PROPERTIES:

0 to 100.

DESCRIPTION:

kamereon can process both internal and external temperatures. The „mixing ratio“ is determined by the following points.

COMMONLY USED AND RECOMMENDED SETTING:

1. Herewith only the internal temperature is used with the multiplier 1.

6.20.5. **Multiplier**

PROPERTIES:

x 0.1 and x 1.0.

DESCRIPTION:

kamereon can process both internal and external temperatures. The „mixing ratio“ is determined by the following points.

COMMONLY USED AND RECOMMENDED SETTING:

1.0. Herewith only the internal temperature is used for regulation.

6.20.6. **Processing of the external temperature**

PROPERTIES:

Yes / No.

DESCRIPTION:

kamereon can process both internal and external temperatures. This is where the selection is made.

COMMONLY USED AND RECOMMENDED SETTING:

No.

6.20.7. **External temperature basis (0...100)**

PROPERTIES:

0 to 100.

DESCRIPTION:

kamereon can process both internal and external temperatures. The „mixing ratio“ is determined by the following points.

COMMONLY USED AND RECOMMENDED SETTING:

0.5.

6.20.8. **Multiplier**

PROPERTIES:

x 0.1 and x 1.0.

DESCRIPTION:

kamereon can process both internal and external temperatures. The „mixing ratio“ is determined by the following points.

COMMONLY USED AND RECOMMENDED SETTING:

0.5. With this setting the internal and external temperatures are mixed in equal parts for regulation.

6.20.9. **Performance when locking the temperature**

PROPERTIES:

Locking deactivated, transmitting actual temperature, transmitting preset temperature.

DESCRIPTION:

A frequently imposed requirement with combined regulations (cooling, heating) or with special usage of space is to deactivate the integrated temperature regulation. This possibility as well as the behaviour of kamereon can be set in this menu item.

COMMONLY USED AND RECOMMENDED SETTING:

Locking deactivated.

6.21. **PI. controller**

Basic configuration of the way of temperature regulation. kamereon has been developed for a basic temperature regulation via „Heating“.

6.21.1. **Nominal value/set point (°C)**

PROPERTIES:

1 to 60

DESCRIPTION:

Desired temperature value.

COMMONLY USED AND RECOMMENDED SETTING:

22.

6.21.2. **Control parameters**

PROPERTIES:

Via parameter dialogue, split-unit, fan coil, electric heating, underfloor heating, hot water heating.

DESCRIPTION:

Determines the controller algorithm depending on the heating system in use.

COMMONLY USED AND RECOMMENDED SETTING:

Object-dependant.

6.21.3. **Proportional range (°C * 0.1)**

PROPERTIES:

0 to 255.

DESCRIPTION:

With a pure P controller the controlled valuable responds precisely equable to the control deviation. This control behaviour can be increased or reduced in the control section.

COMMONLY USED AND RECOMMENDED SETTING:

50.

6.21.4. **Reset time (min.)**

PROPERTIES:

0 to 255.

DESCRIPTION:

Reset time is the time measure, of how much the regulation is influenced by the control deviation.

COMMONLY USED AND RECOMMENDED SETTING:

150.

7.0 Examples

7.1. Day-/night mode for different RGB-configurations of kamereon

The day- / night-mode can not only be used for different colours or light intensities of the RGB-illumination for kamereon. It is also possible to create different interpretations of the kamereon switch.

In the following example only the four outer illuminated areas are to be seen during day mode whereas in night mode only the wheel is to be illuminated.

LED-areas 1 to 4 have any random colour in day-mode and none in night-mode.

Configuration of the wheel is exactly the opposite. No colour in day-mode and a random colour in night-mode. In addition objects 27, 48, 69, 90 and 111 have to be allocated with the group address for the switching between day- / night-mode.

For ETS 5 exemplary project please see www.dakanimo.com

