

KNX Metering gateway

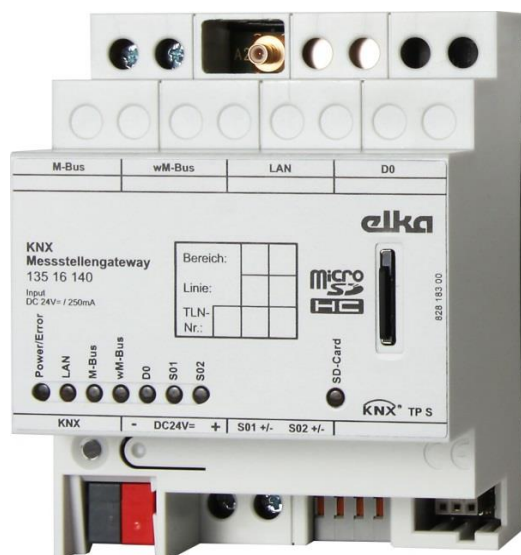

1	Description of functions	4
2	Hardware description	5
2.1	Device configuration	5
2.2	Status displays.....	5
2.3	Technical data	7
3	KNX Metering gateway	8
3.1	Interfaces	8
3.1.1	KNX	8
3.1.2	M-Bus	8
3.1.3	wM-Bus.....	8
3.1.4	S0	9
3.1.5	D0.....	9
3.1.6	LAN.....	9
3.1.7	Micro-SD-card	9
4	Software description.....	10
4.1	Software specification.....	10
4.2	ETS configuring and commissioning	10
4.3	Description of functions	10
4.3.1	General.....	10
4.3.1.1	KNX	10
4.3.1.2	SD-card.....	11
4.3.1.3	Date and time	13
4.3.1.4	Network.....	14
4.3.2	Aquisition of measuring values	15
4.3.2.1	Activation	15
4.3.2.2	S0	16
4.3.2.3	D0	18
4.3.2.4	M-Bus and wM-Bus	19
4.4	Web-server	21
4.4.1	Meter	23
4.4.2	Meter search	24
4.4.3	Device information.....	26
5	Appendix	27
5.1	M-Bus	27
5.1.1	Structure	27
5.1.2	Addressing	27
5.1.3	Installation	27
5.1.4	Data transmission.....	27
5.2	Wireless M-Bus.....	28
5.2.1	Addressing	28
5.2.2	Installation	28
5.2.3	Data transmission.....	28
5.3	S0.....	28
5.3.1	Devices.....	28
5.3.2	Installation	29
5.3.3	Data transmission.....	29
5.4	D0	29
5.4.1	Devices.....	29
5.4.2	Installation	29
5.4.3	Data transmission.....	29
5.5	KNX.....	29
5.5.1	Structure	30
5.5.2	Installation	30
5.5.3	KNX devices.....	30
5.5.4	Data transmission.....	30
5.6	Legal notices.....	31

All rights to this document and the included texts and figures are reserved. Copying, dissemination or use of the contents, also extracts of it, is not allowed without prior written consent.

© 2016 ELKA-Elektronik GmbH

1 Description of functions

The *KNX metering gateway* is an intelligent DIN-rail mounted system device for coupling of metering systems with M-Bus, wireless-M-Bus, D0- or S0-interfaces to the KNX/EIB. The gateway requires a 24 V DC supply voltage.



For connection of the *KNX metering gateway* the mounting and operating instructions must be observed.

The functionality of the *KNX metering gateway* is set by programming.

The *KNX metering gateway* records meters with wM-Bus-, M-Bus-, D0- or S0-interface and passes on these data to the KNX. Here the gateway adopts the role of the M-Bus master, i.e. it controls the communication. Depending on the measuring value, different data formats can be set.

Via the integrated Web-server up to 20 M-Bus-meters are connected and the readings are displayed. The data sent by the meter are displayed in detail in plain text, so a time-consuming procurement of M-bus telegram descriptions can be dispensed with. Parameterisation of the *KNX metering gateway* is effected via ETS4/ETS5.

The gateway is realised as DIN-rail mounted device and supplied with 24V DC. M-Bus TP is connected via screw terminals, the KNX TP connection is effected via bus terminal. For the wireless M-Bus connection (wM-Bus) a radio antenna is available which can be ordered separately. The D0 signals are read via a D0 receiver head which is connected to the gateway via an RJ10 interface. For two S0 signals a 4-pole plug-in terminal is available. Via the SD-card slot at the front side measuring data can be written on a Micro-SD-card and can thus be used by the user for further statistics at the PC. Via the status-LEDs at the front side of the gateway the states of the different interfaces are signalled optically. The *KNX metering gateway* is designed for maintenance-free operation without fan and other wearing parts.

2 Hardware description

2.1 Device configuration

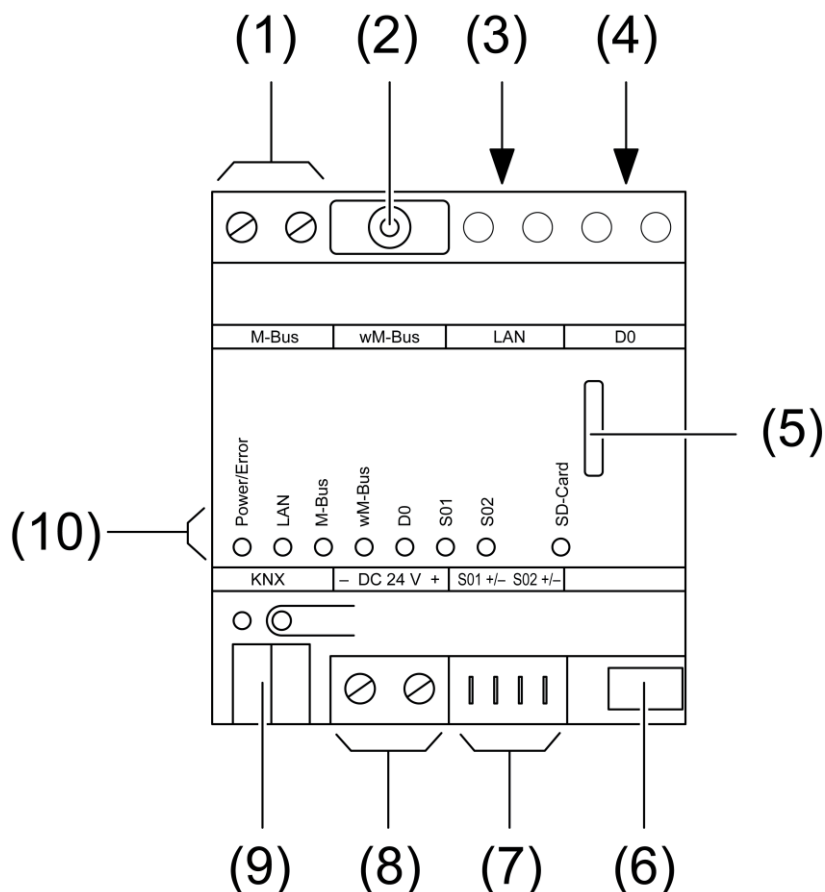

Fig. 2-1: Device configuration

- (1) Port for M-Bus devices
- (2) Port for wM-Bus antenna
- (3) Ethernet port
- (4) D0 port for optical reading head
- (5) Slot for Micro-SD-card
- (6) For future extensions, without function
- (7) two S0-connections
- (8) External supply
- (9) KNX port
- (10) Status LED

2.2 Status displays

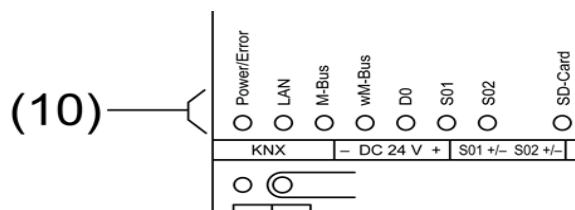

Fig. 2-2: Status LED

The LED show the status of devices and communication. Depending on the direction of communication, the LED signals may superimpose or be shown only for a short time.

Power/Error	Red: internal error Red flashing: error with KNX commissioning Yellow: external commissioning (meter scan) active Yellow flashing: commissioning, parameters are being loaded Green: normal operation Green/Red flashing: updated firmware of micro-SD-card is being loaded
LAN	Yellow flickering: data transfer via Ethernet port
M-Bus	Red: no meter found in commissioning. Red flashing: Too little memory space for all M-Bus and wM-Bus-meters Yellow: data reception Green: transmitting
wM-Bus	Red: internal error Yellow: receiving Green: initialisation
D0	Red: error while receiving Yellow: receiving
S01, S02	Yellow flashing (approx. 1.2 seconds): impulse detected
SD-card	Red: writing on SD-card not possible. Red flashing: SD-card full Yellow flashing: reading from SD-card Green flashing: writing on SD-card

2.3 Technical data

External supply

Rated voltage	DC 24 V SELV ($\pm 10\%$)
Power consumption	max. 6.5 W

Ambient conditions

Ambient temperature	- 5 °C to + 45 °C
Storage and transport temp.	- 25 °C to + 70 °C

Humidity
(ambient / transport / storage)

Protection class	III
Installation width	72 mm / 4 modules
Weight	approx. 175 g

Network communication

Bit rate IP	10 / 100 Mbit/s
Ethernet/IP port	RJ45 socket

KNX

KNX medium	TP 1
Commissioning mode	S-mode
Rated voltage KNX	DC 21 V ... 32 V SELV
KNX port	Standard KNX / EIB bus terminals
Power consumption KNX	typ. 150 mW

3 KNX Metering gateway

3.1 Interfaces

The *KNX metering gateway* has different interfaces to receive measuring values from different meters and to pass them on to other systems.

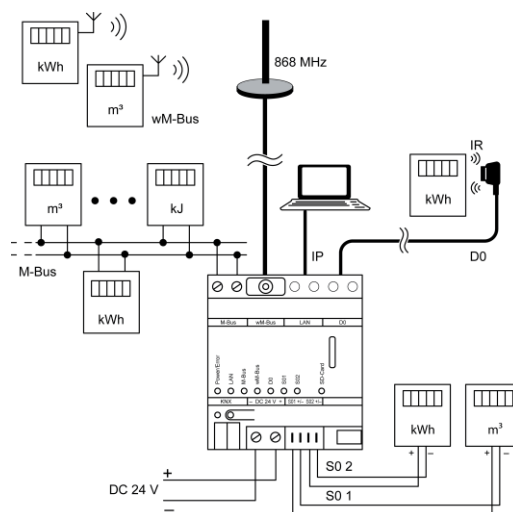

Fig. 3-1: Survey of interfaces

3.1.1 KNX

The KNX connection is effected via a standard KNX bus terminal (9).

It is used for commissioning and for displaying the current and historical measuring values.

3.1.2 M-Bus

The wired M-Bus connection is effected via screw terminals (1). It allows the connection of up to 20 meters (under consideration of the simultaneously used wM-Bus meters).

3.1.3 wM-Bus

The antenna for wM-Bus is connected via the socket contact (2). For positioning of the antenna outside the distribution board and for laying the antenna cable, a save separation of the other voltages must be provided.

The transmission quality depends on the distance to the measuring point and on the transmission field intensity of the measuring point. To provide a good transmission quality, please keep enough distance

to possible interference sources, e.g. metallic surfaces, microwave ovens, Hi-fi and TV systems, ballasts or transformers.

3.1.4 S0

Connection of up to two S0-measuring points is effected via the plug-in terminal (7), for instance with a cable J-Y(St)Y 2x2x0.8. Only measuring points with save separation to other voltages are allowed.

3.1.5 D0

Connection of the optical communication head for D0 is effected via the RJ10-socket (4).

3.1.6 LAN

Connection to the network or to the PC is effected via the RJ45-socket LAN (3).

For direct connection of a PC it might be necessary to use a crosslink network cable.

3.1.7 Micro-SD-card

By inserting a micro-SD-card, measuring values can be stored on site. The memory card can be read by a card reader. Max. file size: 4 GB.

The micro-SD card must be formatted with the system FAT32. After being inserted into the slot (5) it is detected by the device automatically.

In order to avoid data losses, the micro-SD-card must not be removed while writing (while the LED *SD-card* blinks green).

4 Software description

4.1 Software specification

ETS search path	Gateways / Gateway measuring data collection / KNX metering gateway wM-Bus, M-Bus
Configuration	S-mode standard
AST-Type	no AST
AST connection:	no connector
Mask version:	70B
Name:	metering gateway C01911
Version:	1.0 for ETS as from version 4.2.0

4.2 ETS configuring and commissioning

Configuring and commissioning of the *KNX metering gateway* are effected by means of ETS as from version 4.2.0.

4.3 Description of functions

The *KNX metering gateway* receives the measuring values of the connected meters and displays these values via KNX or the integrated Web-server and optionally stores the values on a micro-SD-card.

4.3.1 General

4.3.1.1 KNX

Transmission delay on supply voltage return	5 sec
Transmission pause after last meter	10 min
Transmission pause between individual meters	0.2 sec
Transmission pause between individual datasets	0.1 sec

Fig. 4-1: Parameters KNX

After switching on the supply voltage, the *KNX metering gateway* waits for the *Transmission delay on supply voltage return* set, before it sends to KNX telegrams. The time when valid meter values are

available depends on the number of connected meters and data points used.

In case of bus voltage failure and bus voltage return there is no special reaction.

Normally, the *KNX metering gateway* sends the received measuring values cyclically to the KNX. With the parameters *transmission pause between individual datasets*, *transmission pause between individual meters*, *transmission pause after last meter*, the bus load can be controlled.

These settings of cyclical transmission are valid for all datasets, for which *Transmit on change by value* is not explicitly set.

4.3.1.2 SD-card

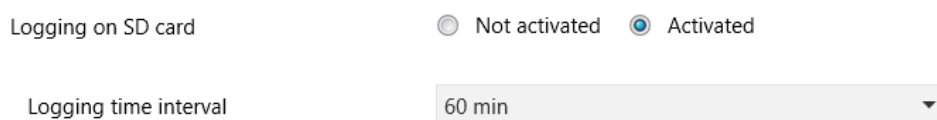

Fig. 4-2: Parameters SD-card

The *KNX metering gateway* can store all measuring values on a micro-SD-card, if the parameter *Logging on SD card* is *activated*.

The micro-SD-card can be inserted into the *KNX metering gateway* any time.

If saving of the measuring values is activated, the *KNX metering gateway* checks with run-out of each set *time interval*, whether a memory card is inserted. If a memory card is inserted, the LED *SD-card* starts flashing green. After saving, the LED goes out. If there is not enough space left on the memory card, the LED flashes red. If no memory card is inserted, the LED *SD-card* shines red.

The memory card can be removed, if no writing is under way and the LED *SD-card* is not flashing green. Removal of the memory card during writing may damage the data saved.

The data are saved in text files. After each time interval a new line is written. Within one line, the individual data are divided by a semicolon.

With the file *ELKA.TXT* the *KNX metering gateway* checks whether the micro-SD-card can be used.

In the files *S01.TXT* and *S02.TXT* the values of the two S0 interfaces are stored. The entries in these files have the following format:

Year; Month; Day; Hour; Minute; S0; Interface; data record;
Measuring value; Unit

In the file *D01.TXT* the values of the D0-interface are stored. The entries in this file have the following format:

Year; Month; Day; Hour; Minute; D0; Interface; Data record;
Measuring value; Unit; OBIS-identification.

In the OBIS-identification, for instance, the units of the measuring values and the tariffs are coded.

In the file *MBUS.TXT* the M-Bus and wM-Bus meters are listed, which were found with the last meter search. For the meters which were configured in the ETS, also the meter number is recorded. The meter number can be used to identify the file *MBUSxx.TXT* belonging to the meter.

In the files *MBUSxx.TXT* the values of the M-Bus and wM-Bus meters are stored. The entries in these files have the following format:

Year; Month; Day; Hour; Minute; MBus; Meter number; Data record;
Measuring value; Unit; Tariff; Measuring mode.

The tariff is indicated as figure. The value 0 stands for standard tariff.

The measuring mode is indicated as follows:

- 0 Current value
- 1 Max value
- 2 Min value
- 3 Error value

4.3.1.3 Date and time

Time zone	<input type="text" value="UTC+1h: Amsterdam, Berlin, Berne, Rome, Stoc..."/>
Date and time	<input type="radio"/> Request via KNX <input checked="" type="radio"/> Request from time server
URL time server	<input type="text" value="1.de.pool.ntp.org"/>
Automatic summer/winter time changeover	<input type="radio"/> Not activated <input checked="" type="radio"/> Activated

top

Fig. 4-3: Parameters Date and Time

For proper logging of the measuring values, correct date and time information are indispensable. Synchronisation of the internal clock can be effected via KNX or via an NTP server.

If the parameter *Date and Time* is set to *Request via KNX*, the communication objects *Request time/date*, *Setting time* and *Setting the date* are displayed. After a reset, the *KNX meter gateway* once sends a telegram via the communication object *Request time/date*. The *KNX metering gateway* then receives the current values via the communication objects *Setting the date* and *Setting time*. During operation, the internal clock is synchronised on each receipt of the communication objects *Setting the date* and *Setting time*.

If the parameter *Date and Time* is set to *Request via Time-Server*, the parameter *URL Timeserver* is displayed. Here an NTP server must be registered which preferably comes from the same country and which is constantly accessible, e.g. 1.de.pool.ntp.org.

In order to adapt the information of the time server to the local time, the parameter *Time zone* is necessary. Optionally, also the parameter *Automatic summer/winter time changeover* can be activated.

If the communication object *Master clock time/date request* receives a telegram with the value „1“, the objects *Master clock time* and *Master clock date* send telegrams to synchronise other devices.

4.3.1.4 Network

Configuration of network Use static IP address Use DHCP server

Web server Not activated Activated

Language of website German English

Password for website

Approved characters: 0-9 a-z A-Z ! " \$ % & / \ () ? = + - * ~ # _ . : ; < > [] [] @ ^

Fig. 4-4: Parameters Network

To be able to use the complete scope of functions of the *KNX metering gateway*, it must be integrated into a network. To this effect, a valid IP-address is necessary.

The parameter *Configuration of network* determines whether the *KNX metering gateway* receives its network address automatically from a DHCP-server, or whether it uses a static IP-address.

In case of an automatic assignment, the current IP-address of the *KNX metering gateway* must be taken out of the address table of the DHCP-server. If a Micro-SD-card is inserted, the *KNX metering gateway* creates a file named WEBSTAT.TXT after a restart. This file contains the current values of the MAC address, the IP address, the Subnet mask and the Standard gateway.

For entering of a static IP-address, additionally the parameters *IP address*, *Subnet mask* and *Standard gateway* are displayed.

Note: If a static IP-address is used, after copying of a gateway the parameter *IP address* must be adapted in the ETS to make the IP addresses unambiguous.

In commissioning, the Web-server allows, among other things, a better assignment of the values displayed, and during operation it gives a better survey of the current consumption values.

If an access on the Web-server is not desired, the Web-server can also be deactivated after successful commissioning.

When the website is called up, the Web-server uses the setting of the parameter *Language of website* for the first time. On demand, this setting can be changed in the Web-browser. This setting has no influence on the names of the datasets recorded in the further parameters.

To protect against unauthorised access, a password for the website can be entered. The password must not exceed 16 characters and can be a combination of figures, small letters from a to z, capital letters from A to Z, blanks and the special characters ! \$ % / \ () ? = + - * ~ # _ . : , ; | { } [] @ ^.

4.3.2 Aquisition of measuring values

4.3.2.1 Activation

Meter S0 1	<input checked="" type="radio"/> Not activated	<input type="radio"/> Activated
Meter S0 2	<input checked="" type="radio"/> Not activated	<input type="radio"/> Activated
Meter D0	<input checked="" type="radio"/> Not activated	<input type="radio"/> Activated
M-Bus	<input type="text" value="Not activated"/>	

Fig. 4-5: Parameters Activation of Interfaces

Depending on the meters to be used, the individual interfaces S0, D0, M-Bus and wM-Bus can be activated. Afterwards, further parameters and communication objects are displayed.

4.3.2.2 S0

Meter name (" & ' < > cannot be used!)	<input type="text" value="S0 1"/>
Pulse value factor	<input type="text" value="1000"/>
Pulse value unit	<input type="text" value="Pulses / kWh"/>
Timeout for idling detection	<input type="text" value="90"/> s
Maximum pulse length	<input type="text" value="1000"/> ms
Dataset for historical data	<input type="radio"/> No dataset <input checked="" type="radio"/> Dataset 1
Interval for historical data	
Hour	<input checked="" type="radio"/> Not activated <input type="radio"/> Activated
Day	<input checked="" type="radio"/> Not activated <input type="radio"/> Activated
Week	<input checked="" type="radio"/> Not activated <input type="radio"/> Activated
Month	<input checked="" type="radio"/> Not activated <input type="radio"/> Activated

Fig. 4-6: Parameters S0

For easy identification in the website and in the parameter structure, each meter can be provided with an unambiguous *Meter name*.

In contrast to D0 and M-Bus, the S0 interface transmits no absolute values but impulses, each corresponding to a defined value. From the number of impulses the *KNX metering gateway* can calculate the energy and the volume, and from the interval it can calculate the capacity or the volume current.

For this calculation, the two parameters *Pulse value factor* and *Pulse value unit* must be set in a way to match the indications of the meter.

The S0-interface can evaluate impulses with a length of 25 ms up to 6500 ms. The parameter *Maximum pulse length* determines from which point the *KNX metering gateway* detects a short circuit of the S0 interface. In this case, the communication object *S0 short circuit* can send a telegram with the value „1“.

With each new impulse a new capacity value is calculated from the time run up and the pulse significance. If the set *Timeout for idling detection* is overshoot, the capacity is set to value 0.

Further to the instantaneous values, for each meter, the *KNX metering gateway* can memorise the values of a dataset for consumption values at certain times (full hour, day, week (Mon – Sun), month). For these *historical data* own communication objects are displayed.

Dataset name (" & ' < > cannot be used!)	<input type="text" value="S0 1.1"/>
Activation of dataset	<input type="radio"/> Not activated <input checked="" type="radio"/> Activated
Datapoint type	<input type="text" value="13.010, DPT_ActiveEnergy, 4 Byte"/>
Factor	<input type="text" value="1"/>
Offset	<input type="text" value="0"/>
Transmission behaviour	<input type="text" value="Transmit cyclically"/>
Apply default meter level value	<input checked="" type="radio"/> Do not apply default meter level value <input type="radio"/> Apply default meter level value
Save meter level on voltage failure	<input type="radio"/> No <input checked="" type="radio"/> Yes

Fig. 4-7: Parameters S0 dataset

For meters with S0 interface two datasets are available. The first dataset contains the values for energy and volume calculated from the number of impulses. The second dataset contains the values for capacity or volume current calculated from the time interval.

For both datasets unambiguous *dataset names* can be entered which are then used in the parameter structure and in the website.

Both datasets can be activated independent of one another.

Depending on the meter type, suitable *Datapoint types* can be chosen for the communication objects. The parameters *Factor* and *Offset* allow an adaptation to the unit of the *Datapoint type*.

In basic setting, the *KNX metering gateway* sends all datasets in a stipulated transmission cycle. On demand, for each individual dataset it can be set that its value is sent in case of a defined modification or that it is not sent automatically. In this case the values can be read out via KNX if the reading flag is set.

To make sure that during commissioning of the *KNX metering gateway* the value of Dataset 1 corresponds to the current value of

the meter, the *Default meter level value* can be set which is considered only after download of the parameters.

In case of a failure of supply voltage, the *KNX metering gateway* can save the last calculated meter reading. In case of longer failures of the supply voltage of the gateway, there may nevertheless be deviations to the measuring values of the meter, since during this time the gateway cannot evaluate the impulses of the S0 interface.

4.3.2.3 D0

Meter name (" & ' < > cannot be used!)	<input type="text" value="D0"/>
Protocol selection	<input type="text" value="Mode C"/>
Number of active datasets	<input type="text" value="1"/>
The dataset for historical data must be within the range of the active datasets	
Dataset for historical data	<input type="text" value="Dataset 1"/>
Interval for historical data	
Hour	<input checked="" type="radio"/> Not activated <input type="radio"/> Activated
Day	<input checked="" type="radio"/> Not activated <input type="radio"/> Activated
Week	<input checked="" type="radio"/> Not activated <input type="radio"/> Activated
Month	<input checked="" type="radio"/> Not activated <input type="radio"/> Activated

Fig. 4-8: Parameters D0

For easy identification in the website and in the parameter structure, each meter can be provided with an unambiguous *Meter name*.

Depending on the meter used, the parameter *Protocol selection* must be set.

Via the D0 interface, meters can provide different datasets. The datasets may contain both standardised and manufacturer-specific values. Depending on the parameter *Number of datasets* additional parameters and communication objects are provided. The parameter *Number of datasets* must be set to the number of the last dataset used.

Further to the instantaneous values, for each meter, the *KNX metering gateway* can memorise the values of a dataset for consumption values at certain times (full hour, day, week (Mon – Sun), month). For these *historical data* own communication objects are displayed.

Dataset name (" & ' < > cannot be used!)	<input type="text" value="D0.1"/>
Activation of dataset	<input type="radio"/> Not activated <input checked="" type="radio"/> Activated
Datapoint type	<input type="text" value="13.010, DPT_ActiveEnergy, 4 Byte"/>
Factor	<input type="text" value="1"/>
Offset	<input type="text" value="0"/>
Transmission behaviour	<input type="text" value="Transmit cyclically"/>

Fig. 4-9: Parameters D0 dataset

For datasets set above, unambiguous *Dataset names* can be entered which are then used in the parameter structure and in the website.

The datasets can be activated independent of one another. That way, for instance, manufacturer-specific data sets can be hidden.

Depending on the meter type, suitable *Datapoint types* can be chosen for the communication objects. The parameters *Factor* and *Offset* allow an adaptation to the unit of the *Data point type*.

In basic setting, the *KNX metering gateway* sends all datasets in a stipulated transmission cycle. On demand, for each individual dataset it can be set that its value is sent in case of a defined modification or that it is not sent automatically. In this case the values can be read out via KNX if the reading flag is set.

4.3.2.4 M-Bus and wM-Bus

Number of meters	<input type="text" value="1"/>
Communication mode wMbus	<input type="radio"/> S1 <input checked="" type="radio"/> T1

Fig. 4-10: Parameters M-Bus

In the use of M-Bus- or wM-Bus meters, the parameter *Number of meters* is set first. Depending on this first parameter, further parameters and communication objects are displayed.

The use of wM-Bus meters is possible either with the communication mode S1 or T1. The information which communication mode is supported by a meter can be obtained from the manufacturer.

Meter name (" & ' < > cannot be used!)	<input type="text" value="M-Bus / wM-Bus 1"/>
Meter type	<input checked="" type="radio"/> M-Bus meter <input type="radio"/> wM-Bus meter
Secondary address	<input type="text" value="00000000"/>
Number of active datasets	<input type="text" value="1"/>
The dataset for historical data must be within the range of the active datasets	
Dataset for historical data	<input type="text" value="Dataset 1"/>
Interval for historical data	
Hour	<input checked="" type="radio"/> Not activated <input type="radio"/> Activated
Day	<input checked="" type="radio"/> Not activated <input type="radio"/> Activated
Week	<input checked="" type="radio"/> Not activated <input type="radio"/> Activated
Month	<input checked="" type="radio"/> Not activated <input type="radio"/> Activated

Fig. 4-11: Parameters wM-Bus meter

For easy identification in the website and in the parameter structure, each meter can be provided with an unambiguous *Meter name*.

The parameter *Meter type* determines whether the parameter *AES-key*, which is used only for wM-Bus meters, is displayed. The further parameters are identical for M-Bus and wM-Bus meters.

In case of wired M-Bus meters the *KNX metering gateway* can address the meters actively. In case of wireless wM-Bus meters the gateway waits for the meters to send the measuring values autonomously.

Via M-Bus and wM-Bus the meters can provide different datasets. The datasets may contain standardised or manufacturer-specific values. Depending on the parameter *Number of datasets* additional parameters and communication objects are provided. It must be set to the number of the last dataset used.

Further to the instantaneous value, for each meter, the *KNX metering gateway* can memorise the values of a dataset for consumption values at certain times (full hour, day, week (Mon – Sun), month). For these *historical data* own communication objects are displayed.

Dataset name (" & ' < > cannot be used!)	<input type="text" value="M-Bus / wM-Bus 1.1"/>
Receive dataset	<input type="radio"/> Not activated <input checked="" type="radio"/> Activated
Datapoint type	<input type="text" value="13.010, DPT_ActiveEnergy, 4 Byte"/>
Factor	<input type="text" value="1"/>
Offset	<input type="text" value="0"/>
Transmission behaviour	<input type="text" value="Transmit cyclically"/>

Fig. 4-12: Parameters wM-Bus dataset

For the datasets set above, unambiguous *Dataset names* can be entered which are then used in the parameter structure and in the website.

The datasets can be activated independent of one another. That way, for instance, manufacturer-specific datasets can be hidden.

Depending on the meter type, suitable *Datapoint types* can be chosen for the communication objects. The parameters *Factor* and *Offset* allow an adaptation to the unit of the *Datapoint type*.

In basic setting the *KNX metering gateway* sends all datasets in a stipulated transmission cycle. On demand, for each individual dataset it can be set that its value is sent in case of a defined modification or that it is not sent automatically. In this case the values can be read out via KNX if the reading flag is set.

4.4 Web-server

For use of the Web-server, the suitable parameters for the network interface must be set in the ETS and the Web-server must be activated.



Fig. 4-13: Web-Server Login

Afterwards, by entering the IP-address in the Web-browser the login page of the *KNX Metering gateway* can be loaded. Firefox, Chrome and Safari are supported.

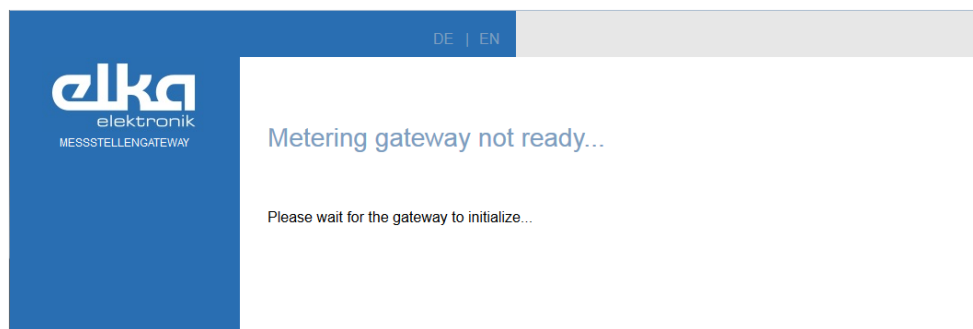

Fig. 4-14: Web-Server during initialisation

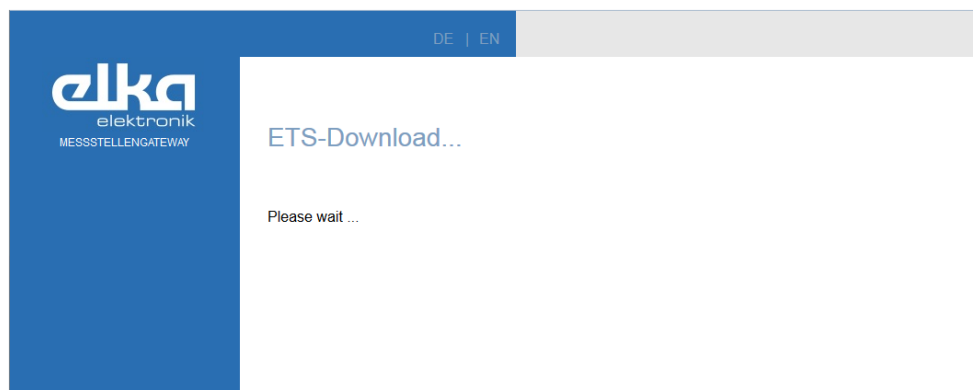
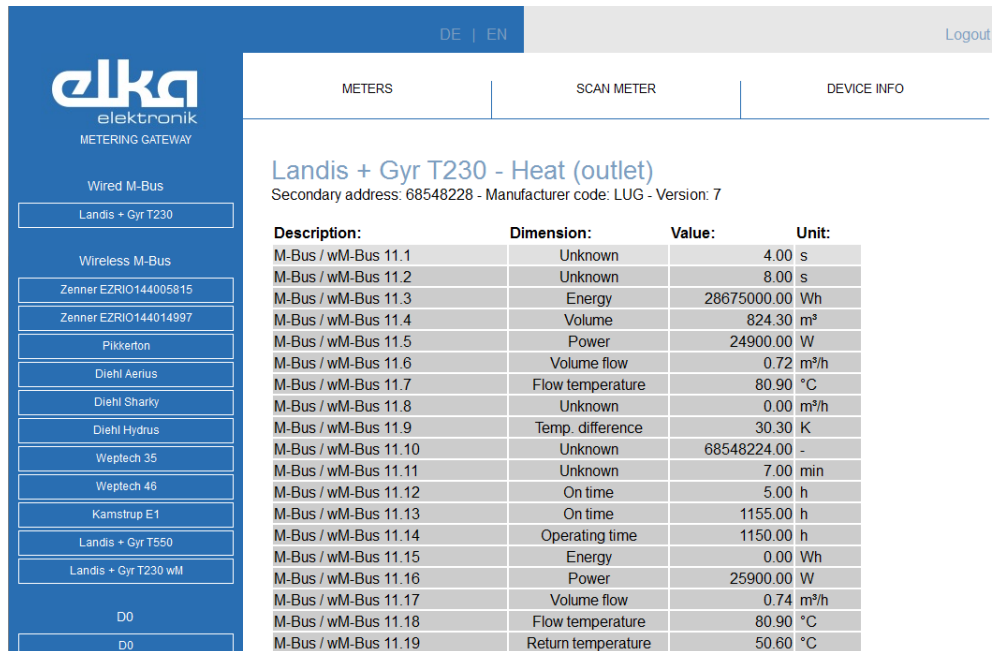

Fig. 4-15: Web-Server after ETS download

During a restart of the *KNX Metering gateway* or after commissioning, instead of the login page a corresponding note may be displayed.

The internal data synchronisation after commissioning and the search for connected meters may take some minutes. During this process, the LED *Power/Error* flashes yellow. When it shines green again, initialisation is completed.

4.4.1 Meter



The screenshot shows the web interface of the elka Metering Gateway. On the left, there is a sidebar with a list of meters under 'Wired M-Bus' and 'Wireless M-Bus'. The selected meter is 'Landis + Gyr T230'. The main content area displays the meter's name, secondary address (68548228), manufacturer code (LUG), and version (7). Below this, a table lists various datasets with their descriptions, dimensions, values, and units.

Description:	Dimension:	Value:	Unit:
M-Bus / wM-Bus 11.1	Unknown	4.00	s
M-Bus / wM-Bus 11.2	Unknown	8.00	s
M-Bus / wM-Bus 11.3	Energy	28675000.00	Wh
M-Bus / wM-Bus 11.4	Volume	824.30	m³
M-Bus / wM-Bus 11.5	Power	24900.00	W
M-Bus / wM-Bus 11.6	Volume flow	0.72	m³/h
M-Bus / wM-Bus 11.7	Flow temperature	80.90	°C
M-Bus / wM-Bus 11.8	Unknown	0.00	m³/h
M-Bus / wM-Bus 11.9	Temp. difference	30.30	K
M-Bus / wM-Bus 11.10	Unknown	68548224.00	-
M-Bus / wM-Bus 11.11	Unknown	7.00	min
M-Bus / wM-Bus 11.12	On time	5.00	h
M-Bus / wM-Bus 11.13	On time	1155.00	h
M-Bus / wM-Bus 11.14	Operating time	1150.00	h
M-Bus / wM-Bus 11.15	Energy	0.00	Wh
M-Bus / wM-Bus 11.16	Power	25900.00	W
M-Bus / wM-Bus 11.17	Volume flow	0.74	m³/h
M-Bus / wM-Bus 11.18	Flow temperature	80.90	°C
M-Bus / wM-Bus 11.19	Return temperature	50.60	°C

Fig. 4-16: Web-Server Display of readings

On the page *Meter*, on the left hand side, the list of meters projected in the ETS is shown. Here a meter can be selected. On the right hand side, details on this meter and on its datasets are displayed. The scope of details displayed depends on the type of meter and the projecting. In case of S0 and D0 meters, placeholders may be displayed instead of secondary address, manufacturer code and version.

The datasets of the selected meter are then displayed on the table. Here also the datasets are listed which are not activated in the ETS, up to the configured number of datasets.

The values in the column *Description* are the parameterised *Dataset names*. With D0-, M-Bus and wM-Bus, the values in the columns *Size*, *Value* and *Unit* are taken over from the data transferred by the meters. In case of S0 meters, the entries in the columns *Size* and *Unit* are taken over from the parameterisation and the entries of column *Value* are calculated internally in the *KNX Metering gateway* from the impulses registered.

4.4.2 Meter search

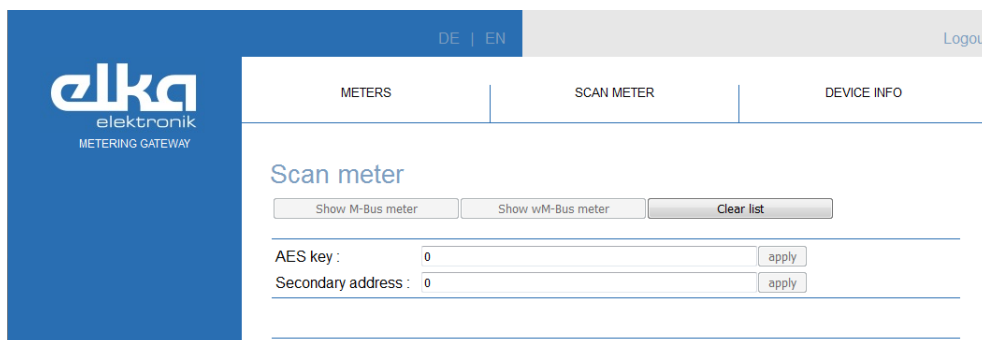

Fig. 4-17: Web-Server Meter search

Especially in commissioning of new meter types questions with regard to the existing datasets may arise. Here the page *Meter search* shows details, independent of the product documentation of the meter.

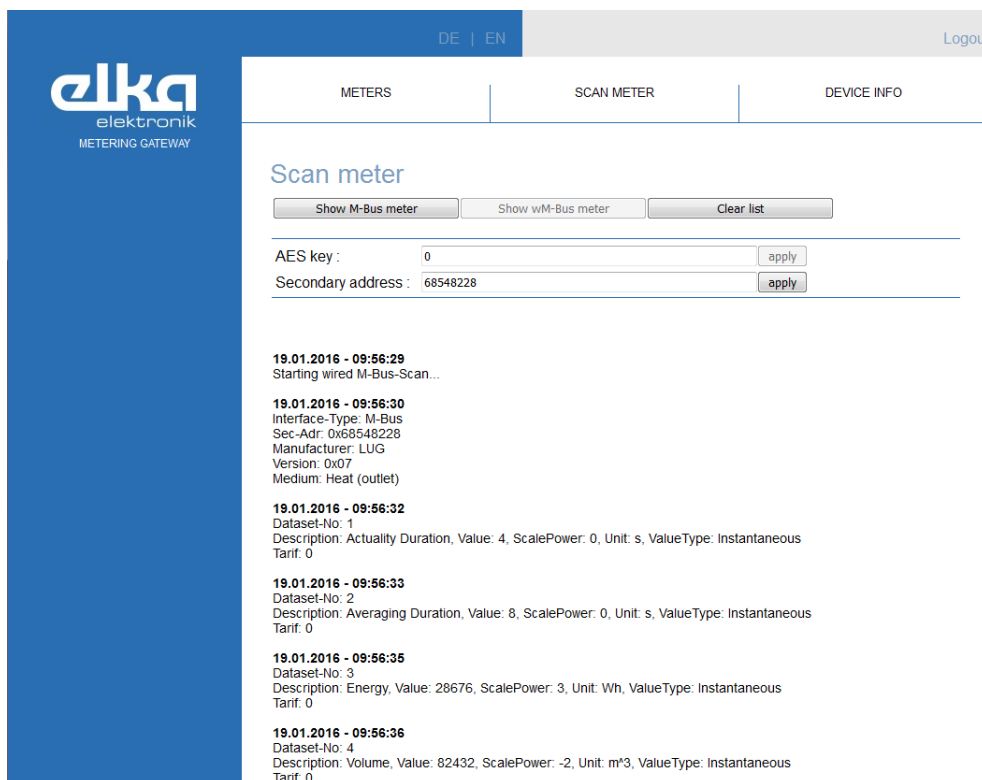

Fig. 4-18: Web-Server Display of an M-Bus meter

To display the details of an M-Bus meter, the *Secondary address* must be entered. With a click on the button *Apply* the button *Show M-Bus meter* is released.

Afterwards, the data the *KNX Metering gateway* receives from the meter are displayed.

In the first part, information on the meter are listed.

Interface type:	media type M-Bus or wM-Bus
Sec-Adr:	secondary address of the meter
Manufacturer:	short form of the manufacturer name
Version:	software version of the meter
Medium:	the medium registered by the meter (current, water, ...)
RSSI:	only with wM-Bus, the strength of the signal received.

In the second part, information on the individual datasets are listed:

Dataset-No:	number of the dataset
Description:	the identified size
Value:	the identified measuring value under consideration of the following exponent to the basis 10
Scale-Power:	the exponent to the basis 10 for scaling of the measuring value
Unit:	unit of the identified size
ValueType:	description of the measuring value as momentary, minimum or maximum value
Tariff:	in case of multi-tariff meters, the description of the tariff level

The complete measuring value is calculated by the formula below:

$$\text{Measuring value} = \text{Value} * 10^{\text{Scale-Power}} * \text{Unit}$$

Examples:

Value:	858
Scale Power:	2
Unit:	Wh

$$\begin{aligned} \text{Measuring value} &= 858 * 10^2 \text{ Wh} \\ &= 858 * 100 \text{ Wh} \\ &= 85800 \text{ Wh} \end{aligned}$$

Value:	10982960
Scale Power:	-3
Unit:	m ³

$$\begin{aligned} \text{Measuring value} &= 10982960 * 10^{-3} \text{ m}^3 \\ &= 10982960 * 0.001 \text{ m}^3 \\ &= 10982.960 \text{ m}^3 \end{aligned}$$

4.4.3 Device information

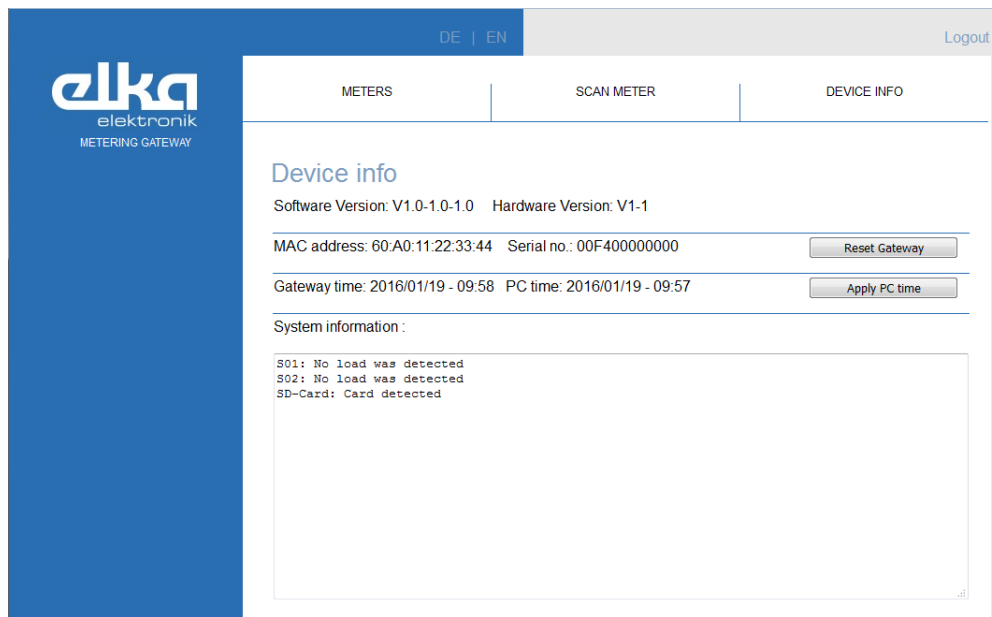

Fig. 4-19: Web-Server Display of device information

The page *Device information* gives some basic information on the *KNX Metering gateway*.

With the button *Reset Gateway* you can restart the *KNX Metering gateway* if, for instance, the values of newly connected M-Bus or wM-Bus meters are not displayed on the page Meter search. The re-start includes a scan of the M-Bus and wM-Bus meters.

In the parameters, the internal clock of the *KNX metering gateway* can be synchronised via an NTP server or via KNX communication objects. In case both references are not available in the system installed, a manual synchronisation can be effected via the button *Apply PC-time*.

5 Appendix

5.1 M-Bus

M-Bus is a system for transmission of measuring values and is used, for instance, for current, heat, water and gas meters.

5.1.1 Structure

Within an M-Bus segment different meters can be connected to a master as slave.

The M-Bus interfaces of the slave devices are supplied by the master. Depending on the field of use, they can also have an external supply and/or a battery. The maximum possible number of slaves depends on the structure of the master.

5.1.2 Addressing

M-Bus meters support two different addressing modes. The primary address, for instance, can be allocated on site by a separate PC program. The secondary address is an unambiguous address assigned by the manufacturer of the meter. It often corresponds to the serial number of the meter.

5.1.3 Installation

Installation may be effected e.g. with simple cables of type JY-(St)-Y 2x2x0.8. The two-core bus lead can be laid in tree structure. It is not poled.

5.1.4 Data transmission

During an M-Bus scan, the M-Bus master can detect the installed M-Bus slaves. After identification of the slaves, the master can determine the datasets available.

The M-Bus meters can have a large number of different datasets. For some datasets there are standardised formats like energy in Wh or in kWh. There may also be manufacturer-specific datasets. The order of the datasets like, for instance, the energy received at different tariffs is not standardised. In case of doubt, the transferred values can be compared with the values displayed at the meter or with the documentation of the meter manufacturer.

During operation, the *KNX Metering gateway* can read out the specific values of the M-Bus meters.

5.2 Wireless M-Bus

With wireless-M-Bus there is the possibility of wireless transmission of the readings. There are some differences to the wired M-Bus, for instance to guarantee safety of the data transmitted and the service life of battery-powered meters.

5.2.1 Addressing

Wireless-M-Bus meters use the same addressing modes as the wired M-Bus meters.

5.2.2 Installation

During installation of the wM-Bus meters please make sure that the transmission quality is not impaired by sources of interference like metal surfaces, microwave ovens, Hi-fi and TV systems, ballasts or transformers.

The range of the radio transmission is limited, among others, by the structure of walls and ceilings.

5.2.3 Data transmission

Wireless-M-Bus meters can use different transmission modes. In the operation modes S1 and T1 the meters operate unidirectional as pure transmitters. They differ in the frequency of the transmission processes and in the length of the individual messages. Meters with the operation mode S1 are designed for stationary receivers. They have comparatively long transmission cycles which may be hours. Meters with the operation mode T1 are designed for mobile receivers. They have comparatively short transmission cycles.

To safeguard the transmitted data, all measuring values are encrypted. Only by means of the correct AES-key can the values be decrypted and evaluated. Questions on the AES-key must be clarified with the manufacturer of the meter or with the operator of the measuring point.

5.3 S0

By the S0 interface a meter with impulse output can be connected to a device with impulse input.

5.3.1 Devices

The device with impulse input generates a direct current and evaluates the current flow.

The impulse output must be safely separated from other voltages in the meter.

5.3.2 Installation

Installation is effected by means of a two-core cable. Maximum cable length is 100 m.

5.3.3 Data transmission

With the S0 interface, the data are transmitted as individual impulses, each corresponding to a defined value. The summed-up number of impulses corresponds to the current consumption. From the interval between two impulses the current capacity can be calculated.

The minimum admissible impulse length of the meters is 30 ms.

5.4 D0

The D0 interface is a bi-directional serial interface between a meter and a reader.

5.4.1 Devices

The meters have an interface with an infrared transmitter and an infrared receiver. The IR interface is embraced by a steel plate. The reader also has got an IR interface which is installed in a receiver with a ring-type magnet.

The interface can be deactivated by the manufacturer or by the operator of the measuring point or be protected by a password.

5.4.2 Installation

Installation is effected by plugging the optical reading head on the infrared interface of the meter.

5.4.3 Data transmission

Different operation modes for transmission are defined. They differ in transmission speed and in the question whether the reader demands the values from the meter or whether the meter sends them.

Number and order of the datasets are not determined. The datasets may use standardised or manufacturer-specific formats.

5.5 KNX

KNX is a distributed bus system for building automation.

To guarantee a co-operation among devices of different manufacturers, for different basic functions the sizes of the communication objects and their functions are standardised by the KNX Association.

Projection of all functions in a building and commissioning of the devices are effected by PC.

5.5.1 Structure

In a bus segment, up to 64 devices can be installed, all being able to receive and to transmit. Each bus segment has its own power supply.

In case of larger installations, several electrically divided bus segments are linked logically via line or area couplers. The line and area couplers filter the telegrams and pass on only those telegrams needed in the relevant bus segment.

5.5.2 Installation

For installation two cores of a four-core cable of type JY(St)Y 2x2x0.8 are used. The cable is laid in tree structure. Regarding the cable length in a bus segment several criteria have to be observed: The overall length with all branches must not exceed 1000 m. The distance between the power supply and a device must not exceed 350 m. The distance between two members must not exceed 700 m. The cable is poled.

5.5.3 KNX devices

In the installation, each device has an unambiguous physical address which is also used for commissioning.

For determination of the function, each device has got logical communication objects. Number and size of these communication objects depend directly on the function of each device. The communication objects are linked with one another via group addresses. All devices with identical group addresses work together.

5.5.4 Data transmission

Data transmission is effected with 9600 bit/s. The length of each telegram depends on the size of the communication objects.

In most cases a KNX device sends a telegram with the new value of the communication object in case of a certain event, for instance the modification of a temperature value or pressing of a key. In some cases devices can be set in such a way to send new telegrams regularly without modification of a value.

5.6 Legal notices

The *KNX-Metering gateway* uses FreeRTOS Version 8.1.2. FreeRTOS is subject to a modified GNU General Public License. The source code of FreeRTOS is freely available. Further information under www.freertos.org or by e-mail to support@elka.de.