

Compact USB Interface between PC and KNX bus

KNX USB Interface 312.1

Operation and installation manual



(Art. # 5501)

WEINZIERL ENGINEERING GmbH
Achatz 3-4
84508 Burgkirchen an der Alz
GERMANY

Tel.: +49 8677 / 916 36 – 0
E-Mail: info@weinzierl.de
Web: www.weinzierl.de

Content

1	Application	3
2	KNX Security	3
3	Installation and connection	4
3.1	KNX programming mode.....	4
3.2	Status display.....	4
3.3	USB suspend	5
4	Factory default settings.....	5
5	Wiring scheme	6
6	Interface settings in the ETS	6
6.1	ETS 5.....	6
6.2	ETS 6.....	7
7	ETS database	8
7.1	Description.....	8
7.2	USB channel.....	9
8	Bus monitor mode	9
9	KNX Long Frames.....	9
10	Notes for developers	11

1 Application

The KNX USB Interface 312.1 is a data interface between a PC or laptop and the KNX installation bus.

The device can be used as a programming interface for ETS® Software and supports KNX Long Frames. Long telegrams enable a faster download to devices that support these telegrams, and it is necessary for KNX Security.

The LEDs on the device indicate the operating status and communication errors on the bus. The USB connector (USB C) is galvanic isolated from the KNX bus.

2 KNX Security

The KNX standard was extended by KNX Security to protect KNX installations from unauthorized access. KNX Security reliably prevents the monitoring of communication as well as the manipulation of the system.

KNX Data Security describes encryption at the telegram level. This means that the telegrams are encrypted on the twisted pair bus.

The KNX USB interface supports the so-called KNX long frames (long telegrams) and is therefore compatible with KNX security telegrams.

In the KNX specification, USB interfaces are regarded as local devices that do not require additional protection. Access to the USB interface is therefore the same as access to the TP bus. This means that KNX USB interfaces should not be publicly accessible.

3 Installation and connection

The KNX USB Interface 312.1 is designed for installation on a DIN rail with a width of 1 unit (18 mm). It features the following controls and displays:

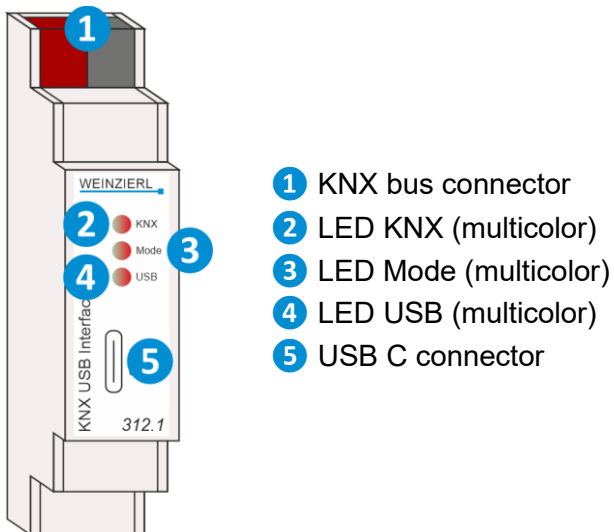

The KNX USB Interface 312.1 is powered by USB. An external power supply is not necessary.



The device is not working without USB connection.

3.1 KNX programming mode

The individual address of the interface can be set locally via the ETS. Therefore no programming button or LED is available on this device.

If programming mode is activated via the BAOS protocol, this is indicated by LED Mode **3** lighting up red.

3.2 Status display

The LED KNX **2** lights up green if the device is successfully connected to the KNX bus. This LED indicates telegram traffic on the KNX bus by flickering.

KNX communication failures (e.g. repetitions of telegrams or telegram fragments) are indicated by a short change of the LED color to red.

Overview of the different indications of the LED KNX **2**:

LED Status	Meaning
LED lights green	KNX bus voltage available.
LED flickers green	Telegram traffic on the KNX bus
LED shortly red	Communication failures on the KNX bus

The LED Mode **3** lights up green when the device is connected to USB. If the interface is set to bus monitor mode, this LED lights up orange.

Overview of the different indications of the LED Mode **3**:

LED Status	Meaning
LED lights green	USB active
LED lights red	Programming mode is activated via BAOS protocol
LED lights orange	Interface is set to bus monitor mode

The LED USB **4** lights up green if the device is connected to USB. This LED indicates telegram traffic on the USB by flickering.

USB communication failures are indicated by a short change of the LED color to red.

Overview of the different indications of the LED USB **4**:

LED Status	Meaning
LED lights green	USB active
LED flickers green	Telegram traffic on USB
LED shortly red	Communication failures on USB

3.3 USB suspend

If the PC or Laptop switches to suspend mode also connected USB devices will be suspended to save energy. Computers running MS Windows® 8.1 or higher may set unused peripherals to standby even during normal operation. In suspend mode all LEDs of the KNX USB interface are off.

4 Factory default settings

The following configuration is set by factory default:

Individual address: 15.15.255

5 Wiring scheme

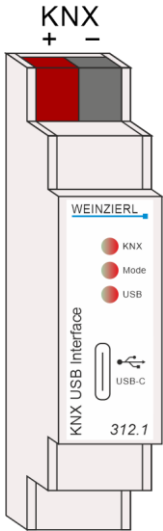

6 Interface settings in the ETS

6.1 ETS 5

In the ETS 5, interfaces can be selected and configured via the ETS menu “Bus – Interfaces”. All available connections are listed under “Discovered Interfaces”. After clicking on the desired connection, connection specific information and options appear on the right side of the ETS window. The selected connection can be selected as the “Current Interface” via the “Select” button.

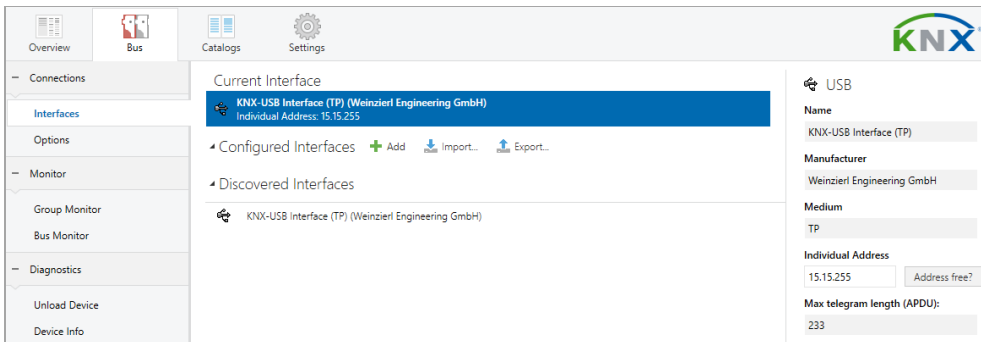

6.2 ETS 6

In the ETS 6, interfaces can be selected and configured in the ETS project via the “Interface” button. All available connections are listed here.

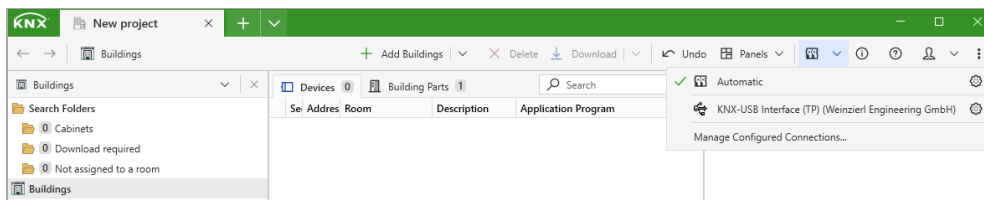

By clicking on a connection, this is selected as the desired interface.

By clicking the gear next to the desired connection, the connection specific information and options appear.

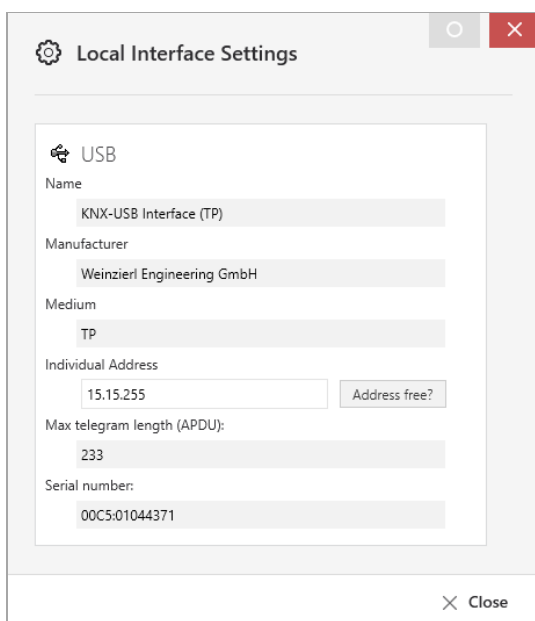

7 ETS database

The ETS5 database (for ETS 5.7 or newer) can be downloaded from the product website of the KNX USB Interface 312.1 (www.weinzierl.de) or from the ETS online catalogue.

The ETS entry is not required to use the KNX USB Interface as programming interface. It is just a placeholder to show all installed devices in the topology.

7.1 Description

1.1.1 KNX USB Interface 312.1 > Device description

Device description

KNX USB Interface 312.1
With KNX Long Frames, USB-C

The KNX USB Interface 312.1 is a data interface between a PC or laptop and the KNX installation bus.

The device can be used as a programming interface for ETS® Software and supports KNX Long Frames.

Long telegrams enable a faster download to devices that support these telegrams, and it is necessary for KNX Security.

The LEDs on the device indicate the operating status and communication errors on the bus. The USB connector (USB C) is galvanic isolated from the KNX bus.

Wiring scheme:





Please consult device data sheet and manual for further information.

Contact:

WEINZIERL ENGINEERING GmbH
 Achatz 3-4
 84508 Burgkirchen an der Alz
 GERMANY
www.weinzierl.de
info@weinzierl.de

This page shows the device description and the corresponding connection diagram.

7.2 USB channel

Group addresses can be dragged onto the USB channel of the interface. As a result, these group addresses are included in the filter tables of the corresponding couplers.

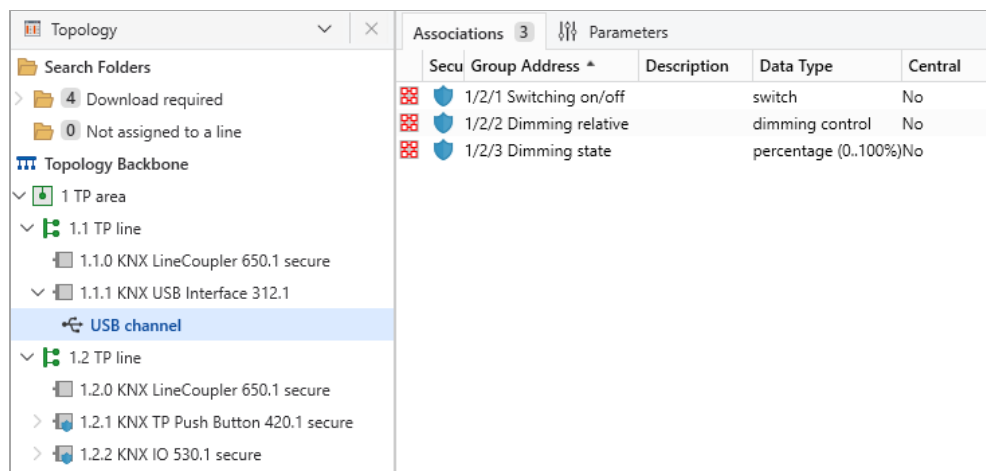

This is required if the interface shall receive the group communication of another line, e.g. for a visualization.

8 Bus monitor mode

The KNX USB interface supports the bus monitor mode and can be used with ETS. In bus monitor mode all traffic on the KNX bus is shown including ACK, NACK and BUSY characters.

Interfaces in bus monitor mode are completely passively on the bus and therefore cannot be used simultaneously for other operations like download. To monitor an ETS download within the same ETS the group monitor can be used. The group monitor uses the KNX USB interface in normal operation mode (data link layer) and can be used in parallel to other bus operations. In the group monitor also sending of telegrams is possible.

Note that in group monitor mode individual addressed telegrams which do not address the KNX USB interface cannot be received.

9 KNX Long Frames

Standard KNX telegrams are limited to an APDU length of 15. The APDU length is the number of bytes in the payload. A group telegram holding a 14 byte string (KNX data point type 16) results in an APDU length of 15.

To increase the efficiency of KNX communication mainly for the download an extended format has been defined. It can be used to send longer telegrams on the bus. To use this feature it must be supported by

- the tool (ETS)
- the bus interface (USB)
- all couplers in between
- the addressed device

ETS starting with version 5 is able to detect automatically whether long frames can be used and optimizes the download accordingly.

The max APDU length of the KNX USB interface and which is used by ETS is 233. This length has been specified as requirement for new KNX system devices. An APDU length of 233 results in total length of a KNX telegram on twisted pair of 242 bytes and occupies the bus for about 340 ms.



The download is much faster if the USB interface is installed in the same line as the target device. With each line coupler in-between the download time grows.

10 Notes for developers

The KNX USB communication is based on HID and cEMI telegram coding according to the KNX specification. To integrate the KNX USB interface in applications running on Windows or Linux the cross-platform SDK kDriveExpress is available from Weinzierl.

In addition to the telegram interface via cEMI, the KNX USB Interface 312.1 includes a complete KNX Stack with communication objects and BAOS protocol V2. Thus, the device offers the possibility to extend devices with USB connection (e.g. boards with embedded Linux) to full KNX devices, which can even be programmed with the ETS.

For more information about this solution and available SDKs please contact WEINZIERL.



WARNING

- The device must be mounted and commissioned by an authorized electrician.
- The prevailing safety rules must be heeded.
- The device must not be opened.
- For planning and construction of electric installations, the relevant guidelines, regulations and standards of the respective country are to be considered.



Product database for ETS 5/6

www.weinzierl.de/en/products/312.1/ets6

Data sheet

www.weinzierl.de/en/products/312.1/datasheet

CE Declaration

www.weinzierl.de/en/products/312.1/ce-declaration

WEINZIERL ENGINEERING GmbH

Achatz 3-4
84508 Burgkirchen an der Alz
GERMANY

Tel.: +49 8677 / 916 36 – 0

E-Mail: info@weinzierl.de

Web: www.weinzierl.de

2025-06-23