

KNX 1-10V CONTROL UNIT 4 GANG

Safety instructions



Electrical devices may only be mounted and connected by electrically skilled persons.

Serious injuries, fire or property damage possible. Please read and follow manual fully.

Danger of electric shock. Device is not suitable for disconnection from supply voltage.

Danger of electric shock. The 1...10 V control voltage is a functional extra-low voltage (FELV), and can be connected to mains potential. On installing, ensure safe separation to SELV/PELV systems. In order to disconnect the connected luminaires, disconnect both the mains voltage and control voltage circuits.

These instructions are an integral part of the product, and must remain with the end customer.

Device components

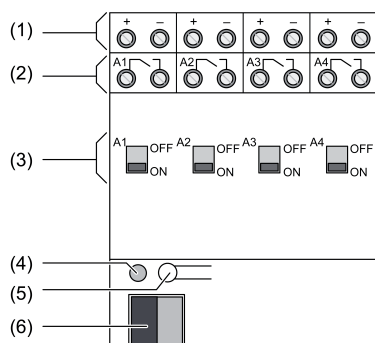

Figure 1

- (1) Connection for control inputs
- (2) Connection for switching outputs
- (3) Slide switch/Status indication
- (4) Programming LED
- (5) Programming button
- (6) KNX connection

Function

System information

This device is a product of the KNX system and complies with the KNX directives. Detailed technical knowledge obtained in KNX training courses is a prerequisite to proper understanding.

The function of this device depends upon the software. Detailed information on loadable software and attainable functionality as well as the software itself can be obtained from the manufacturer's product database. Planning, installation and commissioning of the device are carried out with the aid of KNX-certified software. The latest versions of product database and the technical descriptions are available on our website.

Intended use

- Switching and brightness setting for lamps with operating devices with 1-10-V interface
- Switching of electrical consumers
- Mounting on DIN rail according to EN 60715 in distribution boxes

Product characteristics

- Manual switching of the relays is independent of the bus.
- Switching of capacitive loads and the resulting high switch-on currents
- Flexible assignment of control inputs to switching outputs, e.g. to control RGBW lamps
- Operation of the switching outputs as a switching actuator
- Connection of various external conductors
- No additional power supply necessary
- Feedback of switching state and brightness value
- Switch position display
- Burn-in function for fluorescent lamps
- Switch-on and dimming behaviour can be set
- Time functions: switch-on delay, switch-off delay, staircase lighting timer with run-on time
- Integration into light scenes
- Operating hours counter

Operation

Switching relay contacts manually

The status of the relay is reflected by the slide switches (3) on the front of the device.(figure 1). At the same time they can be used for manual operation of the relay outputs using a suitable tool.

- o Move slide switch to **ON** position.
Relay contact is closed, load is switched on.
- o Move slide switch to **OFF** position.
Relay contact is open, load is switched off.
- i Outputs disabled via software can still be switched manually.

Information for electrically skilled persons

Mounting and electrical connection



DANGER!

Electrical shock when live parts are touched.

Electrical shocks can be fatal.

Before carrying out work on the device or load, disengage all the corresponding circuit breakers. Cover up live parts in the working environment.

Fitting the device

Observe the temperature range. Ensure adequate cooling.

- o Mount device on DIN rail. Output terminals must be at the top.

Connecting the device

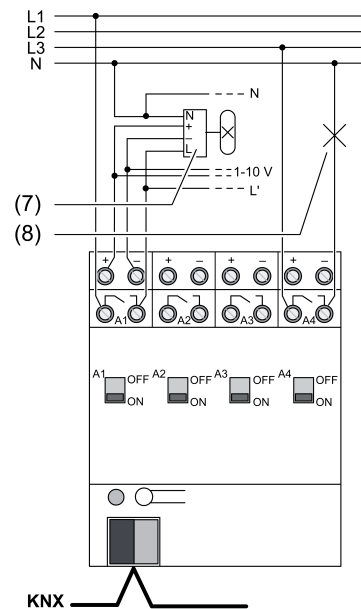

Figure 2: Connection example - Lamp operating device with 1-10 V interface

- (7) Lamp operation device with 1-10 V interface
- (8) Switched load, e.g. luminaire (switching actuator operation)

Control cable: appropriate type, cross-section and routing for the specifications for mains voltage cables. 1-10 V and mains voltages wires can be run together in a cable, e.g. NYM 5x1.5 mm².

Only use lamp operating devices that are of the same type, the same power level, and from the same manufacturer. Otherwise there may be differences in brightness between the individual lamps.

The maximum number of lamp operating devices that can be connected is a function of the sum of the control currents.

- i Electronic lamp operating devices generate high current spikes when they are switched on, that can result in sticking of the relay contacts. Note switch-on currents. In the case of loads with high switch-on current, use switch-on current limiter or separate load protection.
- o Connect the device according to the connection diagram .
- o If multiple circuit breakers supply dangerous voltages to the device or load, couple the miniature circuit breakers or label them with a warning, to ensure disconnection is guaranteed.



KNX 1-10V CONTROL UNIT 4 GANG

Art. No. WRKT5104E5NC

Operating instructions



Panasonic Life Solutions Elektrik San.ve Tic. A.Ş.
Abdurrahmangazi Mah. Ebubekir Cad. No: 44
34887 Sancaktepe / Istanbul / Turkey
T: 0(216) 564 55 55 F: 0(216) 564 55 44

HOTLINE
444 8456

Istr.panasonic.com

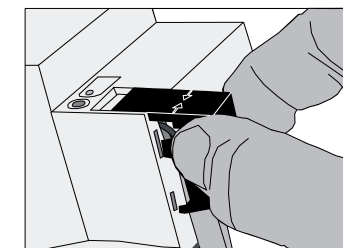

Figure 3

Installing the cover

Install the cover to protect the bus connection against hazardous voltages in the connection area.

Commissioning

Load the address and the application software

- o Switch on the bus voltage.
- o Assign physical addresses and load application software into the device.
- o Note the physical address on the device label.

Finely stranded with conductor sleeve 0.14 ... 2.5 mm²
Fitting width 72 mm / 4 modules

Warranty

The warranty follows about the specialty store in between the legal framework as provided for by law.

Technical data

KNX	TP
KNX medium	S-mode
Commissioning mode	DC 21 ... 32 V SELV
Rated voltage KNX	max. 6 mA
Current consumption KNX	max. 4 W
Power loss	
Ambient temperature	-5 ... +45 °C
Storage/transport temperature	-25 ... +70 °C
Control outputs	
Control voltage	1 ... 10 V
Control current per output	max. 100 mA
Cable length	max. 500 m (0.5 mm ²)
Switching outputs	
Contact type	μ contact
Switching voltage	AC 250 / 400 V
Switching current 230 V AC	16 A
1	
Switching current 230 V AC	10 A
3	
Switching current 400 V AC	10 A
1	
Switching current 400 V AC	6 A
3	
Fluorescent lamps	16 AX
Switching voltage DC	DC 12 ... 24 V
Switching current DC	16 A
Minimum switching current	100 mA
Switch-on current 150 μs	600 A
Switch-on current 600 μs	300 A
Ohmic load	3680 W
Capacitive load	16 A / 200 μF
Lamp loads	
Incandescent lamps	3680 W
HV halogen lamps	3680 W
LV halogen lamps with inductive transformer	2000 VA
LV halogen lamps with Tronic transformer	2500 W
Fluorescent lamps T5/T8 uncompensated	3680 W
parallel compensated	2500 W / 200 μF
twin-lamp circuit	3680 W / 200 μF
Compact fluorescent lamps uncompensated	3680 W
parallel compensated	2500 W / 200 μF
Mercury vapour lamps uncompensated	3680 W
parallel compensated	3680 W / 200 μF
Connection	
single stranded	0.5 ... 4 mm ²
Finely stranded without conductor sleeve	0.34 ... 4 mm ²