

User manual

K-BUS KNX Glass Sensor GS3_V1.1

CHTBD-06/3.2.1x (Standard)

CHTBD-06/5.2.1x (Pro)

(x=0: White; x=1: Black; x=3: Gray; x=4: Golden)

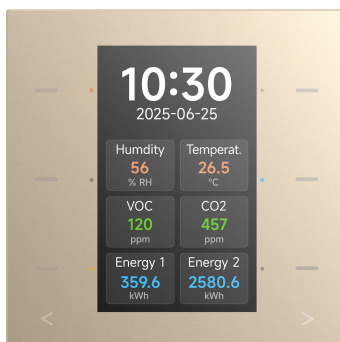
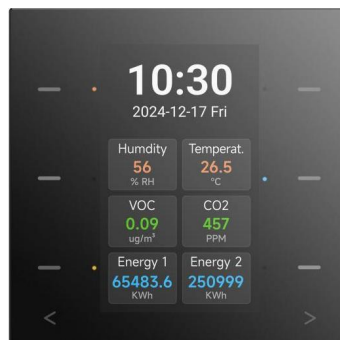
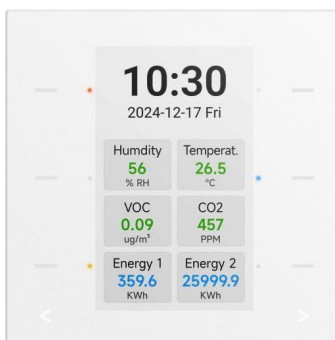

KNX/EIB Home and Building Control System

Attentions

1. Please keep devices away from strong magnetic field, high temperature, wet environment;

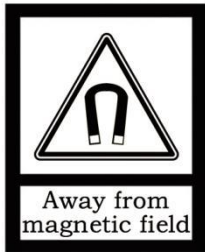

2. Do not fall the device to the ground or make them get hard impact;



3. Do not use wet cloth or volatile reagent to wipe the device;



4. Do not disassemble the devices.

Contents

Chapter 1 Introduction	1
Chapter 2 Technical characteristic	3
Chapter 3 Dimension and connection diagram	4
3.1. Dimension drawing	4
3.2. Connection diagram	4
Chapter 4 Application programming introduction	6
Chapter 5 Parameters setting description in the ETS	9
5.1. KNX secure	9
5.2. Parameter window“General”	14
5.2.1. Parameter window“General setting”	14
5.2.2. Parameter window“Brightness setting”	20
5.2.3. Parameter window“Screen saver setting”	25
5.2.4. Parameter window“Night mode setting”	30
5.2.5. Parameter window“Proximity setting”	31
5.2.6. Parameter window“Colorful strip setting”	33
5.2.7. Parameter window“Alarm setting”	37
5.2.8. Parameter window“Advance function”	40
5.3. Parameter window“Internal sensor measurement”	41
5.3.1. Parameter window“Temperature sensor”	41
5.3.2. Parameter window“Humidity sensor”	44
5.4. Parameter window“Button”	46
5.4.1. Individual button	50
5.4.1.1. Switch	50
5.4.1.2. Dimming	53
5.4.1.3. RGB switching/send value	56
5.4.1.4. RGBW switching/send value	57
5.4.1.5. Colour temperature switching/send value	58
5.4.1.6. Value sender	59
5.4.1.7. Scene control	60

5.4.1.8. Blind -----	62
5.4.1.9. Shift register -----	64
5.4.1.10. Multiple operation -----	68
5.4.1.11. Delay mode -----	70
5.4.1.12. Status display -----	72
5.4.1.13. RGB dimming -----	74
5.4.1.14. RGBW dimming -----	77
5.4.1.15. Colour temperature dimming -----	80
5.4.1.16. Colour temperature adjustment -----	83
5.4.2. Status indication of individual button -----	85
5.4.3. Rocker button -----	93
5.4.3.1. Switch -----	93
5.4.3.2. Dimming -----	97
5.4.3.3. Scene control -----	100
5.4.3.4. Blind -----	102
5.4.3.5. Setpoint adjustment -----	104
5.4.4. Status indication of rocker button -----	107
5.4.4.1. Left/Right field display -----	107
5.4.4.2. Middle field display -----	109
5.4.5. Status LED indication -----	119
5.4.6. Slap function -----	125
5.4.7. Parameter window“Customized colour” -----	128
5.5. Parameter window“Room temperature controller” -----	129
5.5.1. Parameter window“RTC x(x=1,2)” -----	130
5.5.2. Parameter window“Setpoint” -----	138
5.5.2.1. Relative -----	139
5.5.2.2. Absolute -----	144
5.5.3. Parameter window“Heating/Cooling control” -----	147
5.5.4. Parameter window“Fan auto.control” -----	157
5.6. Parameter window“Input” -----	162
5.6.1. Temperature probe -----	163

5.6.2. Binary input -----	166
5.7. Parameter window“Logic function” -----	172
5.7.1. Parameter window“AND/OR/XOR” -----	174
5.7.2. Parameter window“Gate forwarding” -----	177
5.7.3. Parameter window“Threshold comparator” -----	179
5.7.4. Parameter window“Format convert” -----	182
5.7.5. Parameter window“Gate function” -----	183
5.7.6. Parameter window“Delay function” -----	185
5.7.7. Parameter window“Staircase lighting” -----	186
5.8. Parameter window“Scene Group function” -----	188
Chapter 6 Description of Communication Object -----	192
6.1. “General”Communication Object -----	192
6.2. “Internal sensor measurement”Communication Object -----	198
6.3. “Button”Communication Object -----	199
6.3.1. Individual/Rocker button -----	199
6.3.2. Slap function -----	215
6.4. “Room temperature”Communication Object -----	217
6.5. “Input”Communication Object -----	225
6.6. “Logic function”Communication Object -----	229
6.6.1. “AND/OR/XOR” Communication object -----	229
6.6.2. “Gate forwarding” Communication object -----	230
6.6.3. “Threshold comparator” Communication object -----	231
6.6.4. “Format convert” Communication object -----	232
6.6.5. “Gate function” Communication object -----	234
6.6.6. “Delay function” Communication object -----	235
6.6.7. “Staircase lighting” Communication object -----	236
6.7. “Scene group function” Communication object -----	237
Chapter 7 Icon list -----	239

Chapter 1 Introduction

KNX Glass Sensor GS3 are mainly applied in building control system, connecting to the bus via KNX connection terminals and installing together with other devices on the bus to build a system. They are functionally simple and intuitive to operate. Users can plan according to their own needs to perform these functions in the system.

The manual provides detailed technical information about the KNX Glass Sensor GS3, including installation and programming details, and explains how to use the panel in conjunction with examples in actual use.

KNX Glass Sensor GS3 are powered via KNX bus, installing in a standard 80 or 86-box wall mounting. The physical address assignment and parameter settings can be used with the engineering tool software ETS (version ETS5.7 or above) with the .knxprod file.

The functions are summarized as followed:

- Function pages: select individual or rocker button, support disable function and flashing function (Standard version supports up to 3; Pro version supports up to 5)
- Supports multi-language display (Standard version only supports German, English, French, Spanish, Italian; Pro version supports global languages)
- Individual button support Switch, Dimming, RGB, RGBW, Colour temperature control, Value sender, Scene, Blind, Shift register, Multiple operation, Delay mode, Status display
- Rocker button only support Switch, Dimming, Scene, Blind, Setpoint adjustment
- Support slap operation of Switch and Scene; Enter cleaning mode via combine operation
- Display the function and status of buttons, optional with icon, text, status value etc.
- Status LED indication for button function
- Brightness adjustment for page switchover and screen backlight: Auto/Manual
- Panel lock, Screen saver, Alarm function, Colorful strip function (Apply to pro version), Touch tone setting
- Three sensitivity level of proximity setting, Built-in temperature / humidity sensor

- Room temperature controller, support heating, cooling control modes, and HVAC modes, with 2-pipes or 4pipes system, Temperature logic algorithm supports 2-point and PI control, and Fan auto.control
- Support 2 external input interfaces, used as dry contact detection or NTC temperature detection(Apply to pro version)
- Support 8 Scene Group functions, and 8 outputs for per Scene Group(Apply to pro version)
- Support 8 Logic functions, with AND, OR, XOR, Gate forwarding, Threshold comparator, Format convert, Gate function, Delay function and Staircase lighting
- Support the KNX Data Secure

Chapter 2 Technical characteristic

Power Supply	Bus voltage	21-30V DC, via the KNX bus
	Bus current	<26.5mA/24V; <20.5mA/30V
	Bus consumption	<0.64W
Input	2 external inputs, as dry contact input or 10K NTC input	
Connection	KNX	Bus connection terminal
	Input	A three-wires connection terminal, cable
Operation and display	Programming button and red LED	For assigning the physical address
Proximity sensor	Normal: 10-30cm; Enhanced: 40-60cm; High: 70-100cm Note: the data is referred from internal laboratory, there may be differences in results depending on the person	
Temperature	Operation	-5 °C ... + 45 °C
	Storage	-25 °C ... + 55 °C
	Transport	-25 °C ... + 70 °C
Environment	Humidity	<93%, except dewing
Mounting	European 80 type wall-mounted box or 86 type wall-mounted box	
Dimension/Weight	92*92*35.6mm/0.21kg	

Chapter 3 Dimension and connection diagram

3.1. Dimension drawing

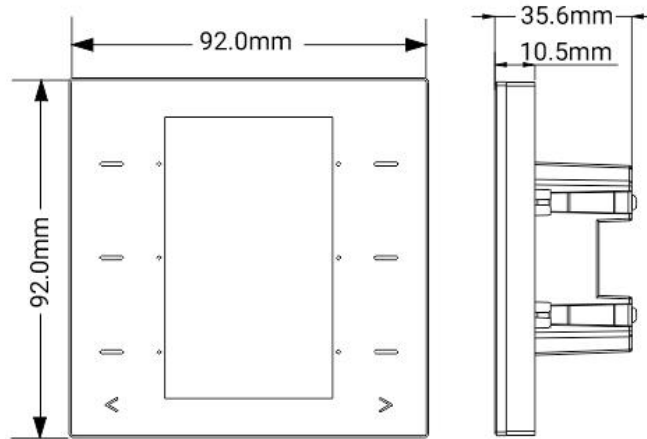

3.2. Connection diagram

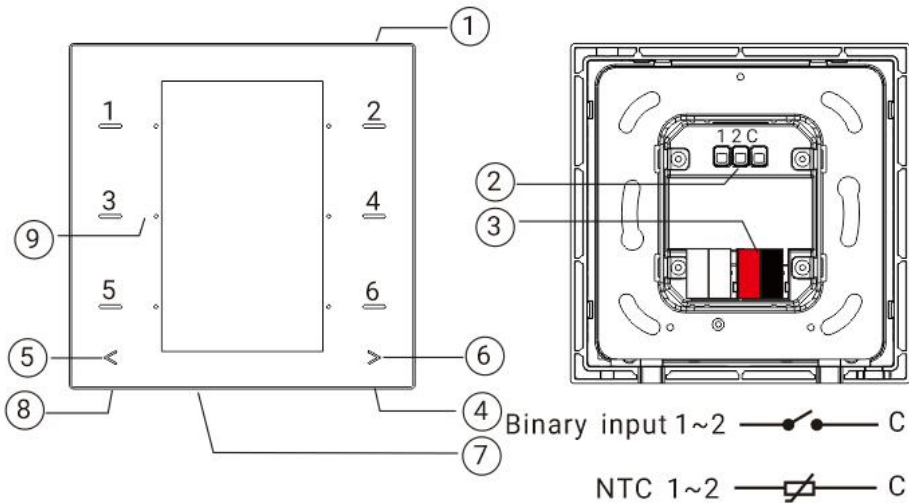

CHTBD-06/5.2.1x

- ① Internal brightness sensor ② Input terminals ③ KNX bus connection terminal
- ④ Programming button ⑤ Previous page switchover LED
- ⑥ Next page switchover LED / Programming LED ⑦ Colorful strip
- ⑧ Internal temperature / humidity sensor ⑨ Proximity sensor

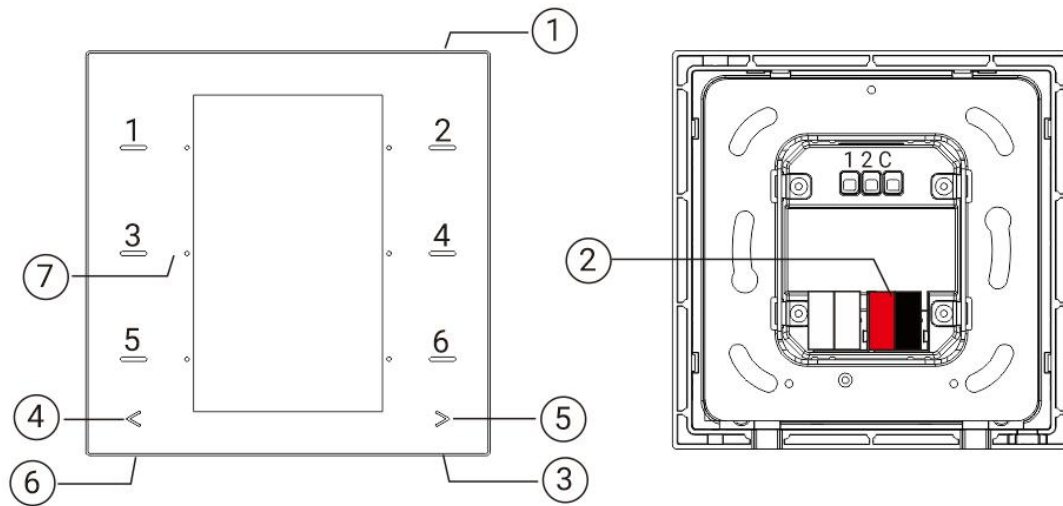

CHTBD-06/3.2.1x

- ① Internal brightness sensor
- ② KNX bus connection terminal
- ③ Programming button
- ④ Previous page switchover LED
- ⑤ Next page switchover LED / Programming LED
- ⑥ Internal temperature / humidity sensor
- ⑦ Proximity sensor

Reset the device to the factory configuration: press the programming button and hold for 4 seconds then release, repeat the operation for 4 times, and the interval between each operation is less than 3 seconds

Chapter 4 Application programming introduction

Application	Maximum of communication objects	Maximum number of group addresses	Maximum number of associations	Secure group addresses
Button/Display/Input/RTC controller/00D7 1.2	657	1200	1200	648
Button/Display/RTC controller/00DC 1.2	657	1200	1200	648

General function

General function includes device In operation setting, date and time update, request device status after voltage recovery, and supports to lock the whole device.

Support to set other functions, including screen brightness, screen saver, proximity sense, colorful strip setting(Apply to pro version) and alarm function.

Internal temperature and humidity measurement

Internal temperature and humidity measurement value is sent to the bus: respond after read only and respond after change.

Set temperature and humidity calibration, and send alarm telegram when the preset range of threshold value for temperature alarm is exceeded.

External input interface function(Apply to pro version)

Up to support 2 channels, enable/disable each channel functions. Optional dry contact detection or NTC temperature detection.

When selecting dry contact detection, only supports the basic functions, including switch, scene send strings (press/release, short/long, send after voltage recovery, disable function).

When selecting NTC temperature detection, the external temperature probe can be connected to detect the external temperature and the B value data of temperature sensing probe needs to be set.

Button function

Button can be used as individual or rocker button. You can set for each button to display on screen with the icon, text, status, etc.

When used as individual button, you can configure: Switch, Dimming, RGB switching/send value, RGBW switching/send value, Colour temperature switching/send value, Value sender, Scene control, Blind, Shift register, Multiple operation, Delay mode, Status display, RGB dimming, RGBW dimming, Colour temperature dimming and Colour temperature adjustment.

When used as rocked button, you can configure: Switch, Dimming, Scene control, Blind, Setpoint adjustment.

In addition, it can be used as slap function, trigger function when at least 2 buttons locating in the same side are pressed, you can configure: Switch, Scene.

Indication LED function

Brightness level of indication LED is adjustable, and adjusted according to normal/night status, standby mode and page switchover. And set the delay time for entering standby mode and for LED status all turned off.

The indication settings for button functions:

①Disable, Via button switch status object, Via external status object (1bit/1byte), Always, Indicate button press (Flash and Always on), Same as Status display indication.

②The LED indication colour can be set independently. When customized colour is used, Customized colour configuration is required.

Room temperature controller

Support to functions, including control mode input, heating/cooling system (compatible with 2/4 pipes system), 4 operation modes (comfort, standby, economy and protection modes) and setpoint temperature, fan speed, window contact, presence detector, temperature threshold, 2 points and PI control algorithm and etc; At relative adjustment, extra optional whether to enable setpoint temperature offset value, with threshold option (-10~10°C), send the offset value to bus when enable.

Logic function

Up to support 8 channels of logic, each channel up to support 8 inputs and 1 logic result.

Logic function support functions, including AND, OR, XOR, Gate forwarding, Threshold comparator, Format convert, Delay function and Staircase lighting.

Scene group function(Apply to pro version)

Up to support 8 channels of scene group forward, each group up to support 8 configurable output, datatype is optional 1bit/1byte/2byte/3byte/6byte.

Chapter 5 Parameters setting description in the ETS

The following will take the KNX Glass Sensor GS3 Pro as an example to illustrate, the consistent functions of the standard version and the pro version will not repeat detailed descriptions here.

5.1.KNX secure

KNX Glass Sensor GS3 is a KNX device that complies with the KNX secure standard. That is, you can run the device in safe way.

KNX Data Secure

i KNX Data Secure is available in this device, it effectively protects user data against unauthorised access and manipulation by means of encryption and authentication for the installation.

i ETS can active or deactivate security function. Detailed specialist knowledge is required.

Device certificate

i The device certificate label stick called FDSK is attached beside the device, and must use for security function, make sure keep securely.

Fig.5.1 (1) "KNX Secure" parameter window

The device with KNX secure will be displayed notes on ETS, as shown as Fig.5.1(1).

If secure commissioning is activated in ETS project, the following information must be considered during device debugging:

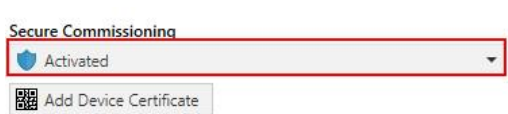

❖ It is essential to assign a project password as soon as a KNX Secure device is imported into a project. This will protect the project against unauthorized access.

The password must be kept in a safe place – access to the project is not possible without it (not even the KNX Association or device manufacturer will be able to access it)!

Without the project password, the commissioning key will not be able to be imported.

- ❖ A commissioning key is required when commissioning a KNX Secure device (first download).

This key (FDSK = Factory Default Setup Key) is included on a sticker on the side of the device, and it must be imported into the ETS prior to the first download:

- ❖ On the first download of the device, a window pops up in the ETS to prompt the user to enter the key, as shown in Fig.5.1 (2) below.

The certificate can also be read from the device using a QR scanner (recommended).

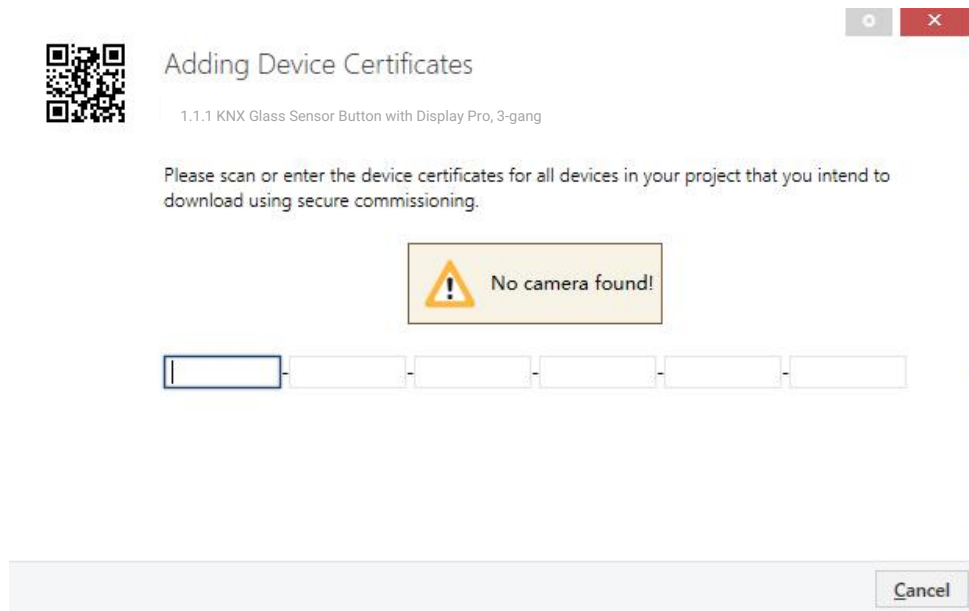

Fig.5.1(2) Add Device Certificate window

- ❖ Alternatively, the certificates of all Secure devices can be entered in the ETS beforehand.

This is done on the "Security" tab on the project overview page, as shown in Fig.5.1(3) below.

The certificates can be also added to the selected device in the project, as shown in

Fig.5.1(4).

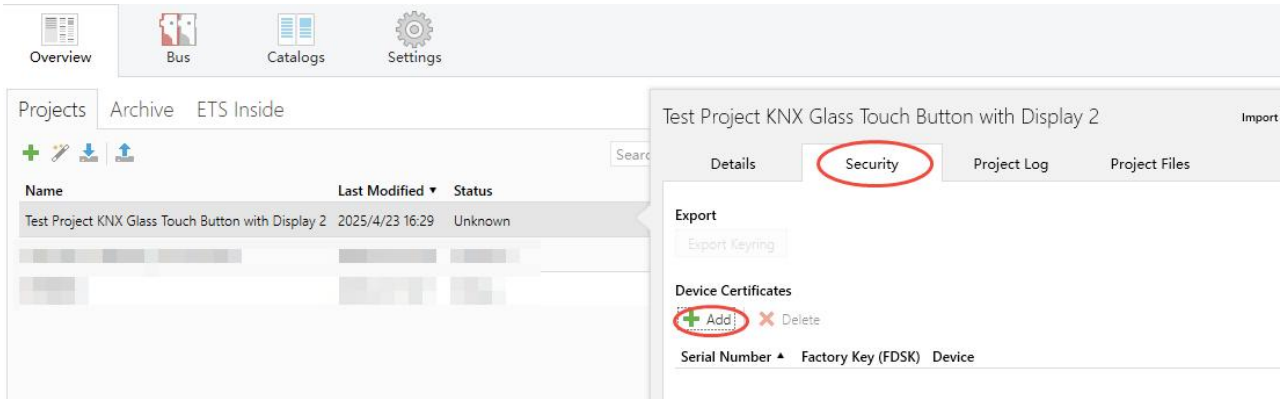

Fig.5.1(3) Add Device Certificate

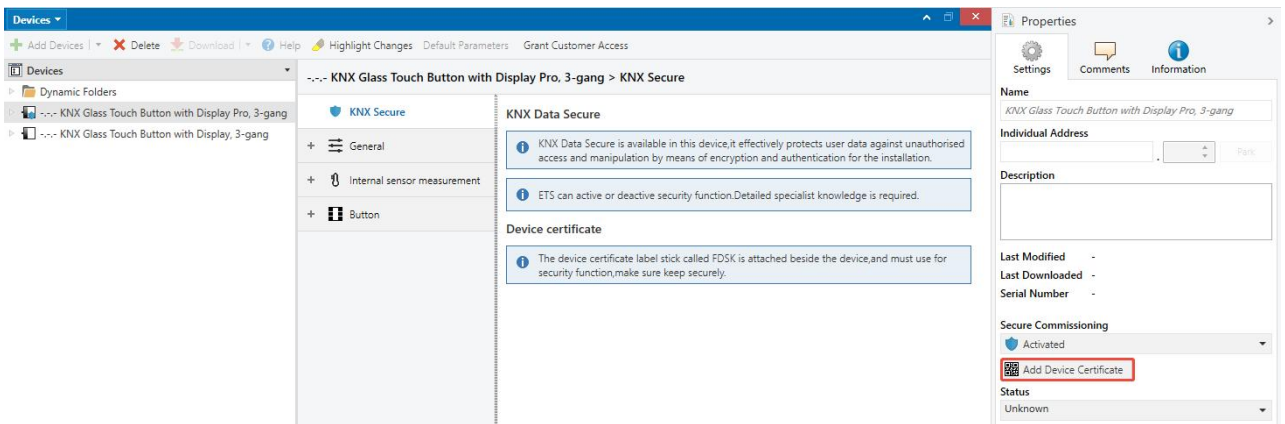

Fig.5.1(4) Add Device Certificate

❖ There is a FDSK sticker on the device, which is used for viewing FDSK number.

Without the FDSK, it will no longer be possible to operate the device in KNX Secure mode after a reset.

The FDSK is required only for initial commissioning. After entering the initial FDSK, the ETS will assign a new key, as shown in Fig.5.1(5) below.

The FDSK will be required again only if the device was reset to its factory settings (e.g. If the device is to be used in a different ETS project).

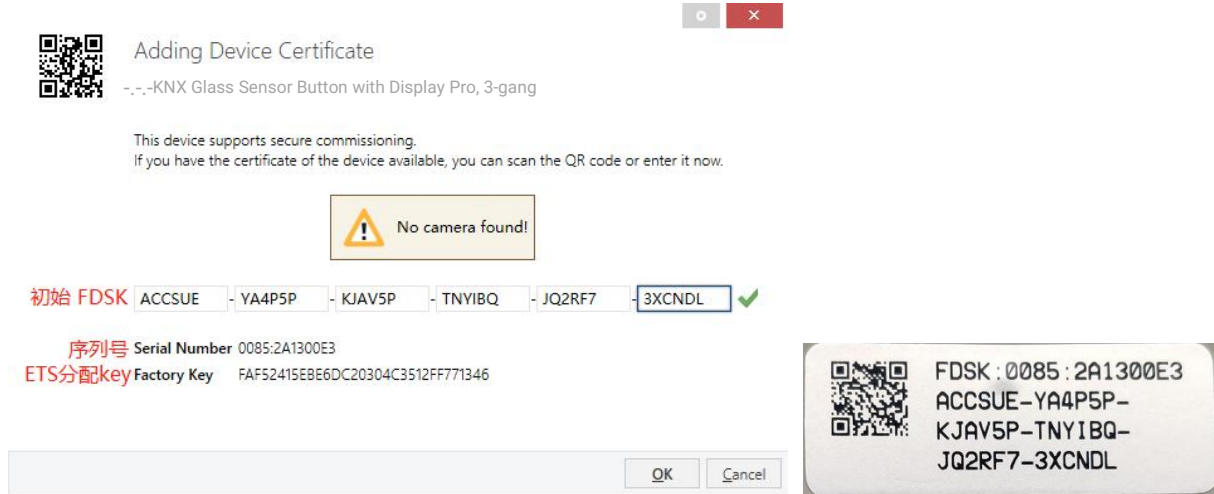

Fig.5.1(5)

Example:

If this application in the project needs to be tried with another device, it is no longer the original device. When the application is downloaded to a new device, the following prompt will appear on the left of Fig.5.1(6), click yes, the Add Device Certificate window will appear, then enter the initial FDSK of the new device, and you need to reset the device to the factory settings (it is not required if the device is still factory default; If it has been used, it will be required to reset, otherwise the following error message will appear on the right of Fig.5.1(6)), and then the device can be successfully downloaded again.

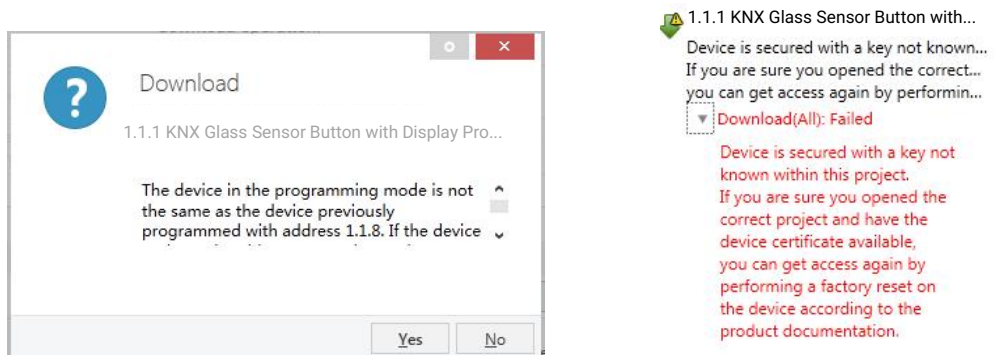

Fig.5.1(6) Example

Whether the device is replaced in the same project, or the device is replaced in a different project, the processing is similar: **Reset the device to the factory settings, then reassign the FDSK.**

After the device is downloaded successfully, the label Add Device Certificate turns gray, indicating that the key for this device has been assigned successfully, as shown in Fig.5.1(7) below.

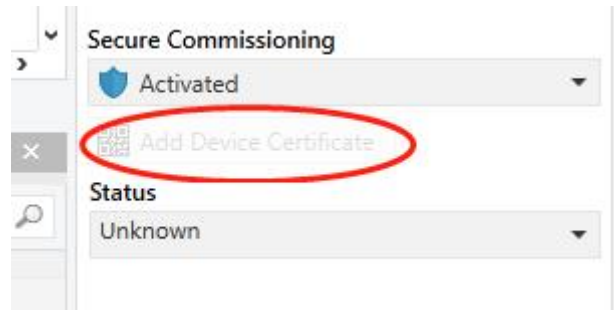

Fig.5.1(7)

ETS generates and manages keys:

Keys and passwords can be exported as needed to the use of security keys outside of the associated ETS projects. As shown in Fig.5.1(8) below, the file extension is .knxkeys.

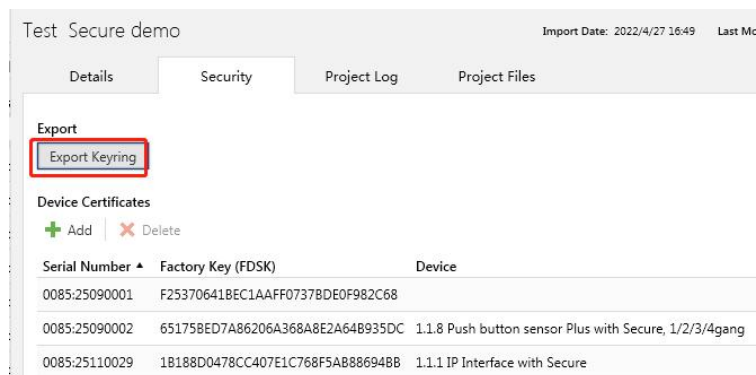

Fig.5.1(8)

Note: Any USB interface used for programming a KNX Secure device must support "long frames".

Otherwise ETS will report a download failure information, as shown below.

5.2.Parameter window“General”

5.2.1.Parameter window“General setting”

Send delay after voltage recovery [0..15]	<input type="text" value="0"/>	s
Send cycle of In operation telegram [1..240,0=inactive]	<input type="text" value="0"/>	s
Long operation for button after [5..250]	<input type="text" value="5"/>	*0.1s

Screen display setting

Codepage option in the property of project for description and unit text UTF-8 ISO8859-1

i Note:The codepage option in the property of project must select the Unicode(UTF-8)

The encode data of telegram for 14byte object from bus UTF-8 ISO8859-1

UI theme is Dark style Light style

Extension function

Screen saver

Night mode

Proximity function

Alarm function

Panel locking function

Allow to wake up for button operation or proximity trigger when the screen is off and locked

Send extension scene command when locking at day

Scene NO.

Send extension scene command when locking at night

Scene NO.

Colorful strip function	<input checked="" type="checkbox"/>
Type of touch tone	5
Allow to enter cleaning mode via combine operation	<input checked="" type="checkbox"/>
<div style="border: 1px solid #ccc; padding: 5px; background-color: #e6f2ff;"> <p>i Combine operation definition is any one of left side and any one of right side press simultaneously and the duration>5s</p> </div>	
Delay time for exiting cleaning mode	30 s

Fig.5.2.1 Parameter window“General”

Parameter“Send delay after voltage recovery [0..15]”

This parameter is for setting the delay time to send to bus after the device voltage recovery.

Options: **0..15 s**

The setting dose not contain the device initialization time, and bus telegrams received during delay time will be recorded.

Parameter“Send cycle of “In operation” telegram [1..240,0=inactive]”

This parameter is for setting the time interval when cyclically send telegrams through the bus to indicate this device in normal operation. When set to “0”, the object “In operation” will not send a telegram. If the setting is not “0”, the object “In operation” will send a telegram according to the setting period time with logic “1” to the bus. Options: **0...240 s,0= inactive**

As to reduce the bus load as much as possible, the maximum time interval should be selected according to actual application requirement.

Parameter“Long operation for button after [5..250]”

This parameter is for setting the valid time of long operation for button. Options: **5..250 *0.1s**

Screen display setting

Parameter“Codepage option in the property of project for description and unit text”

This parameter is for setting the codepage of the project. Options:

UTF-8

ISO8859-1

UTF-8: The codepage option in the property of project must select the Unicode(UTF-8)

i Note: The codepage option in the property of project must select the Unicode(UTF-8)

ISO8859-1: The codepage option in the property of project must be "Windows System Language" or "Western European(ISO8859-1)" and your PC location is in Western European country in order to display normally

i Note: The codepage option in the property of project must be "Windows System Language" or "Western European(ISO8859-1)" and your PC location is in Western European country in order to display normally

Codepage setting as shown as follow:

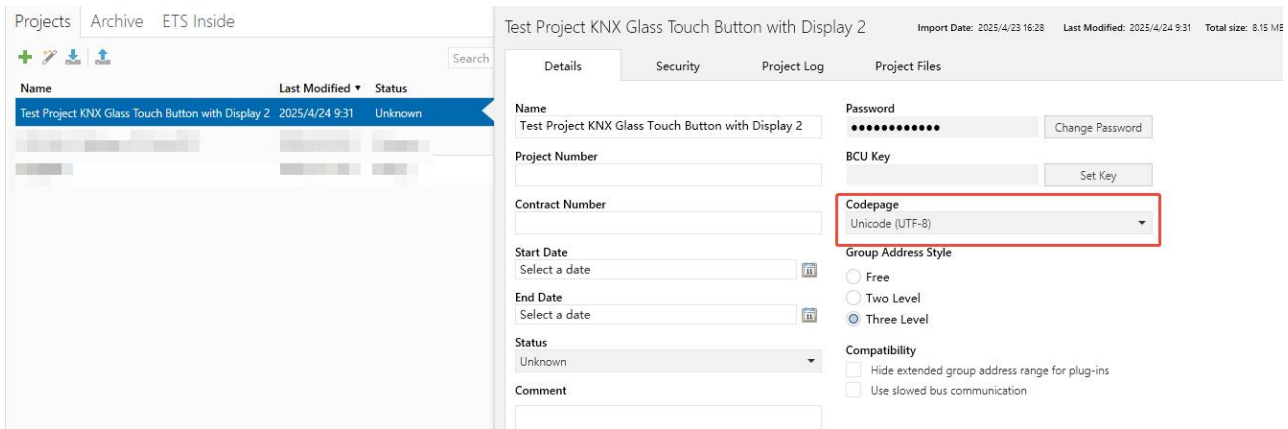

Parameter "The encode data of telegram for 14byte object from bus"

This parameter is for setting the encode data of telegram for 14byte object from bus. Options:

UTF-8

ISO8859-1

Parameter "UI theme is"

This parameter is for setting the UI theme, and can also switch it via the bus. Options:

Dark style

Light style

Dark style is close to black, light style is close to white.

Extension function**Parameter "Screen saver"**

Setting interface of screen saver will be visible when the parameter enabled. This function is described in detail in chapter 5.2.3.

Parameter "Night mode"

Setting interface of night mode will be visible when the parameter enabled. This function is described in detail in chapter 5.2.4.

Parameter "Proximity function"

Setting interface of proximity function will be visible when the parameter enabled. This function is described in detail in chapter 5.2.5.

Parameter "Alarm function"

Setting interface of alarm function will be visible when the parameter enabled. This function is described in detail in chapter 5.2.7.

Parameter "Panel locking function"

This parameter is for setting whether to enable panel locking function. Options:

Disable

Unlock=1/Lock=0

Unlock=0/Lock=1

After receiving the telegram of panel lock, the screen switches to the lock interface, as shown in

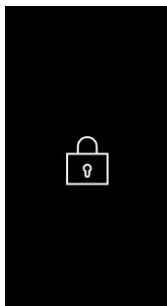

the right figure:

After receiving the unlock signal, it automatically returns to the normal function interface, or enters the screen saver interface after a delay.

Panel lock priority: panel locking function > button locking > indication

—Parameter“Allow to wake up for button operation or proximity trigger when the screen is off and locked”

This parameter is for setting whether allow to wake up for button operation or proximity trigger when the screen is off and locked.

—Parameter“Send extension scene command when locking”

—Parameter“Send extension scene command when locking at day”

—Parameter“Send extension scene command when locking at night”

These parameter are for setting whether to enable send extension scene command when locking, you can set the scene number and scene object when enabled. If night mode is enabled, the scene numbers at day/night can be configured independently.

When the panel is locking, operate any buttons to send the scene number.

—Parameter“Scene NO.”

This parameter is visible when previous parameter is enabled. Set the sending scene number, corresponding telegram is 0~63. Options:

Scene NO.1

Scene NO.2

Scene NO.3

...

Scene NO.64

Parameter“Colorful strip function”

This parameter is for setting interface of colorful function will be visible when the parameter enabled.This function is described in detail in chapter 5.2.6.

参数 “type of touch tone”

This parameter is for setting whether to enable type of touch tone. When enabled, clicking the button will sound a touch tone. Options:

Disable

1

...

5

Parameter “Allow to enter cleaning mode via combine operation”

This parameter is for setting whether to enable cleaning mode function.

When enabled, combine operation definition is any one of left and any one of right side press simultaneously any the duration > 5s.

i Combine operation definition is any one of left side and any one of right side press simultaneously and the duration > 5s

——Parameter “Delay time for exiting cleaning mode”

This parameter is visible when previous parameter is enabled. Set delay time for exiting cleaning mode. After the delay time ends, it will return to page 1, and any touch screen operations during the timing period is invalid.

5.2.2. Parameter window "Brightness setting"

Woke mode of brightness adjustment	<input type="radio"/> Auto <input checked="" type="radio"/> Manual
Screen&LED brightness in normal mode	100 %
Screen&LED brightness in night mode	30 %
Screen&LED brightness can be changed via bus	<input checked="" type="checkbox"/>
LED indication for page switchover	Manual
Brightness for page switchover	40 %
Delay time for turn off screen at day [0..255]	30 s
Delay time for turn off screen at night [0...200]	30 s
Button command execute when screen is off	<input checked="" type="checkbox"/>
Behaviour of waking up screen&LED when proximity trigger or button operation	<input checked="" type="radio"/> Enter screen saver page <input type="radio"/> Enter function page

Fig.5.2.2 Parameter window "Brightness setting"

Parameter "Work mode of brightness adjustment"

This parameter is for setting the screen&LED brightness adjustment mode. Options:

Auto

Manual

Auto: Adjust the screen&LED brightness according to the detection value of the Internal brightness sensor, adjustment range: 10%~100%.

Manual: The screen&LED brightness is set according to the following parameter.

Parameter as follow are visible when "Manual" is selected:

—Parameter "Screen&LED brightness in normal mode"

This parameter is for setting the screen&LED brightness level when normal or day mode (some

one proximity/operation). Options:

10%

20%

...

90%

100%

User can change brightness via object "Screen&LED brightness". Voltage failure or exit day mode, the new brightness value will also be stored.

—Parameter "Screen&LED brightness in night mode"

This parameter is visible when night mode is enabled. Set the the screen&LED brightness level when night mode (some one proximity/operation). Options:

10%

20%

...

90%

100%

Unchanged

User can change brightness via object "Screen&LED brightness". Voltage failure or exit night mode, the new brightness value will also be stored.

When "Unchanged" is selected, the brightness remains at the brightness of day mode, user can only change the brightness temporarily via the object. Voltage failure or exit night mode, the new brightness value will be not stored.

—Parameter "Screen&LED brightness can be changed via bus"

This parameter is for setting whether the screen&LED brightness can be changed via bus.

If enabled, the object "Screen&LED brightness" is visible. It is only used to change the brightness of current status. E.g. if it is currently day mode, only the brightness settings in day mode are updated.

Brightness of screen saver can not be changed via the object.

Parameter "LED indication for page switchover"

This parameter is for setting whether to enable LED indication for page switchover, and can also enable or disable it via 1bit object. Options:

Disable

Auto

Manual

Auto: Adjust the switchover LED brightness according to the detection value of the Internal brightness sensor, adjustment range: 10%~100%.

Manual: The switchover LED brightness is set according to the parameter "Brightness for page switchover".

Note: The switchover LED will turn off when the screen is off. Additionally, when in the screen saver, you can set the LED is available or not, which can be set in Parameter window "Screen saver setting".

——Parameter "Brightness for page switchover"

This parameter is visible when "Manual" is selected. Set the LED brightness for page switchover.

Options: **0...100%**

Parameter "Delay time for turn off screen(&LED)[0..255]"

Parameter "Delay time for turn off screen(&LED)[0..255] at day"

Parameter "Delay time for turn off screen(&LED)[0..200] at night"

This parameter is for setting the delay time that off screen after no operation or enter screen saver.

When night mode is disabled, options: **0..255 s**

When night mode is enabled, options at day: **0..255 s**; options at night: **0..200 s**

When the value is 0, there is a object "Screen&LED on/off" for controlling on/off screen via bus.

Parameter "Button command execute when screen(&LED) is off"

This parameter is for setting whether the button command is executed when screen is off. When enabled, the function of page 1 is executed by default.

Parameter "Send extension scene command when screen(&LED) is off"

Parameter "Send extension scene command when screen(&LED) is off at day"

Parameter "Send extension scene command when screen is off at night"

These parameter are for setting whether to enable send extension scene command when screen is off, you can set the scene number and scene object when enabled. If night mode is enabled, the scene numbers at day/night can be configured independently.

When the screen is off, operate any buttons to send the scene number.

—Parameter "Scene NO."

This parameter is visible when previous parameter is enabled. Set the sending scene number, corresponding telegram is 0~63. Options:

Scene NO.1

Scene NO.2

Scene NO.3

...

Scene NO.64

Parameter "Wake up screen(&LED) when proximity trigger or button operation after turn off via bus"

This parameter is visible when delay time for turn off is set to 0 and turn off LED. Set whether to wake up screen and turn on LED when proximity trigger or button operation after turn off via bus.

If you select to enter the screen saver page when the screen is on, the LED will remains off.

If you select to enter the function page when the screen is on, the LED will turn on with the screen and then turn off together at the end of the delay.

If the screen saver function is disabled, the screen and LED turn off together.

—Parameter“Delay time for automatically turn off screen(&LED) again[0...255]”

This parameter is visible when previous parameter is enabled. Set the delay time for automatically turn off screen and turn off LED. When the value is 0, there is a object “Screen on/off” for controlling on/off screen via bus.

Options: **0..255 s**

Display following information when previous parameter is disabled:



In this case,then the screen will recover only after receiving a screen on telegram,please check to avoid discussion

Parameter“Behaviour of waking up screen(&LED) when proximity trigger or button operation”

This parameter is for setting the behaviour of waking up screen and turn off LED when proximity trigger or button operation. Options:

Enter screen saver page

Enter function page

When the function of screen saver is disabled, “Enter screen saver page” is not visible.

5.2.3.Parameter window“Screen saver setting”

Screen brightness in screen saver in normal mode	50	%
Delay time for normal to screen saver & turn off LED [5..255]	30	s
Date and Time display in screen saver	Date and Time	
Date display format in screen saver	<input type="radio"/> yyyy/mm/dd <input checked="" type="radio"/> dd/mm/yyyy	
Time period for request Date and Time	0	h
Button command execute in screen saver	<input checked="" type="checkbox"/>	
LED indication for page switchover in screen saver	<input checked="" type="checkbox"/>	
Exit screensaver when proximity approach	<input checked="" type="checkbox"/>	
<hr/>		
Items 1 display function	Int. temperature	
Description (Valid display is up to 6 chars for Chinese while 9-11 chars for others,please check on screen)	<input type="text"/>	
Colour for value	Foreground	
Text for unit	°C	
<hr/>		
Items 2 display function	Int. humidity	
Description (Valid display is up to 6 chars for Chinese while 9-11 chars for others,please check on screen)	<input type="text"/>	
Colour for value	Foreground	
Text for unit	%	
<hr/>		
Items 3 display function	None	
<hr/>		
Time period for request external sensor [0..255]	0	min

Fig.5.2.3 Parameter window“Screen saver setting”

Parameter "Screen brightness in screen saver in normal mode"

This parameter is for setting screen brightness level in screen saver in normal mode. Options:

10%

30%

...

100%

Parameter "Screen brightness in screen saver in night mode"

This parameter is visible when "night mode" is enabled, used to set the backlight brightness level for the screen saver in night mode. Options:

10%

30%

...

100%

Parameter "Delay time for normal to screen saver & turn off LED [5..255]"

This parameter is for setting the delay time for normal mode to screen saver and turn off LED.

Options: **5..255 s**

Parameter "Date and Time display in screen saver"

This parameter is for setting whether to display the time/date in screen saver and modify the time/date via the object "Date".

Options:

Disable

Only Date

Only Time

Date and Time

—Parameter "Date display format in screen saver"

This parameter is visible when "Only Date" or "Date and Time" is selected. Set the date display

format in screen saver. Options:

yyyy/mm/dd

dd/mm/yyyy

—Parameter“Time period for request Date and Time”

This parameter is visible when “Disable” is not selected. Set the time period for request Date and Time. If it is 0, it is not set and no request will be sent. Options:

0 h

1 h

2 h

...

96 h

168 h

Parameter“Button command execute in screen saver”

This parameter is for setting whether the button command is executed in screen saver.

Parameter“LED indication for page switchover in screen saver”

This parameter is visible when LED indication for page switchover is enabled. Set whether LED indication for page switchover is available in screen saver.

When it is enabled, the LED will be turn on as configuration after entering the screen saver. When disabled, the LED will be turn off and no any indication.

Parameter“Exit screensaver when proximity approach”

This parameter is for setting whether exit screensaver and enter function page when proximity approach.

Disabled: When in screen saver page, proximity detection is ignored. The screen saver page exits to the function page only after a button operation.

Enabled: When in screen saver page, detection proximity (detecting a change from occupied to unoccupied) will exits the screen saver page and enters the function page (defaulting to the first page).

If the screen is off, proximity detection triggers the screen wake-up, depending on the wake-up settings. If the wake-up setting chooses to enter the screen saver page, it will first enter the screen saver page, only when proximity is detected again will enter the function page. If the wake-up setting chooses to enter the function page, it will directly enter the function page.

Parameter "Items x display function" (x=1~6)

This parameter is for setting the item that is displayed in screen saver, up to 6 items, at least 2 items. Options:

None	1byte unsigned value
Int. temperature	2byte unsigned value
Int. humidity	2byte float value
Ext. temperature	4byte unsigned value
Ext. humidity	4byte float value
1bit value	14byte string
1byte percent value	

Note: When selecting "4byte unsigned value" and "4byte float value", the data displayed on the screen cannot exceed 9 digits.

When no selecting "None", the following parameters are visible. There is no the option "None" for item 1/2.

——Parameter "Description (Valid display space is up to 6 chars for Chinese while 9-11 chars for others, please check on screen)"

This parameter is for setting the description of the screen saver display information, valid display space is up to 6 chars for Chinese while 9-11 chars for others, please check on screen.

——Parameter "Colour for icon"

This parameter is for setting the icon colour for air quality information using. Options:

Foreground	Cyan blue
Red	Cyan
Dark green	Coffee
Blue	Light orange
Yellow	Customized colour 1
Orange	Customized colour 2
Purple	Customized colour 3
Grey	Customized colour 4
Pink	Customized colour 5

—Parameter“Status text for 1-ON”

—Parameter“Status text for 0-OFF”

These parameters are visible when “1bit” is selected. Set the text to display when telegram 0 and 1.

—Parameter“Text for unit”

This parameter is for setting the text for unit. When temperature or humidity, read only °C or %; while “1byte/2byte/4byte” is selected, the unit is customization.

—Parameter“Decimal place”

This parameter is visible when “2byte float value” or “4byte float value” is selected. Set the decimal place for float value. Options:

0

1

Note: Temperature and humidity have 1 decimal place by default.

Parameter“Time period for request external sensor [0..255]”

This parameter is for setting the time period for device to send a control value read request to

external sensor after bus recovery or finish programming. Not send when value is 0.

Options: **0..255 min**

5.2.4.Parameter window“Night mode setting”

Polarity of normal/night mode Normal=1/Night=0 Normal=0/Night=1
 Switchover normal/night mode Via object

i Note: Default to normal mode if no response when request after startup

Fig.5.2.4 Parameter window“Night mode setting”

Parameter “Polarity of normal/night mode”

This parameter for setting object value of normal/night mode. Options:

Normal=1/Night=0

Normal=0/Night=1

Parameter “Switchover normal/night mode”

This parameter for setting the switchover way of normal/night status, send status telegrams via object “Night mode” when status change. Read only the option **Via object**

i Note: Default to normal mode if no response when request after startup

Note: default to normal mode if no response when request after startup. That is, screen backlight and LED status indication are according to normal (day) mode to display.

5.2.5. Parameter window "Proximity setting"

The Proximity function triggered via	Sensor or Proximity object
Proximity Sensitivity	Normal
Object type of output value	1bit[On/Off]
Output value	<input type="radio"/> OFF <input checked="" type="radio"/> ON
Delay time for sending [0..65535]	0 s
Whether button operation also serve as a proximity event	<input checked="" type="checkbox"/>

Fig.5.2.5 Parameter window "Proximity setting"

Parameter "The Proximity function triggered via"

This parameter is for setting the trigger way of proximity function. Options:

Sensor

Proximity object

Sensor or Proximity object

When "Sensor or Proximity object" is selected, not send output value when proximity triggered via object.

Parameters as follow are visible when "Sensor" or "Sensor or Proximity object" is selected.

Parameter "Proximity sensitivity"

This parameter is for setting the sensor sensitivity. Options:

Normal

Enhanced

High

Normal is approximately 15cm, enhanced is approximately 30cm, High is approximately 60cm.

Note: This data was obtained under the test conditions of 180cm height, 70kg weight, and about 1m/s approach speed, and the data may vary under different test conditions.

Parameter "Object type of output value"

This parameter is for setting the object type of output value sent to the bus when proximity is

triggered. Options:

No reaction

1bit[On/Off]

1byte[scene control]

1byte[0..255]

1byte[0..100%]

2byte[0..65535]

These two parameters are not visible when “No reaction” is selected.

——**Parameter “Output value”**

This parameter is for setting the output value sent to the bus when proximity approaching/leaving, the range of value is determined by the data type.

——**Parameter “Delay time for sending [0..65535]”**

This parameter is for setting the delay time for sending telegram. Options: **0..65535 s**

Parameter “Whether button operation also serve as a proximity event”

This parameter is for setting whether button operation also serve as a proximity event.

If disabled, button operation only for waking up the screen or executing the button function, but not to send proximity telegram, and only it is sent when the proximity sensor is triggered.

If enabled, the proximity telegram is sent via triggering the proximity sensor, operating button can also.

5.2.6.Parameter window“Colorful strip setting”

Colorful indication strip	<input checked="" type="radio"/> Always active <input type="radio"/> Active when the backlight off
Colorful indication strip work mode when active	Slowly breathing ▼
Colorful indication strip object trigger polarity	<input checked="" type="radio"/> 0=no trigger/1=trigger <input type="radio"/> 1=no trigger/0=trigger
Initial after device startup	<input checked="" type="radio"/> No trigger <input type="radio"/> Trigger
<hr/>	
Brightness	50 ▼ %
Colour setting	Purple ▼
<hr/>	
Colorful strip scene preset	<input checked="" type="checkbox"/>
Brightness	50 ▼ %
RGB value	#FFFFFF
Flash Frequency	10 ↕ *0.1s
Duration time	2 ↕ min
<hr/>	
<p>i Note: If the strip is always on, it may affect the precision of internal temperature detection, and the average of total on time should be not more than 8 hours in per day, otherwise it may affect the normal life of RGB led.</p>	

Fig.5.2.6 Parameter window“Colorful strip setting”

Parameter“Colorful indication strip”

This parameter is for setting the type of control for the colorful indication strip. Options:

Always active

Active when the backlight off

Parameter“Colorful indication strip work mode when active”

This parameter is for setting the colorful indication strip work mode when active, , and can also switch the mode via the bus.

Options:

Permanent on

Slowly breathing

Colour range cycle

Slowly breathing: 5s on 25s off, cycle indication.

Colour range cycle: Cyclic indication in the order of red/Green/Blue/White/Yellow/Cyan/Purple/Orange
/Cyan blue

— **Parameter “Interval time of colour shift [3..255]”**

This parameter is visible when “Colour range cycle” is selected. Set the interval time of colour shift.

Options: **3..255s**

Parameter “Colorful indication strip object trigger polarity”

This parameter is for setting the colorful indication strip object trigger polarity. Options:

0=no trigger/1=trigger

1=no trigger/0=trigger

Parameter “Initial after device startup”

This parameter is for setting the initial after device startup. Option:

No trigger

Trigger

Parameter “Brightness at day”

This parameter is for setting the brightness value at day. Option:

10%

25%

50%

75%

100%

Parameter "Brightness at night"

This parameter is for setting the brightness value at night. Option:

- 0%**
- 10%**
- 25%**
- 50%**
- 75%**
- 100%**

In addition, the brightness in the current mode can be adjusted relatively or absolutely via the bus.

Parameter "Colour setting"

This parameter is not visible when "Colour range cycle" is selected. Set the indication color of the strip. Options:

- | | |
|---------------|------------------------------|
| Red | Cyan blue |
| Green | Customized colour 1 |
| Blue | Customized colour 2 |
| White | Customized colour 3 |
| Yellow | Customized colour 4 |
| Cyan | Customized colour 5 |
| Purple | Receive 1x3byte value |
| Orange | Receive 3x1byte value |

Parameter "Colorful strip scene preset"

This parameter is for setting whether preset a colorful strip indication scene, and can also recall or exit the scene via 1bit object. When recall the scene, indicate as following parameter setting; when exit, it will return to the previous status by default.

Parameter "Brightness"

This parameter is for setting the brightness of colorful strip. Options:

10%

25%

50%

75%

100%

Parameter "RGB value"

This parameter is for setting the colour of colorful strip. Options: **#000000..#FFFFFF**

Parameter "Flash Frequency"

This parameter is for setting the interval of flash frequency. When set to 0, it will in permanent on.

Options: **0..255 *0.1s**

Parameter "Duration time"

This parameter is for setting the duration time of the scene. When set to 0, the scene will not exit, at this time, it can only be stopped through the bus. Options: **0..255 min**



Note: If the strip is always on, it may affect the precision of internal temperature detection, and the average of total on time should be not more than 8 hours in per day, otherwise it may affect the normal life of RGB led.

5.2.7.Parameter window“Alarm setting”

Type of alarm tone at day	5	▼
Type of alarm tone at night	5	▼
Volume of alarm tone at day	3	▼
Volume of alarm tone at night	1	▼
Alarm tone time period	10s	▼
Alarm tone time automatically repeat interval time	1min	▼
When alarm active, warning message via	<input checked="" type="radio"/> Fixed string <input type="radio"/> 14 Bytes string from bus	
Warning string(max 18char.)	<input type="text"/>	
Send acknowledge after confirm the alarm	<input type="radio"/> No <input checked="" type="radio"/> Yes	

Fig.5.2.7 Parameter window“Alarm setting”

Parameter“Type of alarm tone”

Parameter“Type of alarm tone at day”

Parameter“Type of alarm tone at night”

These parameters are for setting the type of alarm tone. Options: **1/2/3/4/5**

If night mode is enabled, the type alarm tone at day/night can be configured independently.

Parameter“Volume of alarm tone”

Parameter“Volume of alarm tone at day”

Parameter“Volume of alarm tone at night”

These parameters are for setting the volume of alarm tone. Options: **1/2/3**. When set to 3, the volume is maximum

If night mode is enabled, the volume tone at day/night can be configured independently.

Parameter“Alarm tone time period”

This parameter is for setting the time period of alarm tone. When receive the alarm telegram, play alarm tone immediately, if currently playing and it will not be interrupted and will not be re-timed. If

receive the cancel alarm telegram when playing, it will be interrupted immediately. Options:

Disable

10s

20s

...

25min

30min

Disable: disable the alarm tone playing function.

Other options: the playing period of alarm tone.

——**Parameter “Alarm tone time automatically repeat interval time”**

This parameter is visible when previous parameter is enabled. Set the interval at which alarm tone time automatically repeat, and the timing is only related to when the last play ended. Options:

Disable

10s

20s

...

25min

30min

Disable: disable the alarm tone repeat function.

Other options: when a playing period complete, it will automatically play again after a delay of the setting time.

Parameter “When alarm active, warning message via”

When alarm activated, this parameter is for setting input type of warning message, either by displaying a fixed string entered by ETS on the screen or by receiving a 14byte string from the bus.

Options:

Fixed string

14 Bytes string from bus

When it is selected "14 Bytes string from bus", display the information according to the encode data:

 The encode data of telegram must be UTF-8 or ASCII characters

 The encode data of telegram must be ISO8859-1 or ASCII characters

After receiving the alarm telegram, the screen switches to the alarm interface, as shown in the



right figure:

After user has operated any button (confirmed the alarm) or receiving the telegram of cancel alarm, it automatically returns to the normal function interface, or enters the screen saver interface after a delay.

—Parameter "Warning string(max 18char.)"

This parameter is visible when "Fixed string" is selected. Set the indicate text when alarm activated.

Parameter "Send acknowledge after confirm the alarm"

This parameter is for setting whether to send a 1bit acknowledge telegram, the action that only needs to be processed when the user clicks on the screen to acknowledge the warning message.

5.2.8. Parameter window "Advance function"

Room temperature controller	<input checked="" type="checkbox"/>
Input interface	<input checked="" type="checkbox"/>
Logic function	<input checked="" type="checkbox"/>
Scene group function	<input checked="" type="checkbox"/>

Fig.5.2.8 Parameter window "Advance function"

Parameter "Room temperature controller"

Setting page of Room temperature controller interface is visible after this parameter enabled. This function is described in detail in chapter 5.5.

Parameter "Input interface"

Setting page of input interface is visible after this parameter enabled. This function is described in detail in chapter 5.6.

Parameter "Logic function"

Setting page of logic function is visible after this parameter enabled. This function is described in detail in chapter 5.7.

Parameter "Scene group function"

Setting page of scene group function is visible after this parameter enabled. This function is described in detail in chapter 5.8.

5.3.Parameter window“Internal sensor measurement”

These parameter pages as follow are used for setting the calibration value, sending condition and error report of internal sensor, if other functions select to use internal sensor, refer to the settings here.

5.3.1.Parameter window“Temperature sensor”

Temperature calibration	0.0	▼	K
Send temperature when the result change by	1.0	▼	K
Cyclically send temperature [0...255,0=inactive]	10	▲▼	min
Send alarm telegram for low/high temperature	Respond after read only	▼	
Threshold value for low temperature alarm [0..15]	0	▼	°C
Threshold value for high temperature alarm [30..45]	45	▼	°C

Fig.5.3.1 Parameter window“Internal sensor measurement”

Parameter“Temperature calibration”

This parameter is for setting the temperature calibration value of the internal sensor, that is, to calibrate the measured value of internal sensor to make it closer to the current ambient temperature.

Options:

-5.0K

...

0.0K

...

5.0K

Note: after the device is powered on, the stability time of internal sensor detection will take 30 minutes, therefore, the detected temperature value in the early stage of device work may be inaccurate.

Parameter“Send temperature when the result change by”

This parameter is for setting when temperature turns to a certain value, whether to enable to send

the current temperature value to the bus. Not send when disable. Options:

Disable

0.1K

0.2K

0.3K

0.5K

1.0K

...

10.0K

Parameter "Cyclically send temperature [0...255,0=inactive]"

Setting the time for cyclically sending the temperature detection value to the bus.

Options: **0..255 min**

This period is independent and starts time counting after programming completion or reset.

Transmission change has no affect on this period.

Parameter "Send alarm telegram for low/high temperature"

This parameter is for setting condition of sending telegram when low/high temperature alarm.

Options:

No respond

Respond after read only

Respond after change

Respond after read only: the object "Low temperature alarm"/"High temperature alarm" will send the alarm status to the bus only when the device receives a read alarm from bus.

Respond after change: the object "Low temperature alarm"/"High temperature alarm" will immediately send the telegram to the bus to report the alarm value when the alarm status has changed.

Parameter as follow are visible when “Respond after read only” or “Respond after change” is selected:

—Parameter “Threshold value for low temperature alarm [0..15]”

This parameter is for setting the threshold value for low temperature alarm. When the temperature lower than low threshold, low temperature alarm object will send telegram. Options:

0°C

1°C

...

15°C

—Parameter “Threshold value for high temperature alarm [30..45]”

This parameter is for setting the threshold value for high temperature alarm. When the temperature higher than high threshold, high temperature alarm object will send telegram. Options:

30°C

31°C

...

45°C

5.3.2. Parameter window "Humidity sensor"

Humidity calibration	0	%
Send humidity when the result change by [0..20]	5	%
Cyclically send humidity [0..255,0=inactive]	10	min
Send alarm telegram for low/high humidity	Respond after read only	
Threshold value for low humidity alarm [5..50]	5	%
Threshold value for high humidity alarm [55..85]	85	%

Fig.5.3.2 Parameter window "Humidity sensor"

Parameter "Humidity calibration"

This parameter is for setting the humidity calibration value of the internal sensor, that is, to calibrate the measured value of internal sensor to make it closer to the current ambient humidity.

Options: **-20% / -15% / -10% / -5% / -3% / -1% / 0% / 1% / 3% / 5% / 10% / 15% / 20%**

Parameter "Send humidity when the result change by [0..20]"

This parameter is for setting when humidity turns to a certain value, whether to enable to send the current humidity value to the bus. Not send when value is 0. Options: **0..20 %**

Parameter "Cyclically send humidity [0..255,0=inactive]"

Setting the time for cyclically sending the humidity detection value to the bus. Options: **0..255 min**

This period is independent and starts time counting after programming completion or reset.

Transmission change has no affect on this period.

Parameter "Send alarm telegram for low/high humidity"

This parameter is for setting condition of sending telegram when low/high humidity alarm.

Options:

No respond

Respond after read only

Respond after change

Respond after read only: the object "Low humidity alarm"/"High humidity alarm" will send the alarm status to the bus only when the device receives a read alarm from bus.

Respond after change: the object "Low humidity alarm"/"High humidity alarm" will immediately send the telegram to the bus to report the alarm value when the alarm status has changed.

These two parameters as follow are visible when "Respond after read only" or "Respond after change" are selected.

—Parameter "**Threshold value for low humidity alarm [5..20]**"

This parameter is for setting the threshold value for low humidity alarm. When the humidity lower than low threshold, low humidity alarm object will send telegram.

Options: **5..20** %

—Parameter "**Threshold value for high humidity alarm [55..85]**"

This parameter is for setting the threshold value for high humidity alarm. When the humidity higher than high threshold, high humidity alarm object will send telegram.

Options: **55..85** %

5.4.Parameter window“Button”

Only apply to RGB dimming/RGBW dimming/Colour temperature dimming

Delay time for auto exiting sub dimming page s

Send telegram after long operation on sub dimming page Only after release Cyclically during press

Flashing indication for individual button long operation

Flashing indication for rocker button press

Display style for icon indication type (it only apply to icon+description of button and icon+status value and status value+Int.temp) Icon/Status above Icon/Status below

Number of page

Interface preview



Slap function

Button 1& 2 use as Individual button Rocker button

Button 3& 4 use as Individual button Rocker button

Button 5& 6 use as Individual button Rocker button

Function of Channel

Description (Valid display space is up to 18 small chars,while 6 Chinese chars)

Fig.5.4 Parameter window“Button”

Only apply to RGB dimming/RGBW dimming/Colour temperature dimming**Parameter "Delay time for auto exiting sub dimming page"**

This parameter is for setting the delay time for auto exiting sub dimming page, only apply to RGB dimming, RGBW dimming, Colour temperature dimming. Telegrams are sent immediately, such as brightness, colour temperature, specific definition is according to the UI. Options: **3..10s**

Parameter "Send telegram after long operation on sub dimming page"

This parameter is for setting the operation concept of send telegram after long operation on sub dimming page, it is only applied to RGB dimming/RGBW dimming/Colour temperature dimming.

Options:

Only after release

Cyclically during press

Only after release: when long operation on sub dimming page, the value of the function operating will change according to the preset step value, but the last value will be sent to the bus only when the button is released.

Cyclically during press: when long operation on sub dimming page, the value of the function operating will change according to the preset step value, and will be sent to the bus, and the cycle is 0.5s.

Parameter "Flashing indication for individual button long operation"

When individual button is selected, the parameter is for setting whether remind user if long operation.

When enabled, if long operation, flashing twice then recover to normal indication, the flashing effect is 1s on and 1s off.

Note: This function is applied to the status LED indicator and is not executed when the status LED indicator function is configured to "indicate button press".

Parameter "Flashing indication for rocker button press"

When rocker button is selected, the parameter is for setting whether remind user if button is

pressed.

When enabled, if button is pressed, flashing twice then recover to normal indication, the flashing effect is 1s on and 1s off.

Note: This function is applied to the status LED indicator and is not executed when the status LED indicator function is configured to “indicate button press”.

Parameter “Display style for icon indication type(it only apply to icon+description of button and icon+status value and status value+Int.temp)”

This parameter is for setting display style for icon indication type. Options:

Icon/Status above

Icon/Status below

Icon/Status above: when “icon+description of button” or “icon+status value” is set, icon displays above description or status value; while “status value+Int.temp” is set, the status value displays above initial temperature value.

Icon/Status below: when “icon+description of button” or “icon+status value” is set, icon displays below description or status value; while “status value+Int.temp” is set, the status value displays below initial temperature value.

Parameter “Number of page”

This parameter is for setting number of page. Options: **1...5 (Standard version supports up to 3; Pro version supports up to 5)**

Parameter “Slap function”

Setting page of slap function is visible after this parameter enabled. This function is described in detail in chapter 5.4.6.

Parameter “Button x& y use as” (x=1/3/5; y=2/4/6)

This parameter is displayed according to the number of page. Set the work way of push button sensor. Options:

Individual button

Rocker button**Parameter "Function of Channel"**

This parameter is for setting the function of button. Option is displayed by the button used.

When individual button is selected, set the function of individual button. The detail configuration of individual button please refer to chapter 5.4.1, chapter 5.4.2 and chapter 5.4.5. Options:

Switch	Shift register
Dimming	Multiple operation
RGB switching/send value	Delay mode
RGBW switching/send value	Status display
Colour temperature switching/send value	RGB dimming
Value sender	RGBW dimming
Scene control	Colour temperature dimming
Blind	Colour temperature adjustment

When rocker button is selected, set the function of rocker button. The detail configuration of rocker button please refer to chapter 5.4.3, chapter 5.4.4 and chapter 5.4.5. Options:

Switch	Blind
Dimming	Setpoint adjustment
Scene control	

5.4.1. Individual button

5.4.1.1. Switch

Function of Channel	Switch
Description (Valid display space is up to 18 small chars,while 6 Chinese chars)	
Distinction between short and long operation	<input type="checkbox"/>
Reaction on press operation	TOGGLE
Reaction on release operation	OFF
Number of objects	<input checked="" type="radio"/> 1 <input type="radio"/> 2
Disable function	Disable=1/Enable=0
Lock Icon indicated when disabled	<input checked="" type="radio"/> Small icon <input type="radio"/> Big icon
Flashing function (indication on screen)	Disable=1/Enable=0
Colour for flashing	Red

Fig.5.4.1.1 Switch

Parameter "Description (Valid display space is up to 18 small chars,while 6 Chinese chars)"

This parameter is for setting the description of individual button, up to input 18 characters.

Note: The valid display space on the screen is up to 18 small chars, while 6 Chinese chars and supports newline display.

Parameter "Distinction between short and long operation"

This parameter is for setting whether to distinction the contact operation between short and long operation.

When select "Enable", the operation reaches a certain time to determine whether the operation is a long or short operation before the contact performs the setting action.

Parameter "Reaction on short/press operation"

Parameter "Reaction on long/release operation"

These parameters are for setting the performed actions when press/release the contact or long/short operation. The object value is updated when the input is determined.

Options:

No reaction

OFF

ON

TOGGLE

No action: no telegrams have been sent.

ON: send the on telegram.

OFF: send the off telegram.

TOGGLE: each operation will switch between on and off. For example, if the last telegram was sent (or received) for on, then the next operation will trigger a telegram for off. When the switch is operated again, it will send a telegram for on etc., So the switch will always remember the previous state and covert to opposite value during next operation. When the device is powered on for the first time or restarted after downloading, the default value for "Switch" is 0, meaning the first operation is ON.

Parameter "Number of objects"

This parameter is visible when the parameters "Reaction on short/press operation" or "Reaction on long/release operation" are not selected "No reaction". Set the number of objects when short/long or press/release operation. Options:

1

2

Parameter "Disable function"

This parameter is for setting trigger value to disable/enable contacts. Options:

Disable

Disable=1/Enable=0

Disable=0/Enable=1

—Parameter “Lock Icon indicated when disabled”

This parameter is not visible when previous parameter is selected “Disable”. Set the icon size when the button is in disable status. Options:

Small icon**Big icon**

Big icon is the lock icon replaces the original icon, e.g. ; while small icon is the two icons

coexist and the lock icon is a small icon in right corner, e.g. .

Parameter “Flashing function”

This parameter is for setting whether to enable flashing function. Options:

Disable**Disable=1/Enable=0****Disable=0/Enable=1****—Parameter “Colour for flashing”**

This parameter is not visible when previous parameter is selected “Disable”. Set the colour for flashing. Options:

Foreground	Cyan blue
Red	Cyan
Dark green	Coffee
Blue	Light orange
Yellow	Customized colour 1
Orange	Customized colour 2
Purple	Customized colour 3
Grey	Customized colour 4
Pink	Customized colour 5

Note: flashing function is only used for “Switch”, “Dimming” and “Blind”.

Function display priority: Lock function >Flashing function > Normal status indication.

If flashing function and lock function are both triggered at the same time, it will interrupt flashing first and the flashing can be resumed only after it is unlocked, cancel flashing then return to the normal status indication.

When enabled flashing function, there will be different flashing effects when pressing buttons depending on the configured indication type: continuous flashing (1s on and 1s off) when icon or description is selected; only icon flashing when “Icon + description” is selected; while the other selection is to flash icon or description or status value, which is according to configuration.

Repeat parameters will not be illustrated below; the usage is similar.

5.4.1.2.Dimming

Function of Channel	Dimming
Description (Valid display space is up to 18 small chars,while 6 Chinese chars)	
Reaction on short operation	TOGGLE
Reaction on long operation	Brighter/Darker
Dimming mode	<input type="radio"/> Start-Stop dimming <input checked="" type="radio"/> Step dimming
Step size	12.5 %
Interval of tele. cyclic send [0..25,0=send once]	0 *0.1s
Disable function	Disable=1/Enable=0
Lock Icon indicated when disabled	<input checked="" type="radio"/> Small icon <input type="radio"/> Big icon
Flashing function (indication on screen)	Disable=1/Enable=0
Colour for flashing	Red

Fig.5.4.1.2 Dimming

Parameter "Reaction on short operation"

This parameter is for setting the the switch value to send when short operation. Options:

No reaction

OFF

ON

TOGGLE

No action: no telegrams have been sent.

ON: send the on telegram.

OFF: send the off telegram.

TOGGLE: each operation will switch between on and off. When the device is powered on for the first time or restarted after downloading, the default value for "Switch" is 0, meaning the first operation is ON.

Parameter "Reaction on long operation"

This parameter is for setting the the relative dimming value to send when long operation, with dimming brighter or darker; when release the contact stop dimming. Options:

No reaction

Brighter

Darker

Brighter/Darker

No action: no telegrams have been sent.

Brighter: send the dimming up value.

Darker: send the dimming down value.

Brighter/darker: each operation will toggle the dimming between up and down. When the device is powered on for the first time or restarted after downloading, the default value for "Dimming" is 0, meaning the first operation is dim up the brightness.

Note: in "TOGGLE" mode of this parameter setting, the value sent will be linked. For example, if the last value is switching on status, then it will be dimmed down in next dimming operation; if the

last value is switching off, then it will be dimmed up in next dimming operation.

—Parameter“Dimming mode”

This parameter is visible when previous parameter is not selected “No reaction”. Set the way of relative dimming. Options:

Start-Stop dimming

Step dimming

Start-stop dimming: the dimming mode will be start-stop, a dimming up or down telegram will be sent when the dimming starts, and a stop telegram will be sent when dimming ends. Here the dimming telegram will not be sent cyclically.

Steps dimming: the dimming mode will be a step one and the dimming telegram will be sent cyclically. When dimming ends, a stop dimming telegram will be sent immediately.

—Parameter“ Step size”

This parameter is visible when the dimming way is selected “Step dimming”. Set a cyclically sending dimming telegram which changes the brightness percentage. Options:

100%

50%

...

1.56%

—Parameter“ Interval of tele. cyclic send [0..25,0=send once]”

This parameter is visible when the dimming way is selected “Step dimming”. Set intervals of telegrams cyclically sending dimming telegram. Options: **0..25*0.1s, 0=send once**

5.4.1.3.RGB switching/send value

Function of Channel	RGB switching/send value
Description (Valid display space is up to 18 small chars,while 6 Chinese chars)	
Object datatype of absolute brightness	<input checked="" type="radio"/> 1x3byte <input type="radio"/> 3x1byte
Reaction on short operation	TOGGLE
Reaction on long operation	Absolute value
RGB Value	#FFFFFF 

Fig.5.4.1.3 RGB switching/send value

Parameter "Object datatype of absolute brightness"

This parameter is for setting the object datatype of absolute brightness. Options:

1x3byte

3x1byte

Parameter "Reaction on short operation"

Parameter "Reaction on long operation"

These two parameters are for setting the sending value when long/short operation.

Options:

No reaction

OFF

ON

TOGGLE

Absolute value

——Parameter "RGB Value"

This parameter is visible when previous parameter is not selected "Absolute value". Set the RGB value when long/short operation. Options: #000000..#FFFFFF

5.4.1.4.RGBW switching/send value



Function of Channel	RGBW switching/send value
Description (Valid display space is up to 18 small chars,while 6 Chinese chars)	
Object datatype of absolute brightness	<input type="radio"/> 1x6byte <input checked="" type="radio"/> 4x1byte
Reaction on short operation	OFF
Reaction on long operation	Absolute value
RGB Value	#FFFFFF 
White Value	255 

Fig.5.4.1.4 RGBW switching/send value

Parameter "Object datatype of absolute brightness"

This parameter is for setting the object datatype of absolute brightness. Options:

1x6byte

4x1byte

Parameter "Reaction on short operation"

Parameter "Reaction on long operation"

These two parameters are for setting the sending value when long/short operation. Options:

No reaction

OFF

ON

TOGGLE

Absolute value

Parameters as follow are visible when “Absolute value” is selected:

—Parameter“RGB Value”

This parameter is for setting the RGB value when long/short operation.Options:#000000..#FFFFFF

—Parameter“White Value”

This parameter is for setting the white value when long/short operation. Options: **0..255**

5.4.1.5.Colour temperature switching/send value

Function of Channel	Colour temperature switching/send value
Description (Valid display space is up to 18 small chars,while 6 Chinese chars)	
Reaction on short operation	Absolute value
Send brightness value	100 %
Send Colour temperature value	4000 K
Reaction on long operation	Absolute value
Send brightness value	100 %
Send Colour temperature value	4000 K

Fig.5.4.1.5 Colour temperature switching/send value

Parameter“Reaction on short operation”
 Parameter“Reaction on long operation”

These two parameters are for setting the sending value when long/short operation. Options:

- No reaction**
- OFF**
- ON**
- TOGGLE**
- Absolute value**

Parameters as follow are visible when “Absolute value” is selected:

—Parameter“Send brightness value”

This parameter is for setting the brightness value when long/short operation. Options: **0..100 %**

—Parameter“Send Colour temperature value”

This parameter is for setting the colour temperature value when long/short operation.

Options: **1000..10000 K**

5.4.1.6.Value sender

Function of Channel	Value sender
Description (Valid display space is up to 18 small chars,while 6 Chinese chars)	<input type="text"/>
Reaction on short operation	1bit value[ON/OFF]
Value 1	<input type="radio"/> OFF <input checked="" type="radio"/> ON
Reaction on long operation	1bit value[ON/OFF]
Value 2	<input checked="" type="radio"/> OFF <input type="radio"/> ON

Fig.5.4.1.6 Value sender

Parameter“Reaction on short operation”

Parameter“Reaction on long operation”

These two parameters are for setting the datatype to send when long/short operation. Options:

- | | |
|----------------------------|-----------------------------------|
| No reaction | 2byte value[0..65535] |
| 1bit value[On/Off] | 2byte float value |
| 2bit value[0..3] | 4byte value[0..4294967295] |
| 4bit value[0..15] | 4byte float value |
| 1byte value[0..255] | |

Parameters as follow are visible when “No reaction” is not selected:

—Parameter“Value 1”

—Parameter“Value 2”

This parameter is for setting the data value to send when perform short/long operation. Range of value is determined according to the previous parameter selected datatype.

5.4.1.7.Scene control

Function of Channel	Scene control ▼
Description (Valid display space is up to 18 small chars,while 6 Chinese chars)	<input type="text"/>
Reaction on short operation	Recall scene ▼
8 bit scene number	Scene No.1 ▼
Reaction on long operation	Recall scene ▼
8 bit scene number	Scene No.1 ▼
Number of objects	<input checked="" type="radio"/> 1 <input type="radio"/> 2

Fig.5.4.1.7 Scene control

Parameter“Reaction on short operation”

Parameter“Reaction on long operation”

These two parameters are for setting to recall or storage scene when long/short operation.

Options:

No reaction

Recall scene

Store scene

Parameters as follow are visible when “Reaction on short operation” or “Reaction on long operation” are not selected “No reaction”:

—Parameter“8 bit scene number”

This parameter is for setting the scene number. Options:

Scene NO.1

Scene NO.2

Scene NO.3

...

Scene NO.64

Corresponding telegram is 0~63.

——**Parameter“Number of objects”**

This parameter is for setting the number of objects when short/long operation. Options:

1

2

5.4.1.8.Blind

Function of Channel	Blind
Description (Valid display space is up to 18 small chars,while 6 Chinese chars)	
Reaction on short operation	Up/Down
Reaction on long operation	Up/Down
<hr/>	
Disable function	Disable=1/Enable=0
Lock Icon indicated when disabled	<input checked="" type="radio"/> Small icon <input type="radio"/> Big icon
Flashing function (indication on screen)	Disable=1/Enable=0
Colour for flashing	Red

Fig.5.4.1.8 Blind

Parameter "Reaction on short operation"

Parameter "Reaction on long operation"

These two parameters are for setting to performed actions when long/short operation. Options:

No reaction

Up

Down

Up/Down

Stop(Adjust Up)

Stop(Adjust Down)

Stop(Adjust Up/Down)

No action: no telegram to be sent.

Up: the blinds will be opened or moved up.

Down: the blinds will be closed or moved down.

Up/Down: alternately open/close or move up/down the blinds. When the device is powered on for the first time or restarted after downloading, the default value for "Up/Down, Blind" is 0, meaning the first operation is closing or moving down the blinds.

Stop (Adjust Up): stop the blind movement or move up the angle of blinds.

Stop (Adjust Down): stop the blind movement or move down the angle of blinds.

Stop (Adjust Up/Down): stop the blind movement or move up/down the angle of blinds alternately.

When the device is powered on for the first time or restarted after downloading, the default value for "Stop/Adjust Blind" is 0, meaning the first operation is stop or move down the angle of blinds.

—**Parameter** "Interval of tele. cyclic send [0..25,0=send once] "

This parameter is visible when the parameter "Reaction on long operation" is selected "Stop...".

Set the time interval of cyclical blinds angle adjustment telegram sent.

Options: **0..25*0.1s,0=send once**

5.4.1.9.Shift register

Function of Channel	Shift register
Description (Valid display space is up to 18 small chars,while 6 Chinese chars)	<input type="text"/>
Shift type	<input checked="" type="radio"/> Shift by step value <input type="radio"/> Shift without step value
Value begin with	0
Value end with(must be larger than value begin with)	10
Step size	2
Direction	From highest to lowest and stop to the begin
Reset function	<input checked="" type="radio"/> Disable <input type="radio"/> Enable by long operation
Shift by step value	
Function of Channel	Shift register
Description (Valid display space is up to 18 small chars,while 6 Chinese chars)	<input type="text"/>
Shift type	<input type="radio"/> Shift by step value <input checked="" type="radio"/> Shift without step value
Object datatype	1byte unsigned value
Shift number	1
Value 1	0
Direction	From highest to lowest and stop to the begin
Reset function	<input checked="" type="radio"/> Disable <input type="radio"/> Enable by long operation
Disable function	Disable=1/Enable=0
Lock Icon indicated when disabled	<input checked="" type="radio"/> Small icon <input type="radio"/> Big icon
Shift without step value	

Fig.5.4.1.9 Shift register

Parameter "Shift type"

This parameter is for setting the shift type. Options:

Shift by step value

Shift without step value

Shift by step value: Here the starting value and stopping value of shift can be set, the value increased (from low to high) or decreased (from high to low) from every shift can also be set.

Shift without step value: When there's no step value, the actual value sent by each shift can be set (max. 10 value), in every operation one value will be sent.

Three parameters as follow are visible when "Shift by step value" is selected:**—Parameter "Value begin with"**

This parameter is for setting the starting value of the shift. Options: **0..240**

—Parameter "Value end with(must be larger than value begin with)"

This parameter is for setting the stopping value of the shift. Options: **1..250**

Note: the values must meet the condition: end value > begin value.

—Parameter "Step size"

This parameter is for setting the increase (from low to high) or decrease (from high to low) value.

Options: **0..240**

Parameters as follow are visible when "Shift without step value" is selected:**—Parameter "Object datatype"**

This parameter is for setting the object datatype for the shift object. Options:

1 byte unsigned value

Scene number

HVAC mode

1 byte percentage

—Parameter "Shift number"

This parameter is for setting the number of shift, up to set 10 values.

When "1 byte unsigned value", "Scene number" or "1 byte percentage" is selected, options:

0/1/2../10

When "HVAC mode" is selected, options: **1/2/3/4**

—Parameter "Value x" (x=1~10 or x=1~4)

This parameter is for setting the value when each shift operation to send, display according to data type.

When "1 byte unsigned value" is selected, options: **0..255**

When "Scene number" is selected, options:

Scene NO.1

Scene NO.2

Scene NO.3

...

Scene NO.64

When "HVAC mode" is selected, options:

Comfort mode

Standby mode

Economy mode

Frost/heat protection

When "1 byte percentage" is selected, options:

0%

1%

...

100%

Parameter "Direction"

This parameter is for setting the shift direction. Options:

From lowest to highest and stop to the end

From highest to lowest and stop to the begin

From lowest to highest and cyclically

From highest to lowest and cyclically

From lowest to highest and stop to the end: shift from low to high.

From highest to lowest and stop to the begin: shift from high to low.

From lowest to highest and cyclically: once to the end value, shift direction starts over again and constantly cycling from low to high operation.

From highest to lowest and cyclically: once to the start value, shift direction starts over again and constantly cycling from high to low operation.

Parameter "Reset function"

This parameter is for setting whether to enable shift reset function. Options:

Disable**Enable by long operation**

Disable: not possible to reset shift.

Enable by long operation: possible to reset shift by long operation, when reset, shift will start new.

5.4.1.10. Multiple operation

Function of Channel	Multiple operation
Description (Valid display space is up to 18 small chars, while 6 Chinese chars)	
Object type for object1	1Bit_On/Off
Function of short operation	TOGGLE
Function of long operation	TOGGLE
<hr/>	
Object type for object2	1Bit_On/Off
Function of short operation	TOGGLE
Function of long operation	No reaction
<hr/>	
Object type for object3	1Bit_On/Off
Function of short operation	TOGGLE
Function of long operation	No reaction
<hr/>	
Object type for object4	1Bit_On/Off
Function of short operation	TOGGLE
Function of long operation	No reaction

Fig.5.4.1.10 Multiple operation

Parameter "Object type for object x" (x=1~4)

This parameter is for setting the datatype when long/short operation to send. Options:

- Disable**
- 1Bit_On/Off**
- 1Bit_Up/Down**
- 1Byte_RecallScene**
- 1Byte_StoreScene**
- 1Byte_Percentage**

1Byte_Unsigned value

14Byte_String

Note: only object 1 and short operation support to send 14byte string.

——Parameter "Function of short operation"

——Parameter "Function of long operation"

These two parameters are for setting the specific values to send when perform the operation, either no action or sending value.

When "1Bit_On/Off" is selected, options:

No reaction

OFF

ON

TOGGLE

When "1Bit_Up/Down" is selected, options:

No reaction

Up

Down

Up/Down

When "1byte..." or "14Byte_String" is selected, options:

No reaction

Send Value

——Parameter "Value x..." (x=1~2)

This parameter is visible when "1byte..." is selected and previous parameter is selected "Send Value". Set sending values when perform operations. The range of value is up to the datatype selected by the parameter before last one.

——Parameter "String (10byte) value"

This parameter is visible when "14Byte_String" is selected and previous parameter is selected "Send Value". Set sending string when perform operations, up to input 10 characters.

5.4.1.11.Delay mode

Function of Channel	Delay mode
Description (Valid display space is up to 18 small chars,while 6 Chinese chars)	
Object type for short operation	1Bit_On/Off
Send mode	No action when operation,delay then send value1
Delay time [1..6500]	10 s
Value 1	<input checked="" type="radio"/> OFF <input type="radio"/> ON
Value 2	<input type="radio"/> OFF <input checked="" type="radio"/> ON
Object type for long operation	1Bit_On/Off
Send mode	No action when operation,delay then send value1
Delay time [1..6500]	10 s
Value 1	<input checked="" type="radio"/> OFF <input type="radio"/> ON
Value 2	<input type="radio"/> OFF <input checked="" type="radio"/> ON

Fig.5.4.1.11 Delay mode

Parameter "Object type for short operation"

Parameter "Object type for long operation"

These two parameters are for setting the datatype when long/short operation to send. Options:

- Disable**
- 1Bit_On/Off**
- 4Bit_Dimming**
- 1Byte_Unsigned value**

These three parameters as follow are not visible when "Disable" is selected:

Parameter "Send mode"

This parameter is for setting the send mode. Options:

- No action when operation,delay then send value1**

No action when operation, delay then send value2

Send value1 when operation, delay then send value2

Send value2 when operation, delay then send value1

——Parameter "Delay time [1..6500]s"

This parameter is for setting the delay time. Options: **1..6500 s**

——Parameter "Value x" (x=1~2)

This parameter is for setting the value 1/2 to send. The range of value is up to the datatype selected by the parameters.

5.4.1.12. Status display

Function of Channel	Status display
Description (Valid display space is up to 18 small chars, while 6 Chinese chars)	
Display function	Int. temperature
Text for unit	°C
Disable function	Disable=1/Enable=0
Lock Icon indicated when disabled	<input checked="" type="radio"/> Small icon <input type="radio"/> Big icon

Fig.5.4.1.12 Status display

Parameter "Display function"

This parameter is for setting the object datatype for status display function. Options:

Int. temperature

Int. humidity

Ext. temperature

Ext. humidity

1bit value

1byte percent value

1byte unsigned value

2byte unsigned value

2byte float value

4byte unsigned value

4byte float value

14byte string

—Parameter "Text for unit"

This parameter is visible when "Int. temperature", "Int. humidity", "Ext. temperature", "Ext. humidity", "1byte percent value", "1byte unsigned value", "2byte unsigned value", "2byte float value", "4byte

unsigned value”, “4byte float value” are selected. Set the text for display unit.

—Parameter“Status text for 1-ON”

—Parameter“Status text for 1-OFF”

This parameter is visible when “1bit value”is selected. Set the status text for ON and OFF.

—Parameter“Decimal place”

This parameter is visible when “2byte float value”, “4byte float value” are selected. Set the decimal place.

Parameter“Time period for request external value [0..255]”

This parameter is for setting the time period for device to send a control value read request to external after bus recovery or finish programming. Options: **0..255**

Note: Data of this device and 14byte string does not support to be requested.

5.4.1.13.RGB dimming

Function of Channel RGB dimming ▾

Description (Valid display space is up to 18 small chars,while 6 Chinese chars) []

Reaction on short operation Switch toggle

Reaction on long operation Enter into the sub dimming page

Sub dimming page preview



Button 1	press to decrease H value	Button 2	press to increase H value
Button 3	press to decrease S value	Button 4	press to increase S value
Button 5	press to decrease V value	Button 6	press to increase V value
Button 7	NA	Button 8	NA

Object datatype
 1x3byte 3x1byte(HSV)

Reaction on "off" operation
 Only switch object send value 0
 Brightness objects send value 0

Reaction on "on" operation
 Only switch object send value 1
 Preset colour brightness value

RGB value #FFFFFF 

Step of H (hue) 30 ▾ °

Step of S (saturation) 10 ▾ %

Step of V (value) 10 ▾ %

Fig.5.4.1.13 RGB dimming

Parameter "Reaction on short operation"

Parameter "Reaction on long operation"

These two parameters are for explaining the reaction on short/long operation. Short operation default to switch between on and off, and long operation is to enter the sub dimming page.

Display sub dimming page preview and the button operations below these parameters.

Parameter "Object datatype"

This parameter is for setting the object datatype of RGB dimming. Option:

1x3byte

3x1byte(HSV)

Parameter "Reaction on "off" operation"

This parameter is for setting the sent telegram when "off" operation, you can choose only switch object send value 0, or the brightness objects send value 0. Options:

Only switch object send value 0

Brightness objects send value 0

Parameter "Reaction on "on" operation"

This parameter is for setting the sent telegram when "on" operation, you can choose only switch object send value 1, or the colour brightness objects send presetting value. Options:

Only switch object send value 1

Preset colour brightness value

——Parameter "RGB value"

This parameter is visible when "Preset colour brightness value" is selected. Set the sending RGB value. Options: **#000000#FFFFFF**

——Parameter "Step of H (hue)"

This parameter is for setting the step value of Hue. Options:

10°

...

40°**60°****——Parameter "Step of S (saturation)"**

This parameter is for setting the step value of Saturation. Options:

5%**10%****20%****——Parameter "Step of V (value)"**

This parameter is for setting the step value of Value. Options:

5%**10%****20%**

5.4.1.14.RGBW dimming

Function of Channel RGBW dimming ▾

Description (Valid display space is up to 18 small chars,while 6 Chinese chars) []

Reaction on short operation Switch toggle

Reaction on long operation Enter into the sub dimming page

Sub dimming page preview

Button 1	press to decrease H value	Button 2	press to increase H value
Button 3	press to decrease S value	Button 4	press to increase S value
Button 5	press to decrease V value	Button 6	press to increase V value
Button 7	press to decrease W value	Button 8	press to increase W value

Object datatype 1x6byte ▾

Reaction on "off" operation

Only switch object send value 0
 Brightness objects send value 0

Reaction on "on" operation

Only switch object send value 1
 Preset colour brightness value

Step of H (hue) 30 ▾ °

Step of S (saturation) 10 ▾ %

Step of V (value) 10 ▾ %

Step of W(white brightness) 10 ▾ %

Fig.5.4.1.14 RGBW dimming

Parameter "Reaction on short operation"**Parameter "Reaction on long operation"**

These two parameters are for explaining the reaction on short/long operation. Short operation default to switch between on and off, and long operation is to enter the sub dimming page.

Display sub dimming page preview and the button operations below these parameters.

Parameter "Object datatype"

This parameter is for setting the object datatype of RGBW dimming. Options:

1x6byte

4x1byte (RGBW)

4x1byte(HSVW)

Parameter "Reaction on "off" operation"

This parameter is for setting the sent telegram when "off" operation, you can choose only switch object send value 0, or the brightness objects send value 0. Options:

Only switch object send value 0

Brightness objects send value 0

Parameter "Reaction on "on" operation"

This parameter is for setting the sent telegram when "on" operation, you can choose only switch object send value 1, or the colour brightness objects send presetting value. Options:

Only switch object send value 1

Preset colour brightness value

——Parameter "RGB value"

This parameter is visible when "Preset colour brightness value" is selected. Set the sending RGB value. Options: #000000#FFFFFF

——Parameter "White brightness value"

This parameter is visible when "Preset colour brightness value" is selected. Set the sending white brightness value. Options: 0..100%

Parameter "Step of H (hue)"

This parameter is for setting the step value of Hue. Options:

10°

...

40°

60°

Parameter "Step of S (saturation)"

This parameter is for setting the step value of Saturation. Options:

5%

10%

20%

Parameter "Step of V (value)"

This parameter is for setting the step value of Value. Options:

5%

10%

20%

Parameter "Step of W (white brightness)"

This parameter is for setting the step value of white brightness. Options:

5%

10%

20%

5.4.1.15. Colour temperature dimming

Function of Channel Colour temperature dimming ▾

Description (Valid display space is up to 18 small chars, while 6 Chinese chars) []

Reaction on short operation Switch toggle

Reaction on long operation Enter into the sub dimming page

Sub dimming page preview



Button 1	press to decrease colour temperature	Button 2	press to increase colour temperature
Button 3	press to decrease brightness	Button 4	press to increase brightness
Button 5	NA	Button 6	NA
Button 7	NA	Button 8	NA

Object datatype of colour temperature
 1byte relative percentage value
 2byte absolute value

Reaction on "off" operation
 Only switch object send value 0
 Brightness objects send value 0

Reaction on "on" operation Only switch object send value 1 ▾

Min. colour temperature [2000..7000] 2700 ▴ ▾ K

Max. colour temperature [2000..7000] 6500 ▴ ▾ K

Step of colour temperature 500 ▾ K

Step of brightness 10 ▾ %

Fig.5.4.1.15 Colour temperature dimming

Parameter "Reaction on short operation"**Parameter "Reaction on long operation"**

These two parameters are for explaining the reaction on short/long operation. Short operation default to switch between on and off, and long operation is to enter the sub dimming page.

Display sub dimming page preview and the button operations below these parameters.

Parameter "Object datatype of colour temperature"

This parameter is for setting the object datatype of colour temperature dimming. Options:

1byte relative percentage value

2byte absolute value

When "1byte relative percentage value" is selected, it applies to the products of colour temperature with 0/1-10V drive. Control telegram is percentage type, and the step value is set via ETS, show the absolute colour temperature on the screen instead of percent value. Telegram range is 0~100%.

While "2byte absolute value" is selected, it applies to the products that support KNX colour temperature. Control telegram is absolute colour temperature type, and the step value is set via ETS, show directly the absolute colour temperature on the screen. Telegram range is depend on the configuration of Max./Min. parameters.

Parameter "Reaction on "off" operation"

This parameter is for setting the sent telegram when "off" operation, you can choose only switch object send value 0, or the brightness objects send value 0. Options:

Only switch object send value 0

Brightness objects send value 0

Parameter "Reaction on "on" operation"

This parameter is for setting the sent telegram when "on" operation, you can choose only switch object send value 1, or the colour brightness objects send presetting value. Options:

Only switch object send value 1

Preset brightness value

Preset brightness value+Colour temperature

—Parameter“Brightness is”

This parameter is not visible when “Only switch object send value 1” is selected. Set the sending brightness value.

Options: **0..100%**

—Parameter“Colour temperature is”

This parameter is visible when “Preset brightness value+Colour temperature” is selected. Set the sending colour temperature value.

Options: **2000..7000K**

—Parameter“Min. colour temperature [2000..7000]”

—Parameter“Max. colour temperature [2000..7000]”

These two parameters are for setting the adjustable range of colour temperature.

Options: **2000..7000K**

For colour temperature, the Min. value must less than the Max., if not, if not, they can not be modified on ETS, and display red box warning, as shown as follow:

Min. colour temperature [2000..7000]	6500	↕	K
Max. colour temperature [2000..7000]	6500	↕	K

—Parameter“Step of colour temperature”

This parameter is for setting the step value of colour temperature. Options:

100K

200K

500K

1000K

Parameter "Step of brightness"

This parameter is for setting the step value of brightness. Options:

- 5%
- 10%
- 20%

5.4.1.16. Colour temperature adjustment

Function of Channel	Colour temperature adjustment	▼
Description (Valid display space is up to 18 small chars, while 6 Chinese chars)	<input type="text"/>	
Reaction on short operation	TOGGLE	▼
Reaction on long operation	Increase/Decrease colour temperature	▼
Initial value when no response in startup	4000	▲▼ K
Min. colour temperature [2000..7000]	2700	▲▼ K
Max. colour temperature [2000..7000]	6500	▲▼ K
Step of colour temperature	500	▼ K
Interval of tele. cyclic send [0..25,0=send once]	0	▲▼ *0.1s

Fig.5.4.1.16 Colour temperature adjustment

Parameter "Reaction on short operation"

This parameter is for setting the performed action when short operation. Options:

- No reaction
- OFF
- ON
- TOGGLE

Parameter "Reaction on long operation"

This parameter is for setting the performed action when long operation, it is absolute adjustment of 2byte. Options:

Increase colour temperature

Decrease colour temperature

Increase/Decrease colour temperature

Parameter "Initial value when no response in startup"

This parameter is for setting the initial value when no response in startup. Options: **2000..7000K**

Parameter "Min. colour temperature [2000..7000]"

Parameter "Max. colour temperature [2000..7000]"

These two parameters are for setting the adjustable range of colour temperature.

Options: **2000..7000K**

When "Increase colour temperature" is selected for long operation, only allow to set the Max. colour temperature; while "Decrease colour temperature" is selected, only allow to set the Min. colour temperature.

Parameter "Step of colour temperature"

This parameter is for setting the step value of colour temperature. Options:

100K

200K

500K

1000K

Parameter "Interval of tele. cyclic send [0..25,0=send once]"

This parameter is visible when the dimming way is selected "Step dimming". Set intervals of telegram cyclically sending dimming telegram. Options: **0..25*0.1s, 0=send once**

5.4.2. Status indication of individual button

Status display indication	Via button switch status object ▼
Indication type	Icon + Description of button ▼
Icon for object value=1	☀ Light on ▼
Colour for object value=1	Orange ▼
Icon for object value=0	🚫 Light off ▼
Colour for object value=0	Foreground ▼

Via button switch status object

Status display indication	Via external status object 1 bit ▼
Indication type	Icon + Description of button ▼
Icon for object value=1	☀ Light on ▼
Colour for object value=1	Orange ▼
Icon for object value=0	🚫 Light off ▼
Colour for object value=0	Foreground ▼

Via external status object 1 bit

Status display indication	Via external status object 1 byte
Indication type	Icon + Description of button
Object datatype	<input type="radio"/> 1byte[0..255] <input checked="" type="radio"/> 1byte[0..100%]
Threshold compare type	<input checked="" type="radio"/> Between the threshold value <input type="radio"/> Equal to the threshold value
Number of threshold	1
Threshold value 1 is	0 %
Initial icon is	Light on
Initial colour is	Foreground
If object value <= threshold value 1	
Icon is	Light on
Colour is	Foreground
If object value > threshold value 1	
Icon is	Light on
Colour is	Red
	Via external status object 1 byte
Status display indication	Always
Indication type	Icon + Description of button
Icon for indication	Light on
Colour for indication	Foreground
	Always

Fig.5.6.2 Status indication of individual button

Parameter "Status display indication"

This parameter is for setting the status indication of button.

When button with switch function, including switch, dimming, RGB switching/send value, RGB switching/send value, colour temperature switching/send value, RGB dimming, RGBW dimming, colour temperature dimming, colour temperature adjustment. Options:

Via button switch status object

Via external status object 1 bit

Via external status object 1 byte

Always

When button without switch function, including value sender, scene control, blind, shift register, multiple operation, delay mode. Options:

Via external status object 1 bit

Via external status object 1 byte

Always

Via external status object 1 bit: indicate the status via the value feed back form the 1 bit external object;

Via external status object 1 byte: indicate the status via comparing the value feed back form the 1 byte external object to the threshold value;

Always: always indicate in the same status.

Parameter "Indication type"

This parameter is for setting the indication type of button.

When you select the function: switch,dimming, RGB switching/send value, RGB switching/send value, colour temperature switching/send value, value sender, scene control, blind, shift register, multiple operation, delay mode, RTC operation mode, RGB dimming, RGBW dimming or colour temperature dimming. Options:

Description of button

Icon only

Icon + Description of button

The description of button is configured via the parameter "Description (Valid display space is up to 18 small chars,while 6 Chinese chars)".

Parameters as follow are visible when status indication is selected “Via button switch status object” or “External status object 1 bit”:

Parameter “Icon for object value=1”

Parameter “Icon for object value=0”

These two parameters are visible when indication type is selected “Icon...”. Set the icon for object value=1 or value =0. Options:

Light on

Light off

...

Power meter

The icons corresponding to the options are described in the appendix, please refer to chapter 7.

Parameter “Colour for object value=1”

Parameter “Colour for object value=0”

These two parameters are for setting the colour of icon and text when status object telegram value is 1 or 0. Options:

Foreground

Red

Dark green

Blue

Yellow

Orange

Purple

Grey

Pink

Cyan blue

Cyan

Coffee

Light orange

Customized colour 1

Customized colour 2

Customized colour 3

Customized colour 4

Customized colour 5

Parameters as follow are visible when status indication is selected "Via external status object 1 byte":

Parameter "Object datatype"

This parameter is for setting the object datatype of status indication. Options:

1byte[0..255]

1byte[0..100%]

Parameter "Threshold compare type"

This parameter is for setting the threshold compare type, you can select to display when between the threshold value, or equal to the threshold value. Options:

Between the threshold value

Equal to the threshold value

Parameter "Number of threshold"

This parameter is for setting the number of threshold compare.

When "Between the threshold value" is selected, options: **1 / 2 / 3 / 4**

When "Equal to the threshold value" is selected, options: **1 / 2 / 3 / 4 / 5**

Parameter "Threshold value x is" (x=1-5)

This parameter is for setting threshold value, status indication is via comparing between input value and threshold value.

Options display according to the object datatype: **0..255 / 0..100%**

Parameter "Initial icon is"

This parameter sets the icon displayed initially and when the threshold is not met. Options:

Light on

Light off

...

Power meter

The icons corresponding to the options are described in the appendix, please refer to chapter 7.

Parameter "Initial colour is"

This parameter sets the colour displayed initially and when the threshold is not met.

Options:

Foreground	Cyan blue
Red	Cyan
Dark green	Coffee
Blue	Light orange
Yellow	Customized colour 1
Orange	Customized colour 2
Purple	Customized colour 3
Grey	Customized colour 4
Pink	Customized colour 5

Parameter "If object value <= threshold value x" (x=1~4)

Parameter "If object value > threshold value x" (x=1~4)

Parameter "If object value = threshold value x" (x=1~5)

According to the threshold compare type and the number of threshold compare, you can set the icon and colour to display which match the threshold compare. Parameters as follow:

—Parameter "Icon is"

This parameter is visible when indication type is selected "Icon...". Set the icon to display which matches the threshold compare. Options:

Light on

Light off

...

Power meter

The icons corresponding to the options are described in the appendix, please refer to chapter 7.

—Parameter“Colour is”

This parameter is for setting the colour of icon and text which matches the threshold compare.

Options:

Foreground	Cyan blue
Red	Cyan
Dark green	Coffee
Blue	Light orange
Yellow	Customized colour 1
Orange	Customized colour 2
Purple	Customized colour 3
Grey	Customized colour 4
Pink	Customized colour 5

Parameters as follow are visible when status indication is selected “Always”:

Parameter“Icon for indication”

This parameter is visible when indication type is selected “Icon...”. Set the icon to display for status indication. Options:

Light on

Light off

...

Power meter

The icons corresponding to the options are described in the appendix, please refer to chapter 7.

Parameter“Colour for indication”

This parameter is for setting the colour for status indication. Options:

Foreground**Cyan blue****Red****Cyan****Dark green****Coffee****Blue****Light orange****Yellow****Customized colour 1****Orange****Customized colour 2****Purple****Customized colour 3****Grey****Customized colour 4****Pink****Customized colour 5**

5.4.3.Rocker button

5.4.3.1.Switch

Function of Channel	Switch
Description (Valid display space is up to 18 small chars,while 6 Chinese chars)	
Distinction between short and long operation	<input type="checkbox"/>
Reaction on press operation (for left of rocker)	TOGGLE
Reaction on release operation (for left of rocker)	TOGGLE
Reaction on press operation (for right of rocker)	TOGGLE
Reaction on release operation (for right of rocker)	TOGGLE
Number of objects	<input checked="" type="radio"/> 1 <input type="radio"/> 2
Disable function	Disable=1/Enable=0
Lock Icon indicated when disabled	<input checked="" type="radio"/> Small icon <input type="radio"/> Big icon
Flashing function	Disable=1/Enable=0
Colour for flashing	Red

Fig.5.4.3.1 Switch

Parameter "Description (Valid display space is up to 18 small chars,while 6 Chinese chars)"

This parameter is for setting the description of rocker button, up to input 18 characters.

Note: The valid display space on the screen is up to 18 small chars, while 6 Chinese chars and supports newline display.

Parameter "Distinction between short and long operation"

This parameter is for setting whether to distinction the contact operation between short and long operation.

Parameter "Reaction on short/press operation (for left/right of rocker)"

Parameter "Reaction on long/release operation (for left/right of rocker)"

These parameters are for setting the performed actions for left/right of rocker buttons when press/release the contact or long/short operation. The object value is updated when the input is determined. Options:

No reaction

OFF

ON

TOGGLE

No action: no telegram to be sent.

ON: send on telegram.

OFF: send off telegram.

TOGGLE: each operation will toggle the switch between on and off. For example, if send an On telegram(or received) at the last, then the next operation will trigger an Off telegram. When the contact is operated again, it will send an On telegram, etc. So the contact will always remember the previous status and covert to opposite value during next operation. When the device is powered on for the first time or restarted after downloading, the default value for "Switch" is 0, meaning the first operation is ON.

Parameter "Number of objects"

This parameter is visible when the parameters "Reaction on short/press operation(for left/right of rocker)" or "Reaction on long/release operation(for left/right of rocker)" are not selected "No reaction".

Set the number of objects when short/long or press/release operation. Options:

1

2

Parameter "Disable function"

This parameter is for setting trigger value to disable/enable contacts. Options:

Disable

Disable=1/Enable=0

Disable=0/Enable=1

—Parameter “Lock Icon indicated when disabled”

This parameter is not visible when “Disable” is selected. Set the icon size when the button is in disable status. Options:

Small icon

Big icon

Big icon is the lock icon replaces the original icon, e.g. ; while small icon is the two icons

coexist and the lock icon is a small icon in right corner, e.g. .

Parameter “Flashing function”

This parameter is for setting whether to enable flashing function. Options:

Disable

Disable=1/Enable=0

Disable=0/Enable=1

—Parameter “Colour for flashing”

This parameter is not visible when previous parameter is selected “Disable”. Set the colour for flashing. Options:

Foreground

Cyan blue

Red

Cyan

Dark green

Coffee

Blue

Light orange

Yellow

Customized colour 1

Orange**Customized colour 2****Purple****Customized colour 3****Grey****Customized colour 4****Pink****Customized colour 5**

Note: flashing function is only used for “Switch”, “Dimming” and “Blind”.

Function display priority: Lock function >Flashing function > Normal status indication.

If flashing function and lock function are both triggered at the same time, it will interrupt flashing and the flashing can be resumed only after it is unlocked, cancel flashing then return to the normal status indication.

When enabled flashing function, flashing function is only applied to middle field, and the left/right field will not flash when flashing function enabled.

Repeat parameters will not be illustrated below; the usage is similar.

5.4.3.2. Dimming

Function of Channel	Dimming
Description (Valid display space is up to 18 small chars, while 6 Chinese chars)	
Reaction on short operation (for left of rocker)	ON
Reaction on long operation (for left of rocker)	Brighter
Reaction on short operation (for right of rocker)	OFF
Reaction on long operation (for right of rocker)	Darker
Dimming mode	<input type="radio"/> Start-Stop dimming <input checked="" type="radio"/> Step dimming
Step size	12.5 %
Interval of tele. cyclic send [0..25,0=send once]	0 *0.1s

Fig.5.4.3.2 Dimming

Parameter "Reaction on short operation (for left/right of rocker)"

These two parameters are for setting the sending switch value for left/right of rocker buttons when short operation. Options:

No reaction

OFF

ON

TOGGLE

No action: no telegram to be sent.

ON: send on telegram.

OFF: send off telegram.

TOGGLE: each operation will toggle the switch between on and off. When the device is powered on for the first time or restarted after downloading, the default value for "Switch" is 0, meaning the first operation is ON.

Parameter "Reaction on long operation (for left/right of rocker)"

These two parameters are for setting the sending relative dimming value for left/right of rocker buttons when long operation, with dimming brighter or darker; when release the contact stop dimming.

Options:

No reaction

Brighter

Darker

Brighter/Darker

No action: no telegram to be sent.

Brighter: send the dimming up value.

Darker: send the dimming down value.

Brighter/darker: each operation will toggle the dimming between up and down. When the device is powered on for the first time or restarted after downloading, the default value for "Dimming" is 0, meaning the first operation is dim up the brightness.

Note: In the options of "TOGGLE" and "Brighter/Darker", there are a linkage between the received switch status and the dimming. For example, if receive an On value from object "Switch" at the last, then it will dim down the brightness in next dimming operation. If receive an Off value first, then it will dim up the brightness in next dimming operation.

Parameter "Dimming mode"

This parameter is for setting the way of relative dimming. Options:

Start-Stop dimming

Step dimming

Start-stop dimming: the dimming mode will be start-stop, a dimming up or down telegram will be sent when the dimming starts, and a stop telegram will be sent when dimming ends. Here the dimming telegram will not be sent cyclically.

Steps dimming: the dimming mode will be a step one and the dimming telegram will be sent

cyclically. When dimming ends, a stop dimming telegram will be sent immediately.

—Parameter“ Step size”

This parameter is visible when the dimming way is selected “Step dimming”. Set a cyclically sending dimming telegram which changes the brightness percentage.

Options:

100%

50%

...

1.56%

—Parameter“ Interval of tele. cyclic send [0..25,0=send once]”

This parameter is visible when the dimming way is selected “Step dimming”. Set intervals of telegram cyclically sending dimming telegram. Options: **0..25*0.1s, 0=send once**

5.4.3.3. Scene control

Function of Channel	Scene control ▼
Description (Valid display space is up to 18 small chars, while 6 Chinese chars)	<input type="text"/>
Reaction on short operation (for left of rocker)	Recall scene ▼
8 bit scene number	Scene No.1 ▼
Reaction on long operation (for left of rocker)	Store scene ▼
8 bit scene number	Scene No.1 ▼
Reaction on short operation (for right of rocker)	Recall scene ▼
8 bit scene number	Scene No.2 ▼
Reaction on long operation (for right of rocker)	Store scene ▼
8 bit scene number	Scene No.2 ▼
Number of objects	<input checked="" type="radio"/> 1 <input type="radio"/> 2

Fig.5.4.3.3 Scene control

Parameter "Reaction on short operation (for left/right of rocker)"

Parameter "Reaction on long operation (for left/right of rocker)"

These two parameters are for setting to recall or storage scene for left/right of rocker buttons when long/short operation. Options:

No reaction

Recall scene

Store scene

Parameters as follow are visible when "Reaction on short operation" or "Reaction on long operation" are not selected "No reaction":

—Parameter "8 bit scene number"

This parameter is for setting the scene number. Options:

Scene NO.1

Scene NO.2

Scene NO.3

...

Scene NO.64

Corresponding telegram is 0~63.

——**Parameter“Number of objects”**

This parameter is for setting the number of objects when short/long operation. Options:

1

2

5.4.3.4.Blind

Function of Channel	Blind
Description (Valid display space is up to 18 small chars,while 6 Chinese chars)	
Reaction on short operation (for left of rocker)	Stop(Adjust Up)
Reaction on long operation (for left of rocker)	Up
Reaction on short operation (for right of rocker)	Stop(Adjust Down)
Reaction on long operation (for right of rocker)	Down

Fig.5.4.3.4 Blind

Parameter "Reaction on short operation (for left/right of rocker)"

Parameter "Reaction on long operation (for left/right of rocker)"

These parameters are for setting the performed actions for left/right of rocker buttons when long/short operation. The object value is updated when the input is determined. Options:

No reaction

Up

Down

Up/Down

Stop(Adjust Up)

Stop(Adjust Down)

Stop(Adjust Up/Down)

No action: no telegram to be sent.

Up: the blinds will be opened or moved up.

Down: the blinds will be closed or moved down.

Up/Down: alternately open/close or move up/down the blinds. When the device is powered on for the first time or restarted after downloading, the default value for "Up/Down, Blind" is 0, meaning the first operation is closing or moving down the blinds.

Stop (Adjust Up): stop the blind movement or move up the angle of blinds.

Stop (Adjust Down): stop the blind movement or move down the angle of blinds.

Stop (Adjust Up/Down): stop the blind movement or move up/down the angle of blinds alternately.

When the device is powered on for the first time or restarted after downloading, the default value for "Stop/Adjust Blind" is 0, meaning the first operation is stop or move down the angle of blinds.

—Parameter "Interval of tele. cyclic send [0..25,0=send once]"

This parameter is for setting the time interval of cyclical blinds angle adjustment telegram sent.

Options: **0..25*0.1s,0=send once**

5.4.3.5.Setpoint adjustment

Function of Channel	Setpoint adjustment
Description (Valid display space is up to 18 small chars,while 6 Chinese chars)	
Function	Setpoint adjustment(absolute)
Reaction on operation	<input checked="" type="radio"/> First to display setpoint <input type="radio"/> First to execute command & display setpoint
Rocker operation mode	<input type="radio"/> Increase/Decrease <input checked="" type="radio"/> Decrease/Increase
Setpoint adjustment step	<input checked="" type="radio"/> 0.5K <input type="radio"/> 1K
Initial value when no response in startup	20 °C
Min. setpoint temperature	19 °C
Max. setpoint temperature	26 °C

Fig.5.4.3.5 Setpoint adjustment

Parameter "Function"

This parameter is for setting the adjustment type of setpoint temperature. Options:

Setpoint adjustment(absolute)

Offset Increase/Decrease(relative)

Offset setpoint adjustment(relative)

Setpoint adjustment(absolute): apply to absolute adjust the setpoint temperature.

Offset Increase/Decrease(relative): apply to relative adjust the offset of setpoint temperature via 1 bit object.

Offset setpoint adjustment(relative): apply to relative adjust the offset of setpoint temperature.

Parameter "Reaction on operation"

This parameter is for setting whether only display setpoint temperature when first operate the button, or execute the command at the same time. Options:

First to display setpoint

First to execute command & display setpoint

Parameter "Rocker operation mode"

This parameter is for setting the operation mode of rocker button. Options:

Increase/Decrease

Decrease/Increase

Increase/Decrease: the left of rocker button to increase setpoint temperature, and the right to decrease setpoint temperature.

Decrease/Increase: the left of rocker button to decrease setpoint temperature, and the right to increase setpoint temperature.

Parameter "Setpoint adjustment step"

This parameter is visible when the setpoint temperature adjustment is selected "Setpoint adjustment (absolute)" or "Offset setpoint adjustment (relative)". Set the step value of setpoint adjustment. Options:

0.5K

1K

For absolute adjustment, if current setpoint temperature is 21°C, increase 0.5°C, then the current setpoint temperature is change to 21.5°C and sent to the bus; while decrease 0.5°C, then the current setpoint temperature is change to 20.5°C and sent to the bus.

For relative adjustment, if step value is 1K, current offset is 0K, increase per time to send 1K offset to the bus, if current offset is -1K, decrease per time to send -2K offset to the bus.

Parameters as follow are visible when the setpoint temperature adjustment is selected "Setpoint adjustment (absolute)":

Parameter "Initial value when no response in startup"

This parameter is for setting the initial value of setpoint temperature after voltage recovery or download completion, that is, the used initial value when no response received in startup. Options:

5°C

6°C

...

37°C

Parameter "Min. setpoint temperature"

Parameter "Max. setpoint temperature"

These two parameters are for setting the adjustable range of the setpoint temperature. Options:

5°C

6°C

...

37°C

If the setpoint temperature beyond the limited range, it will output the limited temperature.

For setpoint temperature, the Min. value must less than the Max., if not, it can not be modified on

ETS.

Parameters as follow are visible when the setpoint temperature adjustment is selected "Offset setpoint adjustment (relative)":

Parameter "Initial value when no response in startup"

This parameter is for setting the initial value of setpoint temperature offset after voltage recovery or download completion, that is, the used initial value when no response received in startup.

Options: **-10..10 K**

Parameter "Min. setpoint offset [-10..0]"

This parameter is for setting the maximum offset when setpoint temperature offset decrease (negative offset). Options: **-10..0 K**

Parameter "Max. setpoint offset [0..10]"

This parameter is for setting the maximum offset when setpoint temperature offset increase (forward offset). Options: **0..10 K**

For the offset, the Min. value and the Max. Value cannot be equal to 0 at the same time, if not, they can not be modified on ETS, and display red box warning, as shown as follow:

Min. setpoint offset [-10..0]	<input style="border: 2px solid red;" type="text" value="0"/>	K
Max. setpoint offset [0..10]	<input type="text" value="0"/>	K

5.4.4. Status indication of rocker button

5.4.4.1. Left/Right field display

Left field display

Indication type: Description only Icon only

Icon:

Colour for indication:

Left field display

Right field display

Indication type: Description only Icon only

Icon:

Colour for indication:

Right field display

Fig.5.4.4.1 Left/Right field display

Parameter "Indication type"

This parameter is for setting the indication type for left/right field of rocker buttons. Options:

Description only

Icon only

——Parameter "Description (Valid display space is up to 18 small chars, while 6 Chinese chars)"

This parameter is for setting the description for for left/right field of rocker buttons, up to input 18 characters.

Note: The valid display space on the screen is up to 18 small chars, while 6 Chinese chars and

supports newline display.

—Parameter“Icon”

This parameter is visible when indication type is selected “Icon only”. Set the icon of status indication. Options:

Light on

Light off

...

Power meter

The icons corresponding to the options are described in the appendix, please refer to chapter 7.

Parameter“Colour for indication”

This parameter is for setting the colour of status indication. Options:

Foreground

Red

Dark green

Blue

Yellow

Orange

Purple

Grey

Pink

Cyan blue

Cyan

Coffee

Light orange

Customized colour 1

Customized colour 2

Customized colour 3

Customized colour 4

Customized colour 5

5.4.4.2. Middle field display

Middle field display

Status display indication	Via button switch status object
Indication type	Icon + Description of button
Icon for object value=1	☀ Light on
Colour for object value=1	Orange
Icon for object value=0	🚫 Light off
Colour for object value=0	Foreground

Via button switch status object

Middle field display

Status display indication	Via external status object 1 bit
Indication type	Icon + Description of button
Icon for object value=1	☀ Light on
Colour for object value=1	Orange
Icon for object value=0	🚫 Light off
Colour for object value=0	Foreground

Via external status object 1bit

Middle field display

Status display indication Via external status object 1 byte

Indication type Icon+status value

Object datatype 1byte[0..255] 1byte[0..100%]

Threshold compare type Between the threshold value
 Equal to the threshold value

Number of threshold 1

Threshold value 1 is 0 %

Initial icon is Light on

Initial colour is Foreground

If object value <= threshold value 1

Icon is Light on

Colour is Foreground

If object value > threshold value 1

Icon is Light on

Colour is Red

Via external status object 1byte

Middle field display

Status display indication Via external status object 2 byte

Indication type Status value Icon+status value

Icon for indication Light on

Colour for indication Foreground

Via external status object 2byte

Middle field display

Status display indication Via external status object 14 byte

Indication type Status value

Colour for indication Foreground

Via external status object 14byte

Disable function	Disable=1/Enable=0
Lock Icon indicated when disabled	<input checked="" type="radio"/> Small icon <input type="radio"/> Big icon
Flashing function	Disable=1/Enable=0
Colour for flashing	Red

Always

Fig.5.4.4.2 Middle field display

数“Status indication”

This parameter is for setting the status indication of button.

When button function is switch, options:

- Via button switch status object**
- Via external status object 1 bit**
- Via external status object 1 byte**
- Via external status object 14 byte**
- Always**

When button function is selected scene control or blind, there is no **Via button switch status object**, **Via external status object 14 byte** in the above options.

When button function is selected dimming, in addition to the above options you can also select **Via external status object 2 byte**.

When button function is selected setpoint adjustment, options:

- Via external status object 1 bit**
- Via external status object 2 byte float**
- Always**

Via button switch status object: indicate the status via the value feed back form the switch status object.

Via external status object 1 bit: indicate the status via the value feed back form the 1 bit external object.

Via external status object 1 byte: indicate the status via comparing the value feed back form the 1

byte external object to the threshold value.

Via external status object 2 byte: display the received integer value, such as colour temperature.

Via external status object 2 byte float: display the received float value, such as temperature.

Via external status object 14 byte: display the received string.

Always: always indicate in the same status.

Parameter "Indication type"

This parameter is for setting the indication type of button. Options:

Description of button

Icon only

Icon + Description of button

Status value

Icon+status value

Status value+Int.temp

When button function is selected switch, when status indication is "Via button switch status object", "Via external status object 1 bit", "Via external status object 1 byte" or "Always", there are no option about status, that is, the options have no "Status value" and "...status value"; while it is "Via external status object 14 byte", only "Status value";

When button function is selected scene control, there are no option about status, that is, the options have no "Status value" and "...status value";

When button function is selected dimming, not support to the option "Int.temp + status value", when status indication is "Via button switch status object", "Via external status object 1 bit" or "Always", there are no option about status, that is, the options have no "Status value" and "...status value"; when it is "Via external status object 2 byte", there are only the options about status; while it is "Via external status object 14 byte", only "Status value";

When button function is selected blind, not support to the option "Int.temp + status value", when status indication is "Via button switch status object", "Via external status object 1 bit" or "Always", there are no option about status, that is, the options have no "Status value" and "...status value";

When button function is selected setpoint adjustment, there are no option about status when

status indication is selected “Via external status object 1 bit” or “Always”, that is, the options have no “Status value” and “...status value”; While “Via external status object 2 byte float” is selected, only support to the options about status.

Parameters as follow are visible when status indication is selected “Via button switch status object” or “External status object 1 bit”:

Parameter “Icon for object value=1”

Parameter “Icon for object value=0”

These two parameters are visible when indication type is selected “Icon...”. Set the icon for object value=1 or value =0. Options:

Light on

Light off

...

Power meter

The icons corresponding to the options are described in the appendix, please refer to chapter 7.

Parameter “Colour for object value=1”

Parameter “Colour for object value=0”

These two parameters are for setting the colour of icon and text when status object telegram value is 1 or 0. Options:

Foreground

Cyan blue

Red

Cyan

Dark green

Coffee

Blue

Light orange

Yellow

Customized colour 1

Orange

Customized colour 2

Purple	Customized colour 3
Grey	Customized colour 4
Pink	Customized colour 5

Parameters as follow are visible when status indication is selected "Via external status object 1 byte":

Parameter "Object datatype"

This parameter is for setting the object datatype of status indication. Options:

1byte[0..255]

1byte[0..100%]

Parameter "Threshold compare type"

This parameter is for setting the threshold compare type, you can select to display when between the threshold value, or equal to the threshold value. Options:

Between the threshold value

Equal to the threshold value

Parameter "Threshold compare type"

This parameter is for setting the number of threshold compare.

When "Between the threshold value" is selected, options: **1 / 2 / 3 / 4**

When "Equal to the threshold value" is selected, options: **1 / 2 / 3 / 4 / 5**

Parameter "Threshold value x is" (x=1~5)

This parameter is for setting threshold value, status indication is via comparing between input value and threshold value.

Options display according to the object datatype: **0..255 / 0..100%**

Parameter "Initial icon is"

This parameter sets the icon displayed initially and when the threshold is not met. Options:

Light on

Light off

...

Power meter

The icons corresponding to the options are described in the appendix, please refer to chapter 7.

Parameter "Initial colour is"

This parameter sets the colour displayed initially and when the threshold is not met.

Options:

Foreground	Cyan blue
Red	Cyan
Dark green	Coffee
Blue	Light orange
Yellow	Customized colour 1
Orange	Customized colour 2
Purple	Customized colour 3
Grey	Customized colour 4
Pink	Customized colour 5

Parameter "If object value <= threshold value x" (x=1~4)

Parameter "If object value > threshold value x" (x=1~4)

Parameter "If object value = threshold value x" (x=1~5)

According to the threshold compare type and the number of threshold compare, you can set the icon and colour to display which match the threshold compare. Parameters as follow:

—Parameter "Icon is"

This parameter is visible when indication type is selected "Icon...". Set the icon to display which

matches the threshold compare. Options:

Light on

Light off

...

Power meter

The icons corresponding to the options are described in the appendix, please refer to chapter 7.

—Parameter“Colour is”

This parameter is for setting the colour of icon and text which matches the threshold compare.

Options:

Foreground	Cyan blue
Red	Cyan
Dark green	Coffee
Blue	Light orange
Yellow	Customized colour 1
Orange	Customized colour 2
Purple	Customized colour 3
Grey	Customized colour 4
Pink	Customized colour 5

Parameters as follow are visible when status indication is selected “Via external status object 2 byte float”:

Parameter“Status display unit”

Parameter“Status display unit(Int.temp display unit always °C)”

This parameter is for setting the temperature unit displayed on the screen, and the object datatype

is all DPT 9.001 temperature. Options:

Celsius(°C)

Fahrenheit(°F)

Kelvins(K)

The temperature accuracy is to 0.1 on the screen.

Parameters as follow are visible when status indication is selected “Via external status object 2 byte...” or “Always”:

Parameter “Icon for indication”

This parameter is visible when indication type is selected “Icon...”. Set the icon to display for status indication. Options:

Light on

Light off

...

Power meter

The icons corresponding to the options are described in the appendix, please refer to chapter 7.

Parameter “Colour for indication”

This parameter is for setting the colour for status indication. Options:

Foreground

Red

Dark green

Blue

Yellow

Orange

Purple

Cyan blue

Cyan

Coffee

Light orange

Customized colour 1

Customized colour 2

Customized colour 3

Grey**Customized colour 4****Pink****Customized colour 5**

Parameters as follow are visible when status indication is selected “Via external status object 14 byte”:

Parameter “Colour for indication”

This parameter is for setting the colour for status indication. Options:

Foreground**Cyan blue****Red****Cyan****Dark green****Coffee****Blue****Light orange****Yellow****Customized colour 1****Orange****Customized colour 2****Purple****Customized colour 3****Grey****Customized colour 4****Pink****Customized colour 5**

5.4.5. Status LED indication

Status LED indication	Via button switch status object
Colour for object value=0	OFF
Colour for object value=1	OFF

Via button switch status object

Status LED indication	Via external status object 1 bit
Colour for object value=0	OFF
Colour for object value=1	OFF

Via external status object 1 bit

Status LED indication	Via external status object 1 byte
Object datatype	<input type="radio"/> 1byte[0..255] <input checked="" type="radio"/> 1byte[0..100%]
Threshold compare type	<input checked="" type="radio"/> Between the threshold value <input type="radio"/> Equal to the threshold value
Number of threshold	1
Threshold value 1 is	0 %
Initial colour is	OFF

If object value <= threshold value 1

Colour is	Red
-----------	-----

If object value > threshold value 1

Colour is	Dark green
-----------	------------

Via external status object 1 byte

Status LED indication	Always
LED indication colour	Red

Always

Status LED indication	Indicate button press
When press the button, indicator is	<input checked="" type="radio"/> On <input type="radio"/> Flashing
On duration time is	1s
LED indication colour	Red
Status LED indication	Indicate button press
	Same as Status display indication
	Same as display indication

Fig.5.4.5 Status LED indication

Parameter "Status LED indication"

This parameter is for setting the status LED indication of button.

When button with switch function, including switch, dimming, RGB switching/send value, RGBW switching/send value, colour temperature switching/send value, RGB dimming, RGBW dimming, colour temperature dimming, colour temperature adjustment. Options:

- Disable**
- Via button switch status object**
- Via external status object 1 bit**
- Via external status object 1 byte**
- Always**
- Indicate button press**
- Same as Status display indication**

When button without switch function, including value sender, scene control, blind, shift register, multiple operation, delay mode. Options:

- Disable**
- Via external status object 1 bit**
- Via external status object 1 byte**
- Always**
- Indicate button press**

Same as Status display indication

Via button switch status object: indicate the status via the value feed back form the switch status object.

Via external status object 1 bit: indicate the status via the value feed back form the 1 bit external object.

Via external status object 1 byte: indicate the status via comparing the value feed back form the 1 byte external object to the threshold value.

Always: always indicate in the same status.

Indicate button press: flashing twice (0.5s on and 0.5s off) when press button, then return to normal indication, if there is another press during the flashing cycle, not reset the cycle.

Parameters as follow are visible when status LED indication is selected “Via button switch status object” or “External status object 1 bit”:

Parameter “Colour for object value=0”

Parameter “Colour for object value=1”

These two parameters are for setting the colour of LED when status object telegram value is 1 or 0.

Options:

OFF	Cyan blue
Red	Cyan
Dark green	Coffee
Blue	Light orange
Yellow	Customized colour 1
Orange	Customized colour 2
Purple	Customized colour 3
Grey	Customized colour 4
Pink	Customized colour 5

Parameters as follow are visible when status LED indication is selected "Via external status object

1 byte":

Parameter "Object datatype"

This parameter is for setting the object datatype of status LED indication. Options:

1byte[0..255]

1byte[0..100%]

Parameter "Threshold compare type"

This parameter is for setting the threshold compare type, you can select to display when between the threshold value, or equal to the threshold value. Options:

Between the threshold value

Equal to the threshold value

Parameter "Number of threshold"

This parameter is for setting the number of threshold compare.

When "Between the threshold value" is selected, options: **1 / 2 / 3 / 4**

When "Equal to the threshold value" is selected, options: **1 / 2 / 3 / 4 / 5**

Parameter "Threshold value x is" (x=1-5)

This parameter is for setting threshold value, status indication is via comparing between input value and threshold value.

Options display according to the object datatype: **0..255 / 0..100%**

Parameter "Initial colour is"

This parameter sets the LED to displayed which not matches the threshold compare. Options:

OFF

Cyan blue

Red

Cyan

Dark green

Coffee

Blue

Light orange

Yellow	Customized colour 1
Orange	Customized colour 2
Purple	Customized colour 3
Grey	Customized colour 4
Pink	Customized colour 5

Parameter "If object value <= threshold value x" (x=1~4)

Parameter "If object value > threshold value x" (x=1~4)

Parameter "If object value = threshold value x" (x=1~4)

According to the threshold compare type and the number of threshold compare, you can set the LED to display which match the threshold compare. Parameters as follow:

——Parameter "Colour is"

This parameter is for setting the colour of LED which matches the threshold compare.

Options:

OFF	Cyan blue
Red	Cyan
Dark green	Coffee
Blue	Light orange
Yellow	Customized colour 1
Orange	Customized colour 2
Purple	Customized colour 3
Grey	Customized colour 4
Pink	Customized colour 5

Parameters as follow are visible when status LED indication is selected “Always” or “Indicate button press”:

Parameter “LED indication colour”

This parameter is for setting the LED indication colour. Options:

Red	Cyan
Dark green	Coffee
Blue	Light orange
Yellow	Customized colour 1
Orange	Customized colour 2
Purple	Customized colour 3
Grey	Customized colour 4
Pink	Customized colour 5
Cyan blue	

Parameters as follow are visible when status LED indication is selected “Indicate button press”:

Parameter “When press the button, indicator is”

This parameter is for setting the LED indication status when press the button. Options:

On

Flashing

—Parameter “On duration time is”

This parameter is for setting the LED on duration time. Options:

Options: : **500ms/1s/2s/3s**

—Parameter “Flashing period time is”

This parameter is visible when “Flashing” is selected. Set the LED flashing period time.

Options: **0.4s/0.8s/1.2s/1.6s/2.0s**

—Parameter “Normal indication is”

This parameter is visible when “Flashing” is selected. Set the LED normal indication when finish flashing. Options: **OFF/ON**

5.4.6.Slap function

i Trigger method: at least 2 buttons locating in the same side are pressed

Slap function of left buttons	Switch ▼
Description (max 18char.)	<input type="text"/>
Reaction on slap operation	TOGGLE ▼
Slap function of right buttons	Scene control ▼
Description (max 18char.)	<input type="text"/>
Reaction on slap operation	Recall scene ▼
8 bit scene number	Scene No.1 ▼
Disable function	Disable ▼

Fig.5.4.6 Slap function

You can set whether enable slap function when at least 2 buttons locating in the same side are pressed. If enabled, ignore the individual/rocker button function when operation. The slap function of left and right buttons can be configured separately:

Parameter “Slap function of left buttons”

Parameter “Slap function of right buttons”

These parameter are for setting the slap function of left and right buttons. Options:

Disable

Switch

Scene control

Parameter Description (max 18char.)

This parameter is for setting the description of individual button, up to input 18 characters.

—Parameter“Reaction on slap operation”

When “Switch” is selected, set the performed actions when slap operation. The object value is updated when the input is determined. Options:

No reaction

OFF

ON

TOGGLE

No action: no telegram to be sent.

ON: send on telegram.

OFF: send off telegram.

TOGGLE: each operation will toggle the switch between on and off. For example, if send an On telegram(or received) at the last, then the next operation will trigger an Off telegram. When the contact is operated again, it will send an On telegram, etc. So the contact will always remember the previous status and covert to opposite value during next operation. When the device is powered on for the first time or restarted after downloading, the default value for “Switch” is 0, meaning the first operation is ON.

When “Scene control” is selected, set the recall or storage scene when slap operation. Options:

No reaction

Recall scene

Store scene

—Parameter“8 bit scene number”

This parameter is visible when “No reaction” is not selected. Set the scene number. Options:

Scene NO.1

Scene NO.2

Scene NO.3

...

Scene NO.64

Corresponding telegram is 0~63

Parameter "Disable function"

This parameter is for setting trigger value to disable/enable contacts. Options:

Disable

Disable=1/Enable=0

Disable=0/Enable=1

5.4.7. Parameter window "Customized colour"





Customized colour 1	
RGB value	
Customized colour 2	
RGB value	
Customized colour 3	
RGB value	
Customized colour 4	
RGB value	
Customized colour 5	
RGB value	

Fig.5.4.7 Parameter window "Customized colour"

Customized colour x (x=1~5)

Parameter "RGB value"

This parameter is for setting the customized colour of status indication, user up to define 5 colour.

Options: #000000#FFFFFF

5.5. Parameter window "Room temperature controller"

RTC 1	<input checked="" type="checkbox"/>
RTC 2	<input type="checkbox"/>

Fig.5.5 Parameter window "Room temperature controller"

Parameter "RTC x" (x=1, 2)

Function page of RTC is visible after this parameter enabled.

5.5.1. Parameter window "RTC x(x=1,2)"

Description (max 30char.)	<input type="text"/>
Room temperature reference from	Internal sensor <input type="text"/>
Control value after temp. error[0..100] (if 2-point control, set value '0'=0, set value '>0'=1)	0 <input type="text"/> %
<hr/>	
Room temperature control mode	Heating and Cooling <input type="text"/>
Heating/Cooling switchover	<input checked="" type="radio"/> Via object <input type="radio"/> Automatic changeover
Heating/Cooling status after download	<input checked="" type="radio"/> Heating <input type="radio"/> Cooling
Heating/Cooling status after voltage recovery	As before voltage failure <input type="text"/>
Room temperature control system	<input type="radio"/> 2 pipes system <input checked="" type="radio"/> 4 pipes system
<hr/>	
Operation mode	<input checked="" type="checkbox"/>
Controller status after download	Comfort mode <input type="text"/>
Controller status after voltage recovery	As before voltage failure <input type="text"/>
Extended comfort mode [0..255,0=inactive]	0 <input type="text"/> min
1 bit object function for operation mode	<input checked="" type="checkbox"/>
1 bit object for standby mode	<input checked="" type="checkbox"/>
<hr/>	
Fan speed auto.control function	<input checked="" type="checkbox"/>
<hr/>	
Window contact input function	<input checked="" type="checkbox"/>
Delay for window contact [0..65535]	15 <input type="text"/> s
Controller mode for open window	<input type="radio"/> Economy mode <input checked="" type="radio"/> Frost/heat protection
Bus presence detector function	<input type="checkbox"/>

Fig.5.5.1 Parameter window "RTC x(x=1,2)"

Parameter "Description (max 30char.)"

This parameter is for setting the name description for RTC, up to input 30 characters.

Parameter "Room temperature reference from "

This parameter is for setting the resource of the RTC function temperature reference.

Options:

Internal sensor

External sensor

Internal and External sensor combination

When selecting the reference "Internal sensor", the temperature is determined by the setting of the "Internal sensor measurement" in the parameter interface, more details refer to chapter 5.3.

Parameters as follow are visible when "Internal sensor combine with External sensor" is selected:

——**Parameter "Combination ratio"**

This parameter is for setting the internal sensor and the external sensor to measure the specific gravity of the temperature. Options:

10% Internal to 90% External

20% Internal to 80% External

...

80% Internal to 20% External

90% Internal to 10% External

For example, if the option is "40% internal to 60% external", then the internal sensor accounts for 40%, the external sensor accounts for 60%, and the control temperature = (internal sensor's temperature × 40%) + (external sensor's temperature × 60%), the RTC function of the device will control and display the temperature according to the calculated temperature.

When two sensors are combined for detection, when one sensor is in error, the temperature value detected by the other sensor is used.

——**Parameter "Period for request external sensor [0...255,0=inactive]"**

This parameter is for setting the time period for read request external temperature sensor.

Options: **0...255min**

—Parameter“Send temperature when the result change by [0...10]”

This parameter is for setting when temperature turns to a certain value, whether to enable to send the current temperature value to the bus. Not send when disable. Options:

Disable

0.1K

0.2K

0.3K

...

10K

—Parameter“Cyclically send temperature [0...255,0=inactive]”

Setting the time for cyclically sending the temperature detection value to the bus. Not send when value is 0. Options: **0...255min**

Parameter“Control value after temp. error [0..100](if 2-point control, set value '0'=0, set value '>0'=1)”

This parameter is for setting the control value when temperature error occur. Options: **0..100 %**

If PI control, the parameter value is 40%, as well as the control value. When set to invert, the control value is invert to 60%.

If 2-Point control, then the parameter value is 0, as well as the control value; if the parameter value is more than 0, then the control value will be 1. When set to invert, the control value is invert.

For additional heating and cooling control, when the temperature sensor is error, the control value is 0 or 0%. When set to invert, the control value is 1 or 100%.

Parameter“Room temperature control mode ”

This parameter is for setting room temperature control mode. Options:

Heating

Cooling

Heating and Cooling

Parameters as follow are visible when “Heating and Cooling” is selected:

—Parameter “Heating/Cooling switchover”

This parameter is for setting the switchover way of Heating/Cooling. Options:

Via object

Automatic changeover

—Parameter “Heating/Cooling status after download”

This parameter is for setting the heating/cooling control mode of device when power on RTC after download.

Heating

Cooling

—Parameter “Heating/Cooling status after voltage recovery”

This parameter is for setting the heating/cooling control mode of device when power on RTC after voltage recovery. Options:

Heating

Cooling

As before voltage failure

As before voltage failure: When the device is reset after power on, the control mode will recover as before voltage failure. If it is the first time the device is used or a newly enabled device function, the control mode after the device is started is in an uncertain state, and it needs to be manually selected at this time.

—Parameter “Room temperature control system”

This parameter is for setting the type of RTC control system, that is, pipe types of fan coil water inlet/outlet. Options:

2 pipes system

4 pipes system

2 pipes system: Shares an inlet and outlet pipe for heating and cooling, that is, both hot and cold water are controlled by a valve.

4 pipes system: Has its own inlet and outlet pipes for heating and cooling, and two valves are needed to control the entry and exit of hot water and cold water respectively.

Parameter "Operation mode"

This parameter is for setting whether to enable RTC operation mode.

Parameters as follow are visible when operation mode disabled:

—Parameter "Initial setpoint temperature"

This parameter is for setting the initial value of setpoint temperature. Options:

10.0°C

10.5°C

...

34.5°C

35.0°C

—Parameter "Min. setpoint temperature [5..37]"

—Parameter "Max. setpoint temperature [5..37]"

These parameters are for setting limit the adjustable range of the setpoint temperature, the minimum value should be less than the maximum value. If the setpoint temperature beyond the limited range, the will output the limited temperature. Options:

5°C

6°C

...

37°C

Automatic H/C mode changeover dead zone

—Parameter“ Upper dead zone”

—Parameter“ Lower dead zone”

These parameter is visible when “Heating/Cooling switchover” and “Automatic changeover” is selected. Set the dead zone range of auto switchover heating/cooling. Options:

0.5K

1.0K

...

10.0K

Under heating control, when the actual temperature(T) > or = the setpoint temperature + the upper dead zone, then mode heating switch to cooling.

Under cooling control, when the actual temperature(T) < or = the setpoint temperature + the upper dead zone, then mode cooling switch to heating.

Parameters as follow are visible when operation mode enabled:

—Parameter“ Controller status after download”

This parameter is for setting the operation mode when power on RTC after download. Options:

Standby mode

Comfort mode

Economy mode

—Parameter“Controller status after voltage recovery ”

This parameter is for setting the operation mode when power on RTC after voltage recovery.

Options:

Comfort mode

Standby mode

Economy mode

Frost/heat protection**As before voltage failure****—Parameter“Extended comfort mode [0..255,0=inactive]”**

This parameter is for setting the extended time of comfort mode. When value >0, activate the extended, and 1 bit object “Extended comfort mode” is visible. Options: **0..255 min**

When object receives telegram 1, comfort mode activation. If receive telegram 1 again during the delay time, the time is re-timing. And comfort mode will return to previous operation mode once finish the timing. Exit the comfort mode when a new operation mode in delay time.

If change the operation mode, exit the timing, but switch the heating/cooling will not.

—Parameter“1 bit object function for operation mode”

This parameter is for setting whether to enable 1 bit objects of operation mode are visible. Corresponding mode activation when objects send telegram 1; Perform standby mode when object values of comfort, economy, protection received from the bus are 0.

—Parameter“1 bit object for standby mode”

This parameter is visible when previous parameter enabled. Set whether to enable 1 bit object of standby mode is visible.

Parameter“Fan speed auto control function”

This parameter is for setting whether to enable fan auto control interface is visible.

Parameter“Window contact input function”

This parameter is visible when RTC operation mode enabled. Set whether to link to window contact status.

Parameters as follow are visible when“Window contact input function” enabled:**—Parameter“Delay for window contact [0..65535]”**

This parameter is visible when RTC operation mode and window contact input function are enabled. Set the delay time to window contact detection. That is, when the window is open within the

set value, the window is not open. If the time is out of the set value, the window is open. Options:

0..65535 s

—Parameter“Controller mode for open window”

This parameter is visible when RTC operation mode and window contact input function are enabled. If window status is open, perform corresponding operation according to configuration. (For the operation mode, the Switch and Setpoint temperature, as well as Heating/Cooling mode are recorded in the background if a control telegram is received, and performed after the window is closed. If no logging is received, return to the mode before the window was opened.)

Options:

Economy mode

Frost/heat protection

Parameter“Bus presence detector function”

This parameter is visible when RTC operation mode enabled. Set whether to link to bus presence detector status.

If presence is detected, enter the comfort mode and recovery original mode after leaving. If there is a telegram/manual to adjust the mode, it will not recovery the previous mode after leaving. (If receive presence status cyclically, no comfort mode re-triggered, and only can be after leaving.)

5.5.2. Parameter window "Setpoint"

Setpoint method for operating mode Relative Absolute

Fig.5.5.2 Parameter window "Setpoint"

Parameter "Setpoint method for operating mode"

This parameter is for setting the setpoint method for operating mode. Options:

Relative

Absolute

Relative: Relative adjustment, the setting temperature of economy mode and standby mode will refer to the defined temperature setpoint. More details refer to chapter 5.5.2.1.

Absolute: Absolute adjustment, each mode has its independent temperature setpoint. More details refer to chapter 5.5.2.2.

5.5.2.1.Relative

Parameters as follow are visible when the setpoint temperature adopts the relative adjustment method.

Setpoint method for operating mode	<input checked="" type="radio"/> Relative <input type="radio"/> Absolute
Base setpoint temperature	20.0 °C
Additional setpoint offset for setpoint adjustment	<input checked="" type="checkbox"/>
Step of setpoint offset	<input checked="" type="radio"/> 0.5K <input type="radio"/> 1K
Min. setpoint offset [-10..0]	-5 K
Max. setpoint offset [0..10]	5 K
Automatic H/C mode changeover dead zone (only for comfort mode)	
Upper dead zone	2.0 K
Lower dead zone	2.0 K
<hr/>	
Heating	
Reduced heating in standby mode [0..10]	2 K
Reduced heating in economy mode [0..10]	4 K
Setpoint temperature in frost protection mode [5..10]	7 °C
Cooling	
Increased cooling in standby mode [0..10]	2 K
Increased cooling in economy mode [0..10]	4 K
Setpoint temperature in heat protection mode [30..37]	35 °C
<hr/>	
Min. setpoint temperature [5..37]	10 °C
Max. setpoint temperature [5..37]	32 °C

Fig.5.5.2.1 Relative

Parameter "Base setpoint temperature"

This parameter is for setting the basic setpoint temperature, from which the initial setpoint temperature of the room comfort mode is obtained. Options:

10.0°C

10.5°C

...

35.0°C

The setpoint value will be modified through object "Base setpoint adjustment", then the new value will be stored after the device power off.

Current basic setpoint temperature = modified basic setpoint temperature +/- accumulated offset (if existence)

When adjusting the setpoint temperature of current operation mode, the setpoint value will be changed with it, but the relative temperature of each mode is unchanged. Relative temperature of standby, economy and comfort mode is set by the parameters as follows.

Parameter "Additional setpoint offset for setpoint adjustment"

This parameter is for setting whether to enable additional setpoint offset function for setpoint adjustment, mainly used to adjust setpoint temperature by 1 bit object.

Increase/decrease offset by 1 bit object "Setpoint offset", adjust the setpoint temperature indirectly, and send offset value to the bus by 2 byte object "Float offset value". Also reset the offset value by 1 bit object "Setpoint offset reset", modified the offset value by 2 byte object "Float offset value". Save the offset value when control mode and operation mode changed.

Parameters as follow are visible when "Additional setpoint offset for setpoint adjustment" enabled:

—Parameter "Step of setpoint offset"

This parameter is for setting step value of setpoint offset increased/decreased when receiving telegrams. Telegram 1- increase, telegram 0- decrease. Accumulated offset can be saved when power

off. Options:

0.5K

1K

Setpoint temperature of current mode = base temperature + fix offset of mode + accumulated additional offset

Note: Fix offset of mode is the offset of standby and economy modes compared to comfort mode, which is decided by the follow parameters of heating/cooling. Accumulated additional offset is adjusted by 1bit object "Setpoint offset", or directly modified the offset value by 2 byte object "Float offset value".

——Parameter"Min. setpoint offset [-10..0]"

This parameter is for setting the maximum offset allowed when negative offset (setpoint temperature is decreased).

Options: **-10..0 K**

——Parameter"Max. setpoint offset [0..10]"

This parameter is for setting the maximum offset allowed when forward offset (setpoint temperature is increased).

Options: **0..10 K**

Automatic H/C mode changeover dead zone (only for comfort mode)

——Parameter" Upper dead zone"

——Parameter" Lower dead zone"

These two parameters are visible when control mode "Heating and Cooling" is selected, and "Automatic changeover" is selected. Setting the dead zone range of auto switchover heating/cooling.

Options:

0.5K

1.0K

...

10K

Under heating control, when the actual temperature(T) > or = the setpoint temperature + the upper dead zone, then mode heating switch to cooling.

Under cooling control, when the actual temperature(T) < or = the setpoint temperature + the upper dead zone, then mode cooling switch to heating.

Heating/Cooling

——Parameter“Reduced heating in standby mode [0...10]”

——Parameter“Increased cooling in standby mode [0...10]”

These two parameters are for setting the setpoint of standby mode. Options:

0K

1K

...

10K

Heating: The setpoint of standby mode is the temperature setpoint minus the reference value.

Cooling: The setpoint of standby mode is the temperature setpoint plus the reference value.

——Parameter“Reduced heating in economy mode [0...10]”

——Parameter“Increased cooling in economy mode [0...10]”

These two parameters are for setting the setpoint of economy mode. Options:

0K

1K

...

10K

Heating: The setpoint of economy mode is the temperature setpoint minus the reference value;

Cooling: The setpoint of economy mode is the temperature setpoint plus the reference value.

——Parameter“Setpoint temperature in frost protection mode [5...10]”

This parameter is for setting the setpoint of frost protection mode. Options:

- 5°C**
- 6°C**
- ...
- 10°C**

Under the frost protection mode, when room temperature reduce to the setpoint, the controller will trigger a control telegram so that related heating controller will output heating control to prevent the temperature from being too low.

——Parameter "Setpoint temperature in heat protection mode [30...37]"

This parameter is for setting the setpoint of heat protection mode. Options:

- 30°C**
- 31°C**
- ...
- 37°C**

Under the heat protection mode, when room temperature raise to the setpoint, the controller will trigger a control telegram so that related cooling controller will output cooling control to prevent the temperature from being too high.

Parameter "Min. setpoint temperature [5..37]"

Parameter "Max. setpoint temperature [5..37]"

These parameters are for setting limit the adjustable range of the setpoint temperature, the minimum value should be less than the maximum value. If the setpoint temperature beyond the limited range, the will output the limited temperature. Options:

- 5°C**
- 6°C**
- ...
- 37°C**

5.5.2.2.Absolute

Parameters as follow are visible when the setpoint temperature adopts the absolute adjustment method.

Setpoint method for operating mode Relative Absolute

Heating

Setpoint temperature in comfort mode [5..37] 21 °C

Setpoint temperature in standby mode [5..37] 19 °C

Setpoint temperature in economy mode [5..37] 17 °C

Setpoint temperature in frost protection mode [5..10] 7 °C

Cooling

Setpoint temperature in comfort mode [5..37] 23 °C

Setpoint temperature in standby mode [5..37] 25 °C

Setpoint temperature in economy mode [5..37] 27 °C

Setpoint temperature in heat protection mode [30..37] 35 °C

i Note: The heating setpoint must be always less than the cooling setpoint.

Min. setpoint temperature [5..37] 10 °C

Max. setpoint temperature [5..37] 32 °C

Fig.5.5.2.2 Absolute

Heating/Cooling

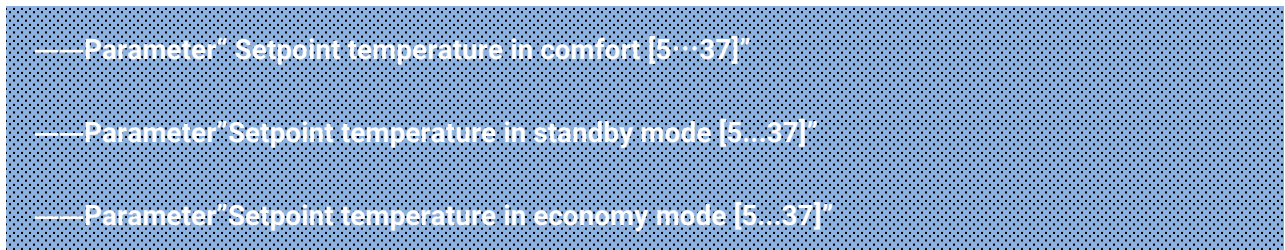

These parameters are for setting the setpoint temperature in comfort, standby and economy mode when heating or cooling. Options:

5°C
6°C
...
37°C

— Parameter "Setpoint temperature in frost protection mode [5...10] °"

This parameter is for setting the setpoint temperature in frost protection mode when heating.

Options:

5°C
6°C
...
10°C

— Parameter "Setpoint temperature in heat protection mode [30...37] °"

This parameter is for setting the setpoint temperature in heat protection mode when cooling.

Options:

30°C
31°C
...
37°C

 Note: The heating setpoint must be always less than the cooling setpoint.

For absolute adjustment mode, "Heating and Cooling" and "Automatic changeover" are selected, the note is visible. The heating setpoint value must be less than or equal to the cooling of the same operation mode, if not, it can not be configured on ETS. It is also applied to "Via object".

1. When the ambient temperature is higher than the setpoint temperature of current mode, it is

changed to cooling mode; When the ambient temperature is lower than the setpoint temperature of current mode, it is changed to heating mode.

2. In the same operation mode, the setpoint temperature difference between cooling and heating remains constant, whether it is written from the bus or adjusted on the panel. That is, when adjust the setpoint temperature, it need to update cooling and heating setpoint temperature of current operation mode at the same time.

3. For the abnormal configuration where the heating setpoint value is greater than the cooling, it is depend on the setpoint temperature and ambient temperature to adjust heating/cooling mode, that is, change to cooling when ambient temperature is higher than the setpoint temperature in the current operation mode of cooling, while change to heating when ambient temperature is lower than the setpoint temperature in the current operation mode of cooling.

4. When receiving setpoint temperature from bus, it is still necessary to limit the value according to the high and low thresholds, that is heating and cooling temperature neither can not be lower than the min., or can not be higher than the max..

Points 2 and 4 also apply to "Via object".

Note: for relative/absolute adjustment, in protection mode, the setpoint temperature is only configured via ETS. When the received setpoint value from bus is different from the ETS configuration, the value is not updated and returned to the current setpoint temperature, to update synchronously to other devices on the bus.

Parameter "Min. setpoint temperature [5..37]"

Parameter "Max. setpoint temperature [5..37]"

These parameters are for setting limit the adjustable range of the setpoint temperature, the minimum value should be less than the maximum value. If the setpoint temperature beyond the limited range, the will output the limited temperature.

Options: 5°C/6°C/.../37°C

5.5.3.Parameter window“Heating/Cooling control”

This parameter window is displayed according to the control mode.

Type of heating/cooling control	<input type="text" value="Switching on/off(use 2-point control)"/>	
Invert control value	<input checked="" type="checkbox"/>	
Heating		
Lower Hysteresis [0..200]	<input type="text" value="10"/>	*0.1K
Upper Hysteresis [0..200]	<input type="text" value="10"/>	*0.1K
Cooling		
Lower Hysteresis [0..200]	<input type="text" value="10"/>	*0.1K
Upper Hysteresis [0..200]	<input type="text" value="10"/>	*0.1K
Cyclically send control value [0..255]	<input type="text" value="10"/>	min

Switching on/off(use 2-point control)

Type of heating/cooling control	<input type="text" value="Switching PWM(use PI control)"/>	
Invert control value	<input checked="" type="checkbox"/>	
PWM cycle time [1..255]	<input type="text" value="15"/>	min
Heating speed	<input type="text" value="Hot water heating(5K/150min)"/>	
Cooling speed	<input type="text" value="Cooling ceiling (5K/240min)"/>	
Cyclically send control value [0..255]	<input type="text" value="10"/>	min

Switching PWM(use PI control)

Type of heating/cooling control	<input type="text" value="Continuous control(use PI control)"/>	
Invert control value	<input checked="" type="checkbox"/>	
Heating speed	<input type="text" value="Hot water heating(5K/150min)"/>	
Cooling speed	<input type="text" value="Cooling ceiling (5K/240min)"/>	
Send control value on change by [0..100,0=inactive]	<input type="text" value="5"/>	%
Cyclically send control value [0..255]	<input type="text" value="10"/>	min

Continuous control(use PI control)

Additional heating/cooling	<input checked="" type="checkbox"/>
Control type	<input checked="" type="radio"/> 1bit <input type="radio"/> 1byte
Invert control value	<input type="checkbox"/>
Temperature difference to switch on additional heating [-100..-5]	-25 *0.1K
Hysteresis to switch off additional heating [-20..-1]	-5 *0.1K
Temperature difference to switch on additional cooling [5..100]	25 *0.1K
Hysteresis to switch off additional cooling [1..20]	5 *0.1K
Cyclically send control value [0..255]	0 min

Additional heating/cooling

Fig.5.5.3(1) Parameter window "Heating/Cooling control"

Parameters of this window display according to control mode and control system(2 pipe or 4pipe).

Parameter "Type of heating/cooling control"

This parameter is visible when selecting "Heating and Cooling & 2-pipe" option, setting the type of heating/cooling control. Different control types are suitable for controlling different temperature controllers. Options:

Switching on/off(use 2-point control)

Switching PWM(use PI control)

Continuous control(use PI control)

Parameter "Invert control value"

This parameter is for setting whether to invert control value or normal sending control value, so that the control value will be suitable for the valve type.

Enable Sending the control value to the bus through objects after inverting the control value.

Heating/Cooling

Two parameters as follow are suitable for 2 point control:

Parameter*Lower Hysteresis [0..200]*

Parameter*Upper Hysteresis [0..200]*

These two parameters are for setting the lower/upper hysteresis temperature in HVAC heating or cooling. Options: **0..200 *0.1K**

Under heating control,

When the actual temperature(T) > the setting temperature + the upper hysteresis temperature, then will stop heating;

When the actual temperature(T) < the setting temperature - the lower hysteresis temperature, then will start heating.

For example, the lower hysteresis temperature is 1K, the upper hysteresis temperature is 2K, the setting temperature is 22°C, if T is higher than 24°C, then it will stop heating; if T is lower than 24°C, then it will start heating; if T is between 21~24°C, then it will maintain the previous status.

Under the cooling control,

When the actual temperature (T) < the setting temperature -the lower hysteresis temperature, then will stop cooling;

When the actual temperature (T) > the setting temperature +the upper hysteresis temperature, then will start cooling.

For example, the lower hysteresis temperature is 1K, the upper hysteresis temperature is 2K, the setting temperature is 26°C, if T is lower than 25°C, then it will stop cooling; if T is lower than 28°C, then it will start cooling; if T is between 28~25°C, then it will maintain the previous status.

2-point control mode is a very simple control mode. When adopting this control mode, it is necessary to set the upper hysteresis temperature and the lower hysteresis temperature through parameters. When setting the hysteresis temperature, the following effects need to be considered

1. When hysteresis interval is small, the temperature range will be small, however, frequent sending of control value will bring large load to the bus;

2. When hysteresis interval is large, the switch switching frequency will be low, but it is easy to

cause uncomfortable temperature change.

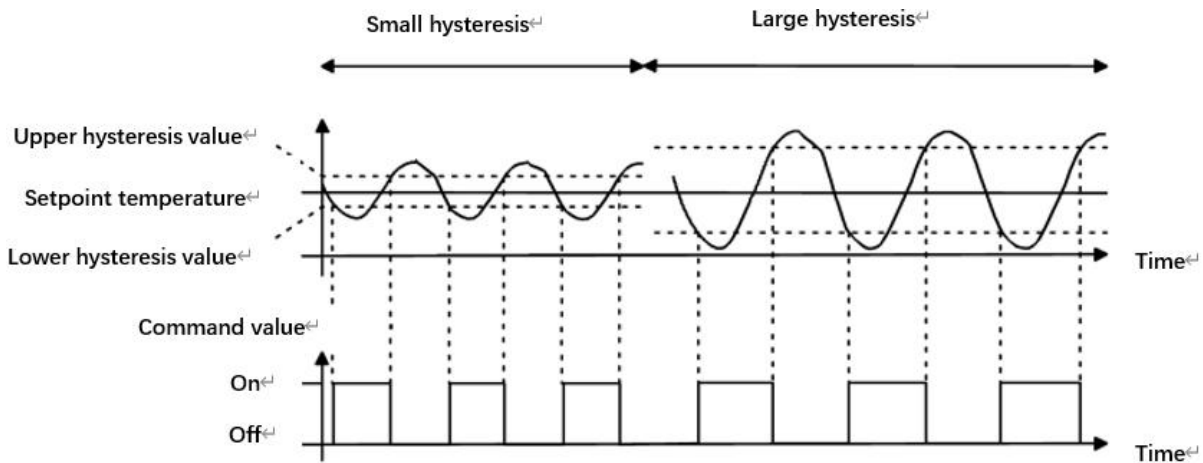

Fig.5.5.3(2) Effects of hysteresis on control value switch action(heating) under 2-point control mode

Parameters as follow are suitable for PWN control:

Parameter "PWM cycle time [1...255]"

This parameter is only visible when the control type is "Switching PWM(use PI control)". Set the period of the control object cycle to send the switch value, the object sends the switch value according to the duty cycle of the control value. For example, if the set period is 10 min and the control value is 80%, then the object will send an open telegram for 8 min. If the control value is changed, the time duty ratio of the on/ off telegram of the object will also change, but the period is still the time of parameter setting.

Options: **1..255 min**

The PI values of "Switching PWM (use PI control)" and "Continuous control (use PI control)" are the same, only different in control objects, the control object of "Continuous control" output PI value(1byte) directly, while the control value of "Switching PWM" output a "on/off" telegram according to the duty cycle of the control value.

Parameters as follow are suitable for PI control:

Parameter "Heating speed"

Parameter "Cooling speed"

These two parameters are for setting the responding speed of heating or cooling controller.

Different responding speeds are suitable for different environments.

Options:

Hot water heating (5K/150min)

Underfloor heating (5K/240 min)

Electrical heating (4K/100min)

Split unit (4K/90min)

Fan coil unit (4K/90min)

User defined

Options:

Cooling ceiling (5K/240min)

Split unit (4K/90min)

Fan coil unit(4K/90min)

User defined

—Parameter "Proportional range [10..100]"

—Parameter "Reset time [0..255]"

These two parameters are visible when "User defined" is selected. Set the PI value of PI controller.

Options: **10..100*0.1K (P value)**

Options: **0..255min (I value)**

Parameter "Send control value on change by [0...100.0=inactive]"

This parameter is visible when control type is "Continuous control (use PI control)", for setting the changing value of the control value to be sent to the bus. Options: **0..100 %**, **0=inactive**

In PI control mode, the predefined control parameters of each PI controller in heating or cooling system are recommended as follows:

(1) (1) Heating

Heating type	P value	I value(integration time)	Recommended PI control type	Recommended PWM period
Hot water Heating	5K	150min	Continuous/PWM	15min
Underfloor heating	5K	240min	PWM	15-20min
Electrical heating	4K	100min	PWM	10-15min
Split unit	4K	90min	PWM	10-15min
Fan coil unit	4K	90min	Continuous	--

(2) Cooling

Cooling type	P value	I value(integration time)	Recommended PI control type	Recommended PWM period
Cooling ceiling	5K	240min	PWM	15-20min
Split unit	4K	90min	PWM	10-15min
Fan coil unit	4K	90min	Continuous	--

(3) User defined

When the parameter “Heating/Cooling speed” is set to “User defined”, the parameter value of P (scale factor) and I (integration time) can be set through the parameter. When adjusting the parameters, refer to the fixed PI value mentioned in the above table. Even if the control parameters are adjusted slightly, the control behavior will be significantly different.

In addition, the integration time should be set properly. If the integration time is too long, the adjustment will be slow, and the oscillation will not be obvious; if the integration time is too small, the adjustment will be fast, but the oscillation will occur. 0 means the integral term is not used.

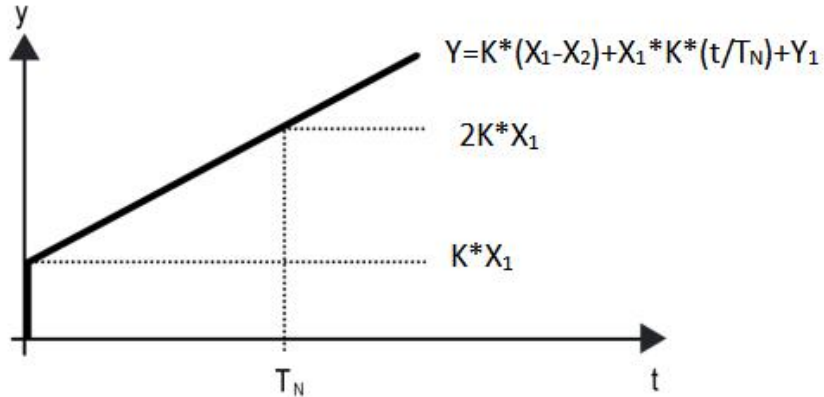

Fig.5.5.3(3) control value of PI control mode

Y: control value

Y1: last control value

X1: temperature deviation = set temperature - actual temperature

X2: last temperature deviation = set temperature - actual temperature

T_N: integration time

K: scale factor (the scale factor is not zero)

PI control algorithm: $Y = K * (X1 - X2) + X1 * K * t / T_N + Y1$

When the integration time is set to zero, the PI control algorithm is: $Y = K (X1 - X2) + Y2$

Setting and influence of user-defined parameters:

Parameter setting	Effect
K: If the scale range is too small	Quick adjustment, and overshoot will occur
K: If the scale range is too small	Slow adjustment, but no overshoot

T _N : If the integration time is too short	Quick adjustment, but there will be oscillation
T _N : If the integration time is too long	Slow adjustment, no obvious oscillation

Parameter "Cyclically send control value 0..255"

This parameter is for setting the period for cyclically sending the control value to the bus.

Options: **0..255 min**

Parameter "Additional heating/cooling"

This parameter is for setting whether to enable additional heating.

Parameter as follow are visible when "Additional heating" is enable:

—Parameter "Control type"

This parameter is for setting the control type for the additional heating. Options:

1bit

1byte

—Parameter "Invert control value"

This parameter is for setting whether to invert control value or normal sending control value, so that the control value will be suitable for the valve type.

When enabled, sending the control value to the bus through objects after inverting the control value.

For additional heating valve:

—Parameter“Temperature difference to switch on additional heating [-100..-5]”

This parameter is for setting the temperature difference to switch on additional heating valve.

When the actual temperature (T) < (Setpoint temperature + Temperature difference), start heating.

Options: -100...-5 *0.1K

—Parameter“Hysteresis to switch off additional heating [-20..-1]”

This parameter is for setting the hysteresis to switch off additional heating.

When the actual temperature (T) > (Setpoint temperature + Temperature difference - Hysteresis), then will stop heating.

Options: -20... -1 *0.1K

Note: |Hysteresis| < |Temperature difference|, if not meet the condition, they can not be configured in ETS, and display red box warning, as shown as follow:

Temperature difference to switch on additional heating [-100..-5]	<input type="text" value="-9"/>	*0.1K
Hysteresis to switch off additional heating [-20..-1]	<input style="border: 2px solid red;" type="text" value="-10"/>	*0.1K

For additional cooling valve:

—Parameter“Temperature difference to switch on additional cooling [5..100]”

This parameter is for setting the temperature difference to switch on additional cooling valve.

When the actual temperature (T) > (Setpoint temperature + Temperature difference), start cooling.

Options: 5...100 *0.1K

—Parameter“Hysteresis to switch off additional cooling [1..20]”

This parameter is for setting the hysteresis to switch off additional cooling.

When the actual temperature (T) < (Setpoint temperature + Temperature difference - Hysteresis), then will stop cooling.

Options: 1...20 *0.1K

Note: $|\text{Hysteresis}| < |\text{Temperature difference}|$, if not meet the condition, they can not be configured in ETS, and display red box warning, as shown as follow:

Temperature difference to switch on additional cooling [5..100]	<input type="text" value="19"/>	*0.1K
Hysteresis to switch off additional cooling [1..20]	<input type="text" value="20"/>	*0.1K

——Parameter“Cyclically send control value [0..255]”

This parameter is for setting the period for cyclically sending the control value to the bus.

Options: 0..255 min

5.5.4.Parameter window“Fan auto.control”

This parameter window is visible when fan speed auto.control function is enabled.

Auto. operation on object value Auto=1/Man.=0 Auto=0/Man.=1

Fan speed output setting

Object datatype of 1byte fan speed Fan stage (DPT_5.100)
 Percentage (DPT_5.001)

Output value for fan speed low %

Output value for fan speed medium %

Output value for fan speed high %

1 bit object function for fan speed

Fan speed control setting

Condition setting for using 2-point control

Temperature difference speed OFF<-->low [0..200] *0.1K

Temperature difference speed low<-->medium [1..200] *0.1K

Temperature difference speed medium<-->high [1..200] *0.1K

Hysteresis temperature difference in [0..50] *0.1K

Condition setting for using PI control

Threshold value speed OFF<-->low [0..255]

Threshold value speed low<-->medium [1..255]

Threshold value speed medium<-->high [1..255]

Hysteresis threshold value in +/-[0..50]

Minimum time in fan speed [0..65535] s

Fig.5.5.4 Parameter window“Fan auto.control”

Parameter "Auto. operation on object value"

This parameter is for setting the telegram value to activate automatic operation. Options:

Auto=1/Man.=0

Auto=0/Man.=1

Auto=1/Man.=0: When the object "Fan automatic operation" receives the telegram value "1", activate the automatic operation, when receive "0", exit the automatic operation.

Auto=0/Man.=1: When the object "Fan automatic operation" receives the telegram value "0", activate the automatic operation, when receive "1", exit the automatic operation.

After power-on, automatic operation is not activated by default.

Fan speed output setting

Parameter "Object datatype of 1byte fan speed"

This parameter is for setting the object datatype of 1 byte fan speed. Options:

Percentage (DPT_5.001)

Fan stage (DPT_5.100)

Parameter "Output value for fan speed low/medium/high"

These three parameters are for setting the value sent for each fan speed switchover. Fan speed off when value is 0.

Options according to fan object datatype: **1..255 / 1..100%**

Note: the out value and status value must meet the condition low<medium<high, if not, they can not be configured on ETS, and display red box warning, as shown as follow:

Output value for fan speed low	<input style="border: 2px solid red;" type="text" value="3"/>	▲▼
Output value for fan speed medium	<input type="text" value="2"/>	▲▼
Output value for fan speed high	<input type="text" value="3"/>	▲▼

Parameter "1 bit object function for fan speed"

This parameter is for setting whether to enable 1 bit object function for fan speed. 1 bit control

objects of each fan speed are visible when enabled.

—Parameter“1 bit object for fan speed off ”

This parameter is visible when previous parameter is enabled. Set whether to enable 1 bit object of fan speed off .

Fan speed control setting

Condition setting for using PI control

Under PI control, control value is PI operated within program, controller will power on/off fan or switch fan speed according to the threshold range of the control values.

—Parameter“Threshold value speed OFF<->low [0..255]”

Define threshold value for off-fan and low-level fan speeds, options: **0..255**

When the configuration is not 0, if the control value is greater than or equal to this setting threshold value, low-level fan speed will start running; if the control value is less than this setting threshold value, the fan will be turned off.

When the configuration is set to 0, it indicates that is the fan speed cannot be turned off and the lowest fan speed is at low-level.

—Parameter“Threshold value speed low<->medium [1..255]”

Define the threshold value for switching the fan speed to medium fan speed, if the control value is greater than or equal to this setting threshold, the medium fan speed will start running. Options: **1..255**

—Parameter“Threshold value speed medium<->high [1..255]”

Define the threshold for switching the fan speed to high fan speed, if the control value is greater than or equal to this setting threshold, the high fan speed will start running. Options: **1..255**

Tip: The controller evaluates the threshold in ascending order.

First check →OFF <->low fan speed threshold →low fan speed <->medium fan speed →medium fan speed <->high fan speed.

The correctness of functional execution is guaranteed only in this case:

The threshold of OFF <-> low fan speed is lower than that of low fan speed <-> medium fan speed, and the threshold of low fan speed <-> medium fan speed is lower than that of medium fan speed <-> high fan speed.

——Parameter“Hysteresis threshold value in +/-[0..50]”

This parameter is for setting the hysteresis value of the threshold value, which can avoid the unnecessary action of the fan when the control value fluctuates near the threshold. Options: **0..50**

If value is 0, no hysteresis. Fan switch to speed once control value greater than threshold value;

Suppose that hysteresis value is 10 and the threshold is 50, then the upper limit threshold 60 (Threshold value+Hysteresis value) and the lower limit threshold 40 (Threshold value-Hysteresis value). When the control value is between 40 ~60, fan action will not be caused, and the previous status will still be maintained. Only less than 40 or greater than or equal to 60 will change the running status of the fan.

Condition setting for using 2-point control

Under 2-point control, controller will decide the fan power on/off or fan speed according to the temperature difference between the actual temperature and setpoint temperature.

Cooling: Temperature difference = actual temperature - setpoint temperature.

Heating: Temperature difference = setpoint temperature - actual temperature.

——Parameter“Temperature difference speed OFF<->low[0..200]”

This parameter is for setting the temperature difference between off-fan and low-level fan speeds.

Options: **0..200 *0.1K**

When the configuration is not 0, if the temperature difference is greater than or equal to this setting temperature difference, low-level fan speed will start running; if less than this setting temperature difference, the fan will be turned off.

When the configuration is set to 0, it indicates that is the fan speed cannot be turned off and the lowest fan speed is at low-level.

——Parameter“Temperature difference speed low<-->medium [1..200]”

Define the temperature difference for switching the fan speed to medium fan speed, if the control value is greater than or equal to this setting temperature difference, the medium fan speed will start running.

Options: **1..200 *0.1K**

——Parameter“Temperature difference speed medium<-->high [1..200]”

Define the temperature difference for switching the fan speed to high fan speed, if the control value is greater than or equal to this setting temperature difference, the high fan speed will start running. Options: **1..200 *0.1K**

——Parameter“Hysteresis temperature difference in [0..50]”

This parameter is for setting the hysteresis value of the temperature difference, which can avoid the unnecessary action of the fan when the control value fluctuates near the temperature difference.

Options: **0..50 *0.1K**

If value is 0, no hysteresis. Fan switch to speed once control value greater than temperature difference.

Suppose that hysteresis value is 0.5°C and the temperature difference is 1°C, then the upper limit temperature difference 1.5°C (Temperature difference+Hysteresis value) and the lower limit temperature difference 0.5°C (Temperature difference-Hysteresis value). When the control value is between 0.5°C~1.5°C, fan action will not be caused, and the previous status will still be maintained. Only less than 0.5°C or greater than or equal to 1.5°C will change the running status of the fan.

——Parameter“Minimum time in fan speed [0..65535]”

Defines the residence time of the fan from the current fan speed to a higher fan speed or lower fan speed, that is, the minimum time for a fan speed operation.

If you need to switch to another fan speed, you need to wait for this period of time before switching.

If the current fan speed has been running long enough, the fan speed can be changed quickly.

Options: **0..65535 s**

0: there is no minimum running time.

Note: The residence time for this parameter setting is only enabled in Auto mode.

5.6.Parameter window“Input”

The screenshot shows a configuration window for 'Input'. It has three rows. The first row is 'Input 1' with a checked checkbox. The second row is 'Input 2' with an unchecked checkbox. The third row is 'Function' with a dropdown menu showing 'BI: Switch sensor'.

Fig.5.6 Parameter window“Input”

Parameter “Input x”(x=1, 2)

Function page of input interface is visible after this parameter enabled.

Parameter “Function”

This parameter is for setting the function of external input interface. Support temperature detection and dry contact input (BI), setting page will be visible when select corresponding chosen.

Also can be disable this channel function. Options:

Disable

Temperature probe(NTC 10K)

BI: Switch sensor

BI: Scene control

BI: Send String(14bytes)

When select Temperature probe(NTC 10K), can detect external temperature, which needs set B value of temperature probe.

When select dry contact input (BI), only supports the basic functions, including switch, scene send strings (press/release, short/long, send after voltage recovery, disable function).

Chapters as follow explain the functions of external input interface separately.

5.6.1. Temperature probe

Function	Temperature probe(NTC 10K) ▼
Description (max 30char.)	<input type="text"/>
B value of temperature sensor (must refer to the characteristic of component)	3950 ▼
Temperature calibration	0.0 ▼ K
Send temperature when the result change by	1.0 ▼ K
Cyclically send temperature [0...255]	0 ▲▼ min
Reply error of sensor measurement	Respond after read only ▼
Object value of error	<input checked="" type="radio"/> 0=no error/1=error <input type="radio"/> 1=no error/0=error
Lower threshold value for error report	0 ▼ °C
Upper threshold value for error report	60 ▼ °C

Fig.5.6.1 Temperature probe(NTC 10K)

Parameter "Description (max 30char.)"

This parameter is for setting the name description of temperature probe.

Parameter "B value of temperature sensor(must refer to the characteristic of component)"

This parameter is for setting the B value of temperature sensor. Options:

- 3275
- 3380
- ...
- 4200

Note: This value must refer to the characteristic of component, available from the instruction manual. If selected B value is different from used sensor, it will effect detection result directly.

Parameter "Temperature calibration"

This parameter is for setting the temperature calibration value of the temperature sensor, that is, to calibrate the measured value of sensor to make it closer to the current ambient temperature.

Options:

-5.0K

...

0.0K

...

5.0K

Parameter "Send temperature when the result change by"

This parameter is for setting when temperature turns to a certain value, whether to enable to send the current temperature value to the bus. Not send when disable. Options:

Disable

0.1K

0.2K

0.3K

0.5K

1.0K

...

10.0K

Parameter "Cyclically send temperature [0..255,0=inactive]"

Setting the time for cyclically sending the temperature detection value to the bus. Not send when value is 0.

Options: **0..255 min**

Parameter "Reply error of sensor measurement"

This parameter for setting the condition of sending error status report when temperature exceeds the valid detection. options:

No respond

Respond after read only

Respond after change

Respond after read only: only when the device receives a read error from other bus device or bus will the object "Temperature error report, Sensor" send the error status to the bus.

Respond after change: the object "Temperature error report, Sensor" will immediately send the telegram to the bus to report the error value when the error status has changed.

Parameter as follow are visible when "Respond after read only" or "Respond after change" us selected:

—Parameter "Object value of error"

This parameter for defining object value of error. Options:

0=no error/1=error

1=no error/0=error

0=no error/1=error: the object value for which sensor no error occurs is 0, and the object value for which sensor error occurs is 1.

1=no error/0=error: it has the opposite meaning.

—Parameter "Upper threshold value for error report"

This parameter is for setting the upper threshold value for temperature error. When the temperature higher than the threshold, temperature error object will send telegram.

Options: **40°C / 45°C / 50°C / 55°C / 60°C / 70°C**

—Parameter "Lower threshold value for error report"

This parameter is for setting the lower threshold value for temperature error. When the temperature lower than the threshold, temperature error object will send telegram.

Options: **10°C / 5°C / 0°C / -5°C / -10°C / -20°C**

5.6.2.Binary input

Function	BI: Switch sensor
Description (max 30char.)	<input type="text"/>
Distinction between short and long operation	<input type="checkbox"/>
Reaction on close the contact	ON
Reaction on open the contact	OFF
Interval of tele. cyclic send [0..60000] (0=send once)	0 s
Send object value after voltage recovery (valid if reaction is not toggle)	<input type="checkbox"/>
Number of objects	<input checked="" type="radio"/> 1 <input type="radio"/> 2
Disable function	Disable=1/Enable=0
Behaviour from disable to enable (valid if reaction is not toggle)	<input checked="" type="radio"/> No reaction <input type="radio"/> Send the current status

BI: Switch sensor

Function	BI: Scene control
Description (max 30char.)	<input type="text"/>
Distinction between short and long operation	<input checked="" type="checkbox"/>
Long operation after [3..25]	5 *0.1s
Connected contact type	<input checked="" type="radio"/> Normally open <input type="radio"/> Normally closed
Reaction on short operation	Recall scene
8 bit scene number	Scene No.1
Reaction on long operation	Store scene
8 bit scene number	Scene No.1
Number of objects	<input checked="" type="radio"/> 1 <input type="radio"/> 2
Disable function	Disable=1/Enable=0

BI: Scene sensor

Function	<input type="text" value="BI: Send String(14bytes)"/>
Description (max 30char.)	<input type="text"/>
Distinction between short and long operation	<input type="checkbox"/>
Reaction on close the contact	<input type="radio"/> No reaction <input checked="" type="radio"/> Send Value
String (14byte) value	<input type="text" value="Hello, world !"/>
Reaction on open the contact	<input checked="" type="radio"/> No reaction <input type="radio"/> Send Value
Send object value after voltage recovery	<input type="checkbox"/>
Number of objects	<input checked="" type="radio"/> 1 <input type="radio"/> 2
Disable function	<input type="text" value="Disable=1/Enable=0"/>

BI: Send String(14bytes)

Fig.5.6.2 Binary input

Parameter "Description (max 30char.)"

This parameter is for setting the name description for binary input function.

Parameter "Distinction between short and long operation"

This parameter is for setting whether to distinction between short and long operation.

—Parameter "Long operation after [3..25]"

This parameter is visible when distinction between short and long operation. Set the effective time of long operation. When button operation out of the setting time, it is a long operation, otherwise it is a short operation.

Options: 3..25 *0.1s

—Parameter "Connected contact type"

This parameter is visible when distinction between short and long operation. Set the connected contact type.

Options:

Normally open

Normally closed

When function is selected “BI: Switch sensor”, the following parameters are visible, for setting switch sensor.

—Parameter “Reaction on short/long operation”

This parameter is visible when distinction between short and long operation, performing the action according to the settings of the short and long operations. Set the switch value to send when button operation. Options:

No reaction

OFF

ON

TOGGLE

No action: No telegrams have been sent.

ON: Send the on telegram.

OFF: Send the off telegram.

TOGGLE: Each operation will switch between on and off.

—Parameter “Reaction on close/open the contact”

This parameter is visible when no distinction between short and long operation. Judge the close and open operations, and perform the actions according to the settings. Set the switch value to send when button operation. Options:

No reaction

OFF

ON

TOGGLE

—Parameter “Interval of tele. cyclic send [0..60000] (0=send once)”

This parameter is visible when no distinction between short and long operation. Set the interval of telegram cyclic send. Options: **0..60000 s, 0 is only send once**

—Parameter **“Send object value after voltage recovery (valid if reaction is not toggle)”**

This parameter is visible when no distinction between short and long operation. This parameter is valid if not select “TOGGLE” or “No reaction”, set whether to send object value after voltage recovery.

—Parameter **“Behaviour from disable to enable(valid if reaction is not toggle)”**

This parameter is visible when “BI: Switch sensor” is selected and no distinction between short and long operation. Set the behaviour from disable to enable(valid if reaction is not toggle).Options:

No reaction

Send the current status

When function is selected “BI: Scene control”, the following parameters are visible, for setting scene control.

—Parameter **“Reaction on short/long operation”**

This parameter is visible when distinction between short and long operation, performing the action according to the settings of the short and long operations. Set the scene command to send when button operation. Options:

No reaction

Recall scene

Store scene

—Parameter **“Reaction on close/open the contact”**

This parameter is visible when no distinction between short and long operation. Judge the close and open operations, and send or storage scenes according to the settings. Set the scene command to send when button operation. Options:

No reaction

Recall scene

Store scene

——Parameter “8 bit scene number”

This parameter is visible when “Recall scene” or “Store scene” is selected. Set the scene number, range: **Scene NO.1~64, corresponding telegram is 0~63**

When function is selected “BI: Send String(14bytes)”, the following parameters are visible, for setting string sending.

——Parameter “Reaction on short/long operation”

This parameter is visible when distinction between short and long operation, performing the action according to the settings of the short and long operations. Options:

No reaction

Send Value

——Parameter “Reaction on close/open the contact”

This parameter is visible when no distinction between short and long operation. Judge the close and open operations, and send strings according to the settings. Options:

No reaction

Send Value

——Parameter “String (14byte) value”

This parameter is visible when “Send Value” is selected. Input the strings to send.

——Parameter “Send object value after voltage recovery”

This parameter is visible when no distinction between short and long operation. Set whether to send object value after voltage recovery.

Parameter “Number of objects”

This parameter is visible when the parameters "Reaction on short/close operation" or "Reaction on long/open operation" are not selected "No reaction". Set whether to use a common object or two separate objects when open/close and long/short operations. Options:

1

2

Parameter "Disable function"

This parameter is visible when binary input functions are selected. Set trigger value to disable/enable contacts. Options:

Disable

Disable=1/Enable=0

Disable=0/Enable=1

5.7.Parameter window“Logic function”

1st Logic function	<input checked="" type="checkbox"/>
2nd Logic function	<input checked="" type="checkbox"/>
3rd Logic function	<input checked="" type="checkbox"/>
4th Logic function	<input checked="" type="checkbox"/>
5th Logic function	<input checked="" type="checkbox"/>
6th Logic function	<input checked="" type="checkbox"/>
7th Logic function	<input checked="" type="checkbox"/>
8th Logic function	<input checked="" type="checkbox"/>

Description for logic function	<input type="text"/>
Function of channel	AND <input type="button" value="v"/>

Fig.5.7 Parameter window“Logic function”

Parameter “1st/2nd/3rd... Logic function”

This parameter is for setting the setting interface of logic function, display corresponding logic function page when select. Up to enable 8 logic functions.

Parameter “Description for logic function”

This parameter is for setting the name description for logic function, up to input 30 characters.

Parameter “Function of channel”

This parameter is for setting function of the channel. Options:

AND

OR

XOR

Gate forwarding

Threshold comparator

Format convert

Gate function

Delay function

Staircase lighting

AND/OR/XOR: as the parameter is similar to the communication object (only the logic algorithm is different), the following parameters taking one options for example.

5.7.1. Parameter window "AND/OR/XOR"

Description for logic function	<input type="text"/>
Function of channel	AND ▾
Input a	Disconnected ▾
Default value	<input checked="" type="radio"/> 0 <input type="radio"/> 1
Input b	Disconnected ▾
Default value	<input checked="" type="radio"/> 0 <input type="radio"/> 1
Input c	Disconnected ▾
Default value	<input checked="" type="radio"/> 0 <input type="radio"/> 1
Input d	Disconnected ▾
Default value	<input checked="" type="radio"/> 0 <input type="radio"/> 1
Input e	Disconnected ▾
Default value	<input checked="" type="radio"/> 0 <input type="radio"/> 1
Input f	Disconnected ▾
Default value	<input checked="" type="radio"/> 0 <input type="radio"/> 1
Input g	Disconnected ▾
Default value	<input checked="" type="radio"/> 0 <input type="radio"/> 1
Input h	Disconnected ▾
Default value	<input checked="" type="radio"/> 0 <input type="radio"/> 1
<hr/>	
Result is inverted	<input type="checkbox"/>
Read input object value after bus voltage recovery	<input type="checkbox"/>
Output send when	<input checked="" type="radio"/> Receiving a new telegram <input type="radio"/> Every change of output object
Send delay time: Base	None ▾
Factor: 1..255	1 ▲▼

Fig.5.7.1 Parameter window "AND/OR/XOR"

Parameter "Input a/b/c/d/e/f/g/h"

This parameter is for setting whether input x to calculate, whether to normally calculate or inverted calculate. Options:

Disconnected

Normal

Inverted

Disconnected: not to calculate.

Normal: to directly calculate the input value.

Inverted: invert the input value, then to calculate.

Note: not to invert the initiate value.

Parameter "Default value"

This parameter is for setting the initial value of logic input x. Options:

0

1

Parameter "Result is inverted"

This parameter is for setting whether to invert the logic calculation result.

Enable: output directly.

Disable: output after inverting.

Parameter "Read input object value after voltage recovery"

This parameter is for setting whether to send the read request to the logic input object after device voltage recovery or finish programming.

Parameter "Output send when"

This parameter is for setting the condition of sending logic result. Options:

Receiving a new telegram

Every change of output object

Receiving a new telegram: every time the object received a new input value will the logic result be sent to the bus.

Every change of output object: only when logic result has changed will it be sent to the bus.

Note: when in the first time to logic calculate, the logic result will be sent even if it has no change.

Parameter "Send delay time"

Base:	None
	0.1s
	1s
	...
	10s
	25s
Factor:	1..255

This parameter is for setting the delay time for sending the logic calculation result to the bus.

Delay time = Base × Factor, if option "None" of Base is selected, then there is no delay.

5.7.2.Parameter window“Gate forwarding”

Description for logic function	<input type="text"/>
Function of channel	Gate forwarding ▼
Object type of Input/Output	1bit ▼
Default scene NO. of Gate after startup [1~64,0=inactive]	0 ▲▼
<hr/>	
1->Gate trigger scene NO. is [1~64,0=inactive]	0 ▲▼
Input A send on	Output A ▼
Input B send on	Output B ▼
Input C send on	Output C ▼
Input D send on	Output D ▼
<hr/>	
2->Gate trigger scene NO. is [1~64,0=inactive]	0 ▲▼
Input A send on	Output A ▼
Input B send on	Output B ▼
Input C send on	Output C ▼
Input D send on	Output D ▼

Fig.5.7.2 Parameter window“Gate forwarding”

Parameter“Object type of Input/Output”

This parameter is for setting the object type of input/output. Options:

1bit

4bit

1byte

Parameter“Default scene NO. of Gate after startup [1~64,0=inactive]”

This parameter is for setting the initial scene where logical gate forwarding can be performed by

default after device starts, which needs to be configured in the parameters. Options: **1..64, 0=inactive**

Note: gate scene is recommended to be selected before operating, or it will enable the initiate scene by default.

Parameter "z->Gate trigger scene NO. is [1~64,0=inactive]" (z=1~8)

This parameter is for setting scene number of logic gate forwarding. Up to 8 trigger scene number can be set for each logic. Options: **1..64, 0=inactive**

Parameter "Input A/B/C/D send on"

This parameter is for setting the output of input X (X=A/B/C/D) after gate forwarding. Options:

Output A

Output B

...

Output B,C,D

According to the options, one input can be forwarded into one or more outputs, the output value is the same as the input value.

5.7.3.Parameter window“Threshold comparator”

Description for logic function	<input type="text"/>
Function of channel	Threshold comparator ▾
Threshold value data type	1byte unsigned value (DPT5.010) ▾
Threshold value	0 ▲▼
If Object value<Threshold value	Do not send telegram ▾
If Object value=Threshold value	Do not send telegram ▾
If Object value!=Threshold value	Do not send telegram ▾
If Object value>Threshold value	Do not send telegram ▾
If Object value<=Threshold value	Do not send telegram ▾
If Object value>=Threshold value	Do not send telegram ▾
Output send when	<input checked="" type="radio"/> Receiving a new telegram <input type="radio"/> Every change of output object
Send delay time: Base	None ▾
Factor: 1..255	1 ▲▼

Fig.5.7.3 Parameter window“Threshold comparator”

Parameter“Threshold value data type”

This parameter is for setting the threshold value data type. Options:

- | | |
|--|--|
| 4bit value (DPT3.007) | 4byte unsigned value[0..4294967295] |
| 1byte unsigned value (DPT5.010) | Ext. temperature value (DPT 9.001) |
| 2byte unsigned value (DPT7.001) | Ext. humidity value (DPT 9.007) |
| 2byte signed value (DPT8.x) | Illuminance value (DPT 9.004) |
| 2byte float value (DPT9.x) | |

Parameter“Threshold value ”

This parameter is for setting threshold value, the range depends on the data type. Options:

4bit value (DPT3.007) 0..15 /1byte unsigned value (DPT5.010) 0..255 /

2byte unsigned value (DPT7.001) 0..65535 / 2byte signed value (DPT8.x) -32768..32767 /

2byte float value (DPT9.x) -670760...670760 / 4byte unsigned value[0..4294967295]

0..4294967295 /

Ext. temperature value (DPT 9.001) -20..95°C / Ext. humidity value (DPT 9.007) 0..100% /

Illuminance value (DPT 9.004) 0..65535luxv

—Parameter“Hysteresis threshold value”

This parameter is visible when object datatype is selected “2byte float value (DPT9.x)”,

“Illuminance value (DPT 9.004)”. Set the hysteresis threshold value. Options: **0..500**

Parameter“If Object value<Threshold value”

Parameter“If Object value=Threshold value”

Parameter“If Object value!=Threshold value”

Parameter“If Object value>Threshold value”

Parameter“If Object value<=Threshold value”

Parameter“If Object value>=Threshold value”

This parameter is for setting the logic result value that should be sent when threshold value less than, equal to, not equal to, greater than, less than or equal to the setting valve. When object datatype is selected “2byte float value (DPT9.x)”, can only set the object value less than or greater than threshold value. Options:

Do not send telegram

Send value "0"

Send value "1"

Do not send telegram: not consider to select this option.

Send value “0”/“1”: when condition is satisfied, send telegram 0 or1.

If there is a conflict between the setting options between parameters, the base on the value that should be sent when reach the final parameter condition. **For example: parameter “If Object**

value=Threshold value" is set to be "Send value "0" "; parameter "If Object value<=Threshold value" is set to be "Send value "1" "; when object value is equal to the threshold value, then the logic result will send "1".

Parameter "Output send when"

This parameter is for setting the condition of sending logic result. Options:

Receiving a new telegram

Every change of output object

Receiving a new telegram: every time the object received a new input value will the logic result be sent to the bus.

Every change of output object: only when logic result has changed will it be sent to the bus.

Note: when in the first time to logic algorithm, the logic result will be sent even if it has no change.

Parameter "Send delay time"

Base:	None
	0.1s
	1s
	...
	10s
	25s
Factor:	1..255

This parameter is for setting the delay time for sending the logic algorithm result to the bus. Delay time = Base x Factor, if option "None" of Base is selected, then there is no delay.

5.7.4. Parameter window "Format convert"

Description for logic function	<input type="text"/>
Function of channel	Format convert ▼
Function	2x1Bit-->1x2Bit ▼
Output send when	<input checked="" type="radio"/> Receiving a new telegram <input type="radio"/> Every change of output object

Fig.5.7.4 Parameter window "Format convert"

Parameter "Function"

This parameter is for setting the format convert type.

Options:

2x1bit-->1x2bit

8x1bit-->1x1byte

1x1byte-->1x2byte

2x1byte-->1x2byte

2x2byte-->1x4byte

1x1byte-->8x1bit

1x2byte-->2x1byte

1x4byte-->2x2byte

1x3byte-->3x1byte

3x1byte-->1x3byte

Parameter "Output send when"

This parameter is for setting the condition of sending logic result. Options:

Receiving a new telegram

Every change of output object

Receiving a new telegram: every time the object received a new input value will the logic result be sent to the bus;

Every change of output object: only when logic result has changed will it be sent to the bus.

Note: when in the first time to logic algorithm, the logic result will be sent even if it has no change.

5.7.5. Parameter window "Gate function"

Description for logic function	<input type="text"/>
Function of channel	Gate function ▼
Object type of Input/Output	1bit[On/Off] ▼
Filter function	Deactivate ▼
Value output	<input checked="" type="radio"/> Normal <input type="radio"/> Inverted
Gate object value	<input checked="" type="radio"/> Normal <input type="radio"/> Inverted
Gate status after voltage recovery	<input type="radio"/> OFF <input checked="" type="radio"/> ON
Save input signal when gate close	<input type="checkbox"/>

Fig.5.7.5 Parameter window "Gate function"

Parameter "Object type of Input/Output"

This parameter is for setting the object type of input/output. Options:

1bit[On/Off]

1byte[0..100%]

1byte[0..255]

2byte[Float]

2byte[0..65535]

—Parameter "Filter function"

This parameter is visible when "1bit[On/Off]" is selected. Set whether to filter On or Off telegram, only pass one of them or pass all. Options:

Deactivate

On filter out

Off filter out

Deactivate: Do not filter the On or Off telegrams.

On filter out: Off can pass, On cannot pass.

Off filter out: On can pass, Off cannot pass.

——Parameter“Value output”

This parameter is visible when “1bit[On/Off]” is selected. Set whether to invert the value then output it. Options:

Normal

Inverted

——Parameter“Gate object value”

This parameter is for setting whether to invert the gate object value then output it. Options:

Normal

Inverted

——Parameter“Gate status after voltage recovery”

This parameter is for setting the gate status after voltage recovery. Options:

OFF

ON

——Parameter“Save input signal when gate close”

This parameter is for setting whether to save input signal on gate close.

Enable: enable to save the input, the input values received during the gate closing period are output when gate is open (whether the input value is changed or not).

Note: During the period when the gate is closed, the received filtered input values are not saved.

After the gate is opened, the valid input values received are output.

Disable: disable to save the input, the input values received during the gate closing period are ignored.

5.7.6. Parameter window "Delay function"

Description for logic function	<input type="text"/>
Function of channel	Delay function ▼
Object type of Input/Output	1bit[On/Off] ▼
Delay time [0..6500]	10 <input type="text"/> s

Fig.5.7.6 Parameter window "Delay function"

Parameter "Object type of Input/Output"

This parameter is for setting the object type of input/output. Options:

1bit[On/Off]

1byte[0..100%]

1byte[0..255]

2byte[Float]

2byte[0..65535]

Parameter "Delay time [0..6500]s"

This parameter is for setting the delay time that output object forwards the value when the input object receives the telegram. Options: **0..6500**

Note: Receive telegram again in delay time, re-timing.

5.7.7. Parameter window "Staircase lighting"

Description for logic function	<input type="text"/>
Function of channel	Staircase lighting ▼
Trigger value	1 ▼
Object type of output	<input checked="" type="radio"/> 1bit <input type="radio"/> 1byte
Duration time of staircase lighting [10..6500]	10 ▲▼ s
Send value 1 when trigger	<input type="radio"/> OFF <input checked="" type="radio"/> ON
Send value 2 after duration time	<input checked="" type="radio"/> OFF <input type="radio"/> ON
Retriggering	<input checked="" type="checkbox"/>

Fig.5.7.7 Parameter window "Staircase lighting"

Parameter "Trigger value"

This parameter is for setting the telegram value of the object "Trigger value". Options:

- 0
- 1
- 0 or 1

Parameter "Object type of output"

This parameter is for setting the object type of output. Options:

- 1bit
- 1byte

Parameter "Duration time of staircase lighting[10..6500]s"

This parameter is for setting duration time of staircase lighting after the stair light power on.

Options: **10..6500**

Parameter "Send value 1 when trigger"

Parameter "Send value 2 after duration time"

These parameters are for setting the value to send. Send value 1 when trigger, and then send

value 2 after duration time. Options display according to the output object datatype.

When 1 bit, options:

OFF

ON

When 1 byte , options: **0..255**

Parameter "Retriggering"

This parameter is for setting whether to trigger re-timing when received trigger value in delay time.

5.8.Parameter window“Scene Group function”

Scene Group 1 Function	<input checked="" type="checkbox"/>
Scene Group 2 Function	<input type="checkbox"/>
Scene Group 3 Function	<input type="checkbox"/>
Scene Group 4 Function	<input type="checkbox"/>
Scene Group 5 Function	<input type="checkbox"/>
Scene Group 6 Function	<input type="checkbox"/>
Scene Group 7 Function	<input type="checkbox"/>
Scene Group 8 Function	<input type="checkbox"/>
Output 1 Function	<input checked="" type="checkbox"/>
Output 2 Function	<input type="checkbox"/>
Output 3 Function	<input type="checkbox"/>
Output 4 Function	<input type="checkbox"/>
Output 5 Function	<input type="checkbox"/>
Output 6 Function	<input type="checkbox"/>
Output 7 Function	<input type="checkbox"/>
Output 8 Function	<input type="checkbox"/>
Description for Output 1 function	<input type="text"/>
Object type of Output 1	1bit ▾
1->Output 1 trigger scene NO. is [1~64,0=inactive]	<input type="text" value="0"/> ▾
Object value of Output 1	<input checked="" type="radio"/> 0 <input type="radio"/> 1
Delay time for sending [0..255]	<input type="text" value="0"/> ▾ *0.1s
2->Output 1 trigger scene NO. is [1~64,0=inactive]	<input type="text" value="0"/> ▾
Object value of Output 1	<input checked="" type="radio"/> 0 <input type="radio"/> 1
Delay time for sending [0..255]	<input type="text" value="0"/> ▾ *0.1s

Fig.5.8 Parameter window“Scene Group function”

Parameter “Scene Group x Function”(x=1~8)

This parameter is for setting whether to enable scene group x function, up to 8 scene groups.

Parameter "Output y Function" (y=1~8)

This parameter is for setting whether to enable output y of scene group x, up to 8 output functions for each scene group.

As 8 group functions are the same, and 8 output functions of each group as well, the following description only about one output of a group.

Parameter "Description for Output y function" (y=1~8)

This parameter is for setting the name description for output y of group x, up to input 30 characters.

Parameter "Object type of Output y" (y=1~8)

This parameter is for setting the object type of output y of group x. Options:

1bit

1byte

2byte

RGB

RGBW

——Parameter "Object datatype"

This parameter is for setting the datatype of "1byte" or "2byte".

When the datatype is "1byte", options:

1byte unsigned value

HVAC mode

When the datatype is "2byte", options:

2byte unsigned value

Temperature value

Parameter "z->Output y trigger scene NO. is [1~64,0=inactive]" (z=1~8)

This parameter is for setting the triggered scene number of output y of group x. Up to 8 triggered

scene of each output can be configured. Options: **0..64, 0=inactive**

——Parameter “Object value of Output y”

This parameter is for setting the output value, the range depends on the data type of output y.

When the datatype is “1bit”, options: **0..1**

When the datatype is “1byte-1byte unsigned value”, options: **0..255**

When the datatype is “1byte-HVAC mode”, options:

Comfort mode

Standby mode

Economy mode

Frost/heat protection

When the datatype is “2byte-2byte unsigned value”, options: **0..65535**

When the datatype is “2byte-Temperature value”, options:

-5°C

-4°C

...

45°C

——Parameter “RGB value of Output y”

When the datatype is “RG”B or “RGBW”, this parameter is for setting the output value of RGB.

Options: **#000000..#FFFFFF**

——Parameter “White value of Output y”

When the datatype is “RGBW”, this parameter is for setting the output value of white.

Options: **0..255**

——Parameter “Delay time for sending [0..255]”

This parameter is for setting the delay time for sending the output value to the bus.

Options: **0..255 *0.1s**

Chapter 6 Description of Communication Object

The communication object is the medium to communicate other device on the bus, namely only the communication object can communicate with the bus.

NOTE: “C” in “Flag” column in the below table means enable the communication function of the object; “W” means value of object can be written from the bus; “R” means the value of the object can be read by the other devices; “T” means the object has the transmission function; “U” means the value of the object can be updated.

6.1. “General” Communication Object

Number	Name	Object Function	Description	Group Address	Length	C	R	W	T	U	Data Type	Priority
1	General	In operation			1 bit	C	R	-	T	-	switch	Low
2	General	Date			3 bytes	C	-	W	T	U	date	Low
3	General	Time			3 bytes	C	-	W	T	U	time of day	Low
4	General	Screen&LED brightness			1 byte	C	-	W	-	-	percentage (0..100%)	Low
224	Extension function	Panel locking			1 bit	C	-	W	-	-	enable	Low
226	Extension function	Night mode			1 bit	C	-	W	T	U	day/night	Low
228	Extension function	Dis/En Proximity function			1 bit	C	-	W	-	-	enable	Low
230	Extension function	Proximity output			1 bit	C	-	-	T	-	switch	Low
231	Extension function	Alarm acknowledge			1 bit	C	-	-	T	-	acknowledge	Low
233	Extension function	Alarm input			1 bit	C	-	W	T	U	alarm	Low
234	Extension function	Locking scene			1 byte	C	-	-	T	-	scene number	Low
236	Extension function	Colorful strip trigger			1 bit	C	-	W	-	-	trigger	Low
237	Extension function	Colorful strip setting			3 bytes	C	-	W	-	-	RGB value 3x(0..255)	Low
238	Extension function	Colorful strip flashing			1 bit	C	-	W	-	-	trigger	Low
239	Extension function	Colorful strip work mode			1 byte	C	-	W	-	-	counter pulses (0..255)	Low
240	Extension function	Colorful strip brightness, relative			4 bit	C	-	W	-	-	dimming control	Low
241	Extension function	Colorful strip brightness, absolute			1 byte	C	-	W	-	-	percentage (0..100%)	Low
242	Extension function	Colorful strip setting, Red			1 byte	C	-	W	-	-	percentage (0..100%)	Low
243	Extension function	Colorful strip setting, Green			1 byte	C	-	W	-	-	percentage (0..100%)	Low
244	Extension function	Colorful strip setting, Blue			1 byte	C	-	W	-	-	percentage (0..100%)	Low
245	Extension function	Colorful strip scene preset			1 bit	C	-	W	-	-	start/stop	Low
246	Extension function	Dis/En Touch tone			1 bit	C	-	W	-	-	enable	Low
247	Extension function	Dis/En Page switchover indication			1 bit	C	-	W	-	-	enable	Low
248	Extension function	UI theme switchover			1 bit	C	-	W	-	-	switch	Low
249	Screensaver-Items 1 - ...	1bit value			1 bit	C	-	W	T	U	switch	Low

Fig.6.1 “General” Communication Object

NO.	Object Function	Name	Data Type	Flag	DPT
1	In operation	General	1bit	C,R,T	1.001 switch

The communication object is used to periodically send a telegram “1” to the bus to indicate this device in normal operation. The period is set by the parameter.

4	Screen brightness	General	1byte	C,W	5.001 percentage(0..100%)
<p>The communication object is used to modify the brightness of current mode. For example, if current is normal mode, it is only updated the brightness in normal mode, while night mode it is still determined to its parameter. Note: brightness in screen saver can not be modified via the object.</p> <p>Brightness range: 10~100%, when telegram is below 10%, output 10% directly.</p>					
224	Panel locking	Extension function	1bit	C,W	1.003 enable
<p>The communication object is used to lock the panel. After screen is locked, the operation on the panel will not be responded, but can still receive the bus telegram. Telegram value is defined by the parameter.</p>					
225	Screen on/off	Extension function	1bit	C,W	1.001 switch
<p>The communication object is used to receive the telegrams from bus to control screen on/off.</p> <p>Telegram value:</p> <p style="padding-left: 40px;">0—Off</p> <p style="padding-left: 40px;">1—On</p>					
226	Night mode	Extension function	1bit	C,R,T C,W,T,U	1.024 day/night
<p>This communication object is used to send day/night status to the bus. Telegram value:</p> <p style="padding-left: 40px;">0 — Day</p> <p style="padding-left: 40px;">1 — Night</p> <p>The object flag is C,R,T when the day/night status is switched according to the time point or sunrise and sunset time, can not receive the telegram value via bus to switch;</p> <p>The object flag is C,W,T,U when the day/night status is switched according to the object, receive the telegram value via bus to switch. If device restart, the object sends status request telegram.</p>					

228	Dis/En Proximity function	Extension function	1bit	C,W	1.003 enable
The communication object is used to enable/disable proximity function.					
229	Proximity input	Extension function	1bit	C,W	1.001 switch
The communication object is visible when proximity function is triggered by the object. Receive the telegram value from bus: 1—Trigger proximity function 0—No available					
230	Proximity output	Extension function	1bit 1byte 2byte	C,T	1.001 switch 5.010 counter pulses 17.001 scene number 5.001 percentage 7.001 pulses
The communication object is determined by the parameter “Object type of output value”. When proximity function is triggered, the object can send the parameter setting value(1byte/2byte) or ON(1bit) to the bus separately. The range of value is determined by the selected data type.					
231	Alarm acknowledge	Extension function	1bit	C,T	1.016 acknowledge
When the user acknowledges the warning message on the screen, the communication object sends an acknowledge telegram to the bus, and the telegram value is 1.					
232	Alarm message	Extension function	14byte	C,W	16.001 character string (ISO 8859-1)
The communication object is used to receive the warning message displayed on the screen from bus. When no value is received initially, the warning pop-up is displayed empty.					
233	Alarm input	Extension function	1bit	C,W,T,U	1.005 alarm
The communication object is used to receive the alarm signal from bus.					

Telegram value:

0 — No alarm

1 — Alarm

If device restart, the object sends status request telegram.

234	Locking scene	Extension function	1byte	C,T	17.001 scene number
The communication object is visible when panel locking function and external scene function are enabled. Used to recall external scene command.					
235	Screen off scene	Extension function	1byte	C,T	17.001 scene number
The communication object is visible when screen off and external scene function are enabled. Used to recall external scene command.					
236	Colorful strip trigger	Extension function	1bit	C,W	1.017 trigger
The communication object is visible when colorful strip function are enabled. Used to trigger the indication function of the colorful strip via the bus.					
237	Colorful strip setting	Extension function	3byte	C,W	232.600 RGB value 3x(0..255)
This communication object is visible when colorful strip is set to "Receive 1x3byte value". Used to receive a 3byte value on the bus.					
238	Colorful strip flashing	Extension function	1bit	C,W	1.017 trigger
The communication object is visible when flashing function are enabled. Used to trigger the flashing function of the colorful strip via the bus.					
239	Colorful strip work mode	Extension function	1byte	C,W	5.010 counter pulses
The communication object is visible when colorful strip function are enabled. Used to change the work mode of colorful strip via the bus.					

Telegram value:

- 0 — Permanent on
- 1 — Slowly breathing
- 2 — Colour range cycle

240	Colorful strip brightness, relative	Extension function	4bit	C,W	3.007 dimming
241	Colorful strip brightness, absolute	Extension function	1byte	C,W	5.001 percentage(0..100%)

These two communication objects are visible when colorful strip function are enabled. Used to relative dimming or absolute adjust the current mode's brightness of colorful strip via the bus.

For example, if current is normal mode, it is only updated the brightness in normal mode, while night mode it is still determined to its parameter.

242	Colorful strip setting, Red	Extension function	1byte	C,W	5.001 percentage(0..100%)
243	Colorful strip setting, Green	Extension function	1byte	C,W	5.001 percentage(0..100%)
244	Colorful strip setting, Blue	Extension function	1byte	C,W	5.001 percentage(0..100%)

This communication object is visible when colorful strip is set to "Receive 3x1byte value". Used to receive three 1byte values on the bus.

245	Colorful strip scene preset	Extension function	1bit	C,W	1.010 start/stop
-----	--	---------------------------	-------------	------------	-------------------------

The communication object is visible when colorful strip scene function are enabled. Used to recall colorful strip scene via the bus.

Telegram value:					
0 — Return to normal setting					
1 — Recall scene					
241	Temperature value	Screensaver-Items 1 - {...}	2byte	C,W,T,U	9.001 temperature
	Humidity value		2byte		9.007 humidity
	1bit value		1bit		1.001 switch
	1byte percent value		1byte		5.001 percentage(0..100%)
	1byte unsigned value		1byte		5.010 counter pulses
	2byte unsigned value		2byte		7.001 pulses
	2byte float value		2byte		9.x float value
	4byte unsigned value		4byte		12.001 counter pulses
	4byte float value		4byte		14.x float value
	14byte value		14byte		16.001 character string (ISO 8859-1)
<p>The communication object is used to receive the corresponding value from the bus and update it to the display. Object datatype and telegram range are determined by the parameter setting.</p> <p>The name in parentheses changes with the parameter "Description...". If description is empty, display "Screensaver-Items 1 -" by default.</p>					
648	Dis/En Touch tone	Extension function	1bit	C,W	1.003 enable
<p>This communication object is used to enable/disable touch tone. When enabled, it defaults to the last configured touch tone type.</p>					

Table6.1 "General" Communication Object

6.2. "Internal sensor measurement" Communication Object

Number	Name	Object Function	Description	Group Address	Length	C	R	W	T	U	Data Type	Priority
5	Internal sensor	Temperature value			2 bytes	C	R	-	T	-	temperature (°C)	Low
6	Internal sensor	Low temperature alarm			1 bit	C	R	-	T	-	alarm	Low
7	Internal sensor	High temperature alarm			1 bit	C	R	-	T	-	alarm	Low
8	Internal sensor	Humidity value			2 bytes	C	R	-	T	-	humidity (%)	Low
9	Internal sensor	Low humidity alarm			1 bit	C	R	-	T	-	alarm	Low
10	Internal sensor	High humidity alarm			1 bit	C	R	-	T	-	alarm	Low

Fig.6.2 "Internal sensor measurement" Communication Object

NO.	Object Function	Name	Data Type	Flag	DPT
5	Temperature value	Internal sensor	2byte	C,R,T	9.001 temperature
The communication object is used for transmitting the temperature value detected by the built-in temperature sensor of the device to the bus. Range:-50~99.8°C					
6	Low temperature alarm	Internal sensor	1bit	C,R,T	1.005 alarm
The communication object is used to send the low temperature alarm signal to bus, when temperature lower than low threshold that defined by parameter.					
7	High temperature alarm	Internal sensor	1bit	C,R,T	1.005 alarm
The communication object is used to send the high temperature alarm signal to bus, when temperature higher than high threshold that defined by parameter.					
8	Humidity value	Internal sensor	2byte	C,R,T	9.007 humidity
The communication object is used to receive humidity measurements sent from the humidity sensor on the bus. Range:0~100%					
9	Low humidity alarm	Internal sensor	1bit	C,R,T	1.005 alarm
The communication object is used to send the low humidity alarm signal to bus, when humidity lower than low threshold that defined by parameter.					
10	High humidity alarm	Internal sensor	1bit	C,R,T	1.005 alarm
The communication object is used to send the high humidity alarm signal to bus, when humidity higher than high threshold that defined by parameter.					

Table6.2 "Internal sensor measurement" Communication Object

6.3. "Button" Communication Object

6.3.1. Individual/Rocker button

The objects of individual button are similar to the rocker button, so the repeat objects as follow are explained by individual button.

Number	Name	Object Function	Description	Group Address	Length	C	R	W	T	U	Data Type	Priority
268	Page 1 - Button 1 - ...	Disable			1 bit	C	-	W	-	-	enable	Low
269	Page 1 - Button 1 - ...	Switch			1 bit	C	-	-	T	-	switch	Low
272	Page 1 - Button 1 - ...	Flashing function			1 bit	C	-	W	-	U	enable	Low
274	Page 1 - Button 1 - ...	Switch status			1 bit	C	-	W	T	U	switch	Low
Number	Name	Object Function	Description	Group Address	Length	C	R	W	T	U	Data Type	Priority
268	Page 1 - Button 1 - ...	Disable			1 bit	C	-	W	-	-	enable	Low
269	Page 1 - Button 1 - ...	Press, Switch			1 bit	C	-	-	T	-	switch	Low
270	Page 1 - Button 1 - ...	Release, Switch			1 bit	C	-	-	T	-	switch	Low
272	Page 1 - Button 1 - ...	Flashing function			1 bit	C	-	W	-	U	enable	Low
274	Page 1 - Button 1 - ...	Press, Switch status			1 bit	C	-	W	T	U	switch	Low
275	Page 1 - Button 1 - ...	Release, Switch status			1 bit	C	-	W	T	U	switch	Low
Number	Name	Object Function	Description	Group Address	Length	C	R	W	T	U	Data Type	Priority
268	Page 1 - Button 1 - ...	Disable			1 bit	C	-	W	-	-	enable	Low
269	Page 1 - Button 1 - ...	Short, Switch			1 bit	C	-	-	T	-	switch	Low
270	Page 1 - Button 1 - ...	Long, Switch			1 bit	C	-	-	T	-	switch	Low
272	Page 1 - Button 1 - ...	Flashing function			1 bit	C	-	W	-	U	enable	Low
274	Page 1 - Button 1 - ...	Short, Switch status			1 bit	C	-	W	T	U	switch	Low
275	Page 1 - Button 1 - ...	Long, Switch status			1 bit	C	-	W	T	U	switch	Low

Switch

Number	Name	Object Function	Description	Group Address	Length	C	R	W	T	U	Data Type	Priority
268	Page 1 - Button 1 - ...	Disable			1 bit	C	-	W	-	-	enable	Low
269	Page 1 - Button 1 - ...	Short, Switch			1 bit	C	-	-	T	-	switch	Low
270	Page 1 - Button 1 - ...	Long, Dimming			4 bit	C	-	W	T	-	dimming control	Low
272	Page 1 - Button 1 - ...	Flashing function			1 bit	C	-	W	-	U	enable	Low
274	Page 1 - Button 1 - ...	Switch status			1 bit	C	-	W	T	U	switch	Low

Dimming

Number	Name	Object Function	Description	Group Address	Length	C	R	W	T	U	Data Type	Priority
268	Page 1 - Button 1 - ...	Disable			1 bit	C	-	W	-	-	enable	Low
269	Page 1 - Button 1 - ...	Switch			1 bit	C	-	-	T	-	switch	Low
270	Page 1 - Button 1 - ...	RGB dimming value			3 bytes	C	-	-	T	-	RGB value 3x(0..255)	Low
274	Page 1 - Button 1 - ...	Switch status			1 bit	C	-	W	T	U	switch	Low

1x3byte

Number	Name	Object Function	Description	Group Address	Length	C	R	W	T	U	Data Type	Priority
268	Page 1 - Button 1 - ...	Disable			1 bit	C	-	W	-	-	enable	Low
269	Page 1 - Button 1 - ...	Switch			1 bit	C	-	-	T	-	switch	Low
270	Page 1 - Button 1 - ...	Red dimming value			1 byte	C	-	-	T	-	percentage (0..100%)	Low
271	Page 1 - Button 1 - ...	Green dimming value			1 byte	C	-	-	T	-	percentage (0..100%)	Low
272	Page 1 - Button 1 - ...	Blue dimming value			1 byte	C	-	-	T	-	percentage (0..100%)	Low
274	Page 1 - Button 1 - ...	Switch status			1 bit	C	-	W	T	U	switch	Low

3x1byte RGB switching/send value

Number	Name	Object Function	Description	Group Address	Length	C	R	W	T	U	Data Type	Priority
268	Page 1 - Button 1 - ...	Disable			1 bit	C	-	W	-	-	enable	Low
269	Page 1 - Button 1 - ...	Switch			1 bit	C	-	-	T	-	switch	Low
270	Page 1 - Button 1 - ...	RGB dimming value			3 bytes	C	-	-	T	-	RGB value 3x(0..255)	Low
274	Page 1 - Button 1 - ...	Switch status			1 bit	C	-	W	T	U	switch	Low
275	Page 1 - Button 1 - ...	RGB brightness, status			3 bytes	C	-	W	T	U	RGB value 3x(0..255)	Low

1x3byte

Number	Name	Object Function	Description	Group Address	Length	C	R	W	T	U	Data Type	Priority
268	Page 1 - Button 1 - ...	Disable			1 bit	C	-	W	-	-	enable	Low
269	Page 1 - Button 1 - ...	Switch			1 bit	C	-	-	T	-	switch	Low
270	Page 1 - Button 1 - ...	Hue(H) dimming value			1 byte	C	-	-	T	-	angle (degrees)	Low
271	Page 1 - Button 1 - ...	Saturation(S) dimming value			1 byte	C	-	-	T	-	percentage (0..100%)	Low
272	Page 1 - Button 1 - ...	Value(V) dimming value			1 byte	C	-	-	T	-	percentage (0..100%)	Low
274	Page 1 - Button 1 - ...	Switch status			1 bit	C	-	W	T	U	switch	Low
275	Page 1 - Button 1 - ...	Hue(H) brightness, status			1 byte	C	-	W	T	U	angle (degrees)	Low
276	Page 1 - Button 1 - ...	Saturation(S) brightness, status			1 byte	C	-	W	T	U	percentage (0..100%)	Low
277	Page 1 - Button 1 - ...	Value(V) brightness, status			1 byte	C	-	W	T	U	percentage (0..100%)	Low

3x1byte(HSV) RGB dimming

Number	Name	Object Function	Description	Group Address	Length	C	R	W	T	U	Data Type	Priority
268	Page 1 - Button 1 - ...	Disable			1 bit	C	-	W	-	-	enable	Low
269	Page 1 - Button 1 - ...	Switch			1 bit	C	-	-	T	-	switch	Low
270	Page 1 - Button 1 - ...	RGBW dimming value			6 bytes	C	-	-	T	-	RGBW value 4x(0..100%)	Low
274	Page 1 - Button 1 - ...	Switch status			1 bit	C	-	W	T	U	switch	Low

1x6byte

Number	Name	Object Function	Description	Group Address	Length	C	R	W	T	U	Data Type	Priority
268	Page 1 - Button 1 - ...	Disable			1 bit	C	-	W	-	-	enable	Low
269	Page 1 - Button 1 - ...	Switch			1 bit	C	-	-	T	-	switch	Low
270	Page 1 - Button 1 - ...	Red dimming value			1 byte	C	-	-	T	-	percentage (0..100%)	Low
271	Page 1 - Button 1 - ...	Green dimming value			1 byte	C	-	-	T	-	percentage (0..100%)	Low
272	Page 1 - Button 1 - ...	Blue dimming value			1 byte	C	-	-	T	-	percentage (0..100%)	Low
273	Page 1 - Button 1 - ...	White dimming value			1 byte	C	-	-	T	-	percentage (0..100%)	Low
274	Page 1 - Button 1 - ...	Switch status			1 bit	C	-	W	T	U	switch	Low

4x1byte

RGBW switching/send value

Number	Name	Object Function	Description	Group Address	Length	C	R	W	T	U	Data Type	Priority
268	Page 1 - Button 1 - ...	Disable			1 bit	C	-	W	-	-	enable	Low
269	Page 1 - Button 1 - ...	Switch			1 bit	C	-	-	T	-	switch	Low
270	Page 1 - Button 1 - ...	RGBW dimming value			6 bytes	C	-	-	T	-	RGBW value 4x(0..100...	Low
274	Page 1 - Button 1 - ...	Switch status			1 bit	C	-	W	T	U	switch	Low
275	Page 1 - Button 1 - ...	RGBW brightness, status			6 bytes	C	-	W	T	U	RGBW value 4x(0..100...	Low

1x6byte

Number	Name	Object Function	Description	Group Address	Length	C	R	W	T	U	Data Type	Priority
268	Page 1 - Button 1 - ...	Disable			1 bit	C	-	W	-	-	enable	Low
269	Page 1 - Button 1 - ...	Switch			1 bit	C	-	-	T	-	switch	Low
270	Page 1 - Button 1 - ...	Red dimming value			1 byte	C	-	-	T	-	percentage (0..100%)	Low
271	Page 1 - Button 1 - ...	Green dimming value			1 byte	C	-	-	T	-	percentage (0..100%)	Low
272	Page 1 - Button 1 - ...	Blue dimming value			1 byte	C	-	-	T	-	percentage (0..100%)	Low
273	Page 1 - Button 1 - ...	White dimming value			1 byte	C	-	-	T	-	percentage (0..100%)	Low
274	Page 1 - Button 1 - ...	Switch status			1 bit	C	-	W	T	U	switch	Low
275	Page 1 - Button 1 - ...	Red brightness, status			1 byte	C	-	W	T	U	percentage (0..100%)	Low
276	Page 1 - Button 1 - ...	Green brightness, status			1 byte	C	-	W	T	U	percentage (0..100%)	Low
277	Page 1 - Button 1 - ...	Blue brightness, status			1 byte	C	-	W	T	U	percentage (0..100%)	Low
278	Page 1 - Button 1 - ...	White brightness, status			1 byte	C	-	W	T	U	percentage (0..100%)	Low

4x1byte(RGBW)

Number	Name	Object Function	Description	Group Address	Length	C	R	W	T	U	Data Type	Priority
268	Page 1 - Button 1 - ...	Disable			1 bit	C	-	W	-	-	enable	Low
269	Page 1 - Button 1 - ...	Switch			1 bit	C	-	-	T	-	switch	Low
270	Page 1 - Button 1 - ...	Hue(H) dimming value			1 byte	C	-	-	T	-	angle (degrees)	Low
271	Page 1 - Button 1 - ...	Saturation(S) dimming value			1 byte	C	-	-	T	-	percentage (0..100%)	Low
272	Page 1 - Button 1 - ...	Value(V) dimming value			1 byte	C	-	-	T	-	percentage (0..100%)	Low
273	Page 1 - Button 1 - ...	White dimming value			1 byte	C	-	-	T	-	percentage (0..100%)	Low
274	Page 1 - Button 1 - ...	Switch status			1 bit	C	-	W	T	U	switch	Low
275	Page 1 - Button 1 - ...	Hue(H) brightness, status			1 byte	C	-	W	T	U	angle (degrees)	Low
276	Page 1 - Button 1 - ...	Saturation(S) brightness, status			1 byte	C	-	W	T	U	percentage (0..100%)	Low
277	Page 1 - Button 1 - ...	Value(V) brightness, status			1 byte	C	-	W	T	U	percentage (0..100%)	Low
278	Page 1 - Button 1 - ...	White brightness, status			1 byte	C	-	W	T	U	percentage (0..100%)	Low

4x1byte(HSVW) RGBW dimming

Number	Name	Object Function	Description	Group Address	Length	C	R	W	T	U	Data Type	Priority
268	Page 1 - Button 1 - ...	Disable			1 bit	C	-	W	-	-	enable	Low
269	Page 1 - Button 1 - ...	Switch			1 bit	C	-	-	T	-	switch	Low
270	Page 1 - Button 1 - ...	Brightness value			1 byte	C	-	-	T	-	percentage (0..100%)	Low
271	Page 1 - Button 1 - ...	Colour temperature value			2 bytes	C	-	-	T	-	absolute colour temp...	Low
274	Page 1 - Button 1 - ...	Switch status			1 bit	C	-	W	T	U	switch	Low

Colour temperature switching/send value

Number	Name	Object Function	Description	Group Address	Length	C	R	W	T	U	Data Type	Priority
268	Page 1 - Button 1 - ...	Disable			1 bit	C	-	W	-	-	enable	Low
269	Page 1 - Button 1 - ...	Switch			1 bit	C	-	-	T	-	switch	Low
270	Page 1 - Button 1 - ...	Brightness value			1 byte	C	-	-	T	-	percentage (0..100%)	Low
271	Page 1 - Button 1 - ...	Relative percentage colour temperature			1 byte	C	-	-	T	-	percentage (0..100%)	Low
274	Page 1 - Button 1 - ...	Switch status			1 bit	C	-	W	T	U	switch	Low
275	Page 1 - Button 1 - ...	Brightness value, status			1 byte	C	-	W	T	U	percentage (0..100%)	Low
276	Page 1 - Button 1 - ...	Relative percentage colour temperature, status			1 byte	C	-	W	T	U	percentage (0..100%)	Low

1byte relative percentage value

Number	Name	Object Function	Description	Group Address	Length	C	R	W	T	U	Data Type	Priority
268	Page 1 - Button 1 - ...	Disable			1 bit	C	-	W	-	-	enable	Low
269	Page 1 - Button 1 - ...	Switch			1 bit	C	-	-	T	-	switch	Low
270	Page 1 - Button 1 - ...	Brightness value			1 byte	C	-	-	T	-	percentage (0..100%)	Low
271	Page 1 - Button 1 - ...	Absolute colour temperature			2 bytes	C	-	-	T	-	absolute colour temp...	Low
274	Page 1 - Button 1 - ...	Switch status			1 bit	C	-	W	T	U	switch	Low
275	Page 1 - Button 1 - ...	Brightness value, status			1 byte	C	-	W	T	U	percentage (0..100%)	Low
276	Page 1 - Button 1 - ...	Absolute colour temperature, status			2 bytes	C	-	W	T	U	absolute colour temp...	Low

2byte absolute value

Colour temperature dimming

Number	Name	Object Function	Description	Group Address	Length	C	R	W	T	U	Data Type	Priority
268	Page 1 - Button 1 - ...	Disable			1 bit	C	-	W	-	-	enable	Low
269	Page 1 - Button 1 - ...	Switch			1 bit	C	-	-	T	-	switch	Low
271	Page 1 - Button 1 - ...	Absolute colour temperature			2 bytes	C	-	-	T	-	absolute colour temp...	Low
274	Page 1 - Button 1 - ...	Switch status			1 bit	C	-	W	T	U	switch	Low
276	Page 1 - Button 1 - ...	Absolute colour temperature, status			2 bytes	C	-	W	T	U	absolute colour temp...	Low

Colour temperature adjustment

Number	Name	Object Function	Description	Group Address	Length	C	R	W	T	U	Data Type	Priority
268	Page 1 - Button 1 - ...	Disable			1 bit	C	-	W	-	-	enable	Low
269	Page 1 - Button 1 - ...	Short, 1bit value			1 bit	C	-	-	T	-	switch	Low

Value sender

Number	Name	Object Function	Description	Group Address	Length	C	R	W	T	U	Data Type	Priority
268	Page 1 - Button 1 - ...	Disable			1 bit	C	-	W	-	-	enable	Low
269	Page 1 - Button 1 - ...	Scene			1 byte	C	-	-	T	-	scene control	Low
Number	Name	Object Function	Description	Group Address	Length	C	R	W	T	U	Data Type	Priority
268	Page 1 - Button 1 - ...	Disable			1 bit	C	-	W	-	-	enable	Low
269	Page 1 - Button 1 - ...	Short, Scene			1 byte	C	-	-	T	-	scene control	Low
270	Page 1 - Button 1 - ...	Long, Scene			1 byte	C	-	-	T	-	scene control	Low

Scene control

Number	Name	Object Function	Description	Group Address	Length	C	R	W	T	U	Data Type	Priority
268	Page 1 - Button 1 - ...	Disable			1 bit	C	-	W	-	-	enable	Low
269	Page 1 - Button 1 - ...	Up/Down, Blind			1 bit	C	-	W	T	-	up/down	Low
270	Page 1 - Button 1 - ...	Stop/Adjust, Blind			1 bit	C	-	W	T	-	step	Low
272	Page 1 - Button 1 - ...	Flashing function			1 bit	C	-	W	-	U	enable	Low

Blind

Number	Name	Object Function	Description	Group Address	Length	C	R	W	T	U	Data Type	Priority
268	Page 1 - Button 1 - ...	Disable			1 bit	C	-	W	-	-	enable	Low
269	Page 1 - Button 1 - ...	Register value			1 byte	C	-	W	T	U	counter pulses (0..255)	Low

Shift register

Number	Name	Object Function	Description	Group Address	Length	C	R	W	T	U	Data Type	Priority
268	Page 1 - Button 1 - ...	Disable			1 bit	C	-	W	-	-	enable	Low
269	Page 1 - Button 1 - ...	Object1-On/Off			1 bit	C	-	W	T	-	switch	Low
270	Page 1 - Button 1 - ...	Object2-On/Off			1 bit	C	-	W	T	-	switch	Low
271	Page 1 - Button 1 - ...	Object3-On/Off			1 bit	C	-	W	T	-	switch	Low
272	Page 1 - Button 1 - ...	Object4-On/Off			1 bit	C	-	W	T	-	switch	Low

Multiple operation

Number	Name	Object Function	Description	Group Address	Length	C	R	W	T	U	Data Type	Priority
268	Page 1 - Button 1 - ...	Disable			1 bit	C	-	W	-	-	enable	Low
269	Page 1 - Button 1 - ...	Short, Delay mode			1 bit	C	-	-	T	-	switch	Low
270	Page 1 - Button 1 - ...	Long, Delay mode			1 bit	C	-	-	T	-	switch	Low

Delay mode

Number	Name	Object Function	Description	Group Address	Length	C	R	W	T	U	Data Type	Priority
269	Page 1 - Button 1 - ...	Status display(2byte temperature)			2 bytes	C	-	W	T	U	temperature (°C)	Low

Status display

Number	Name	Object Function	Description	Group Address	Length	C	R	W	T	U	Data Type	Priority
268	Page 1 - Rocker 1 - ...	Disable			1 bit	C	-	W	-	-	enable	Low
269	Page 1 - Rocker 1 - ...	Current setpoint adjustment			2 bytes	C	-	-	T	-	temperature (°C)	Low
274	Page 1 - Rocker 1 - ...	Current temperature setpoint, status			2 bytes	C	-	W	T	U	temperature (°C)	Low

Setpoint adjustment(absolute)

Number	Name	Object Function	Description	Group Address	Length	C	R	W	T	U	Data Type	Priority
268	Page 1 - Rocker 1 - ...	Disable			1 bit	C	-	W	-	-	enable	Low
269	Page 1 - Rocker 1 - ...	Setpoint offset			1 bit	C	-	-	T	-	step	Low

Offset Increase/Decrease(relative)

Number	Name	Object Function	Description	Group Address	Length	C	R	W	T	U	Data Type	Priority
268	Page 1 - Rocker 1 - ...	Disable			1 bit	C	-	W	-	-	enable	Low
269	Page 1 - Rocker 1 - ...	Offset setpoint adjustment			2 bytes	C	-	-	T	-	temperature differenc...	Low
274	Page 1 - Rocker 1 - ...	Current Setpoint offset, status			2 bytes	C	-	W	T	U	temperature differenc...	Low

Offset setpoint adjustment(relative)

Setpoint adjustment

279	Page 1 - Button 1 - ...	Status display indication			1 bit	C	-	W	T	U	switch	Low
-----	-------------------------	---------------------------	--	--	-------	---	---	---	---	---	--------	-----

Status display indication

280	Page 1 - Button 1 - ...	Status LED indication			1 bit	C	-	W	T	U	switch	Low
-----	-------------------------	-----------------------	--	--	-------	---	---	---	---	---	--------	-----

Status LED indication

Fig.6.3.1“Individual/Rocker button” communication Object

NO.	Object Function	Name	Data Type	Flag	DPT
268	Disable	Page 1-Button 1 - {...}	1bit	C,W	1.003 enable

This communication object is used to the following functions. Used to disable/enable the function of contact input.

The name in parentheses changes with the parameter “Description...”. If description is empty, display “Button 1 -” by default. The same below.

269	Switch	Page 1-Button 1 - {...}	1bit	C,T	1.001 switch
269	Press/Short, Switch	Page 1-Button 1 - {...}	1bit	C,T	1.001 switch
270	Release/Long, Switch	Page 1-Button 1 - {...}	1bit	C,T	1.001 switch
274	Switch status	Page 1-Button 1 - {...}	1bit	C,W,T,U	1.001 switch
274	Press/Short, Switch status	Page 1-Button 1 - {...}	1bit	C,W,T,U	1.001 switch
275	Release/Long, Switch status	Page 1-Button 1 - {...}	1bit	C,W,T,U	1.001 switch

These communication objects are used to trigger a switching operation. Use a common object or two separate objects is according to the parameter setting when press/release and long/short operation.

Only "Switch" and "Switch status" are visible when use a common object. If use two separate objects, "Press/Release" is visible when there is no distinction for short/long operation; "Short/Long" is visible when there is distinction for short/long operation. Telegrams:

0—OFF

1—ON

Obj.269/Obj.270: used to send telegrams of switch control to the bus.

Obj.274/Obj.275: used to receive the feedback of switch status from the bus. If device restart, the object sends status request telegram.

269	Short, Switch	Page 1-Button 1 - {...}	1bit	C,T	1.001 switch
270	Long, Dimming	Page 1-Button 1 - {...}	4bit	C,W,T	3.007 dimming
274	Switch status	Page 1-Button 1 - {...}	1bit	C,W,T,U	1.001 switch

These communication objects are used to switch/dimming operation, with distinction for long/short operation.

Obj.269、 Obj.274: as the same as above.

Obj.270: used to trigger a relative dimming operation.

Dimming down when telegram of object “Long, Dimming” is 1~7, and the larger this range the adjust step is smaller. That is, the maximum step of dimming down when is 1, and the minimum step of dimming down when is 7, stop dimming when is 0;

Dimming up when telegram is 9~15, and the larger this range the adjust step is smaller. That is, the maximum step of dimming up when is 9, and the minimum step of dimming up when is 15, stop dimming when is 8.

269	Switch	Page 1-Button 1 - {...}	1bit	C,T	1.001 switch
270	RGB dimming value	Page 1-Button 1 - {...}	3byte	C,T	232.600 RGB value 3x(0..255)
274	Switch status	Page 1-Button 1 - {...}	1bit	C,W,T,U	1.001 switch
275	RGB brightness, status	Page 1-Button 1 - {...}	3byte	C,W,T,U	232.600 RGB value 3x(0..255)

These communication objects are used for RGB switching/send value, and RGB dimming.

Obj.269, Obj.274: as the same as above.

When RGB object type is selected 1x3byte, Obj.270 and Obj.275 are visible:

Obj.270: only visible when 1x3byte for the RGB object type, used to send brightness value of RGB three-colour lamp to the bus.

Obj.275: only visible when dimming function and 1x3byte for the RGB object type, used to receive brightness telegram of RGB three-colour lamp from bus.

3-Byte Code for RGB Dimming Object Data Type: U8 U8 U8, as follows:

3 _{MSB}	2	1 _{LSB}
R	G	B
UUUUUUUU	UUUUUUUU	UUUUUUUU

R: red dimming value; G: green dimming value; B: blue dimming value.

270	Hue(H) dimming value	Page 1-Button 1 - {...}	1byte	C,T	5.003 angle(degrees)
271	Saturation(S) dimming value	Page 1-Button 1 - {...}	1byte	C,T	5.001 percentage(0..100%)
272	Value(V) dimming value	Page 1-Button 1 - {...}	1byte	C,T	5.001 percentage(0..100%)

275	Hue(H) brightness, status	Page 1-Button 1 - {...}	1byte	C,W,T,U	5.003 angle(degrees)
276	Saturation(S) brightness, status	Page 1-Button 1 - {...}	1byte	C,W,T,U	5.001 percentage(0..100%)
277	Value(V) brightness, status	Page 1-Button 1 - {...}	1byte	C,W,T,U	5.001 percentage(0..100%)

These communication objects are visible when dimming function and 3x1byte(HSV) for the RGB object type or 4x1byte(HSVW) for the RGBW.

Obj.270/271/272: used to send Hue(H)/Saturation(S)/Value(V) to the bus.

Obj.275/276/277: used to receive Hue(H)/Saturation(S)/Value(V) telegram from bus.

269	Switch	Page 1-Button 1 - {...}	1bit	C,T	1.001 switch
270	RGBW dimming value	Page 1-Button 1 - {...}	6byte	C,T	251.600 DPT_Colour_RGBW
274	Switch status	Page 1-Button 1 - {...}	1bit	C,W,T,U	1.001 switch
275	RGBW brightness, status	Page 1-Button 1 - {...}	6byte	C,W,T,U	251.600 DPT_Colour_RGBW

These communication objects are used for RGBW switching/send value, and RGBW dimming.

Obj.269, Obj.274: as the same as above.

When RGBW object type is selected 1x6byte, Obj.270 and Obj.275 are visible:

Obj.270: used to send brightness value of RGBW four-colour lamp to the bus.

Obj.275: only visible when dimming function, used to receive brightness telegram of RGBW four-colour lamp from bus.

Encoding of the data type of the 6-byte RGBW dimming object: U8 U8 U8 U8 R8 R4 B4, as follows:

6 _{MSB}	5	4	3	2	1 _{LSB}
R	G	B	W	Reserve	r r r r mR mG mB mW
UUUUUUUU	UUUUUUUU	UUUUUUUU	UUUUUUUU	00000000	0000BBBB

R: red dimming value; G: green dimming value; B: blue dimming value; W: white dimming value;

mR: determines whether the red dimming value is valid, 0 = invalid, 1 = valid;

mG: determines whether the green dimming value is valid, 0 = invalid, 1 = valid;

mB: determines whether the blue dimming value is valid, 0 = invalid, 1 = valid;

mW: Determines whether the white dimming value is valid,0 = invalid,1 =valid.

270	Red dimming value	Page 1-Button 1 - {...}	1byte	C,T	5.001 percentage(0..100%)
271	Green dimming value	Page 1-Button 1 - {...}	1byte	C,T	5.001 percentage(0..100%)
272	Blue dimming value	Page 1-Button 1 - {...}	1byte	C,T	5.001 percentage(0..100%)
273	White dimming value	Page 1-Button 1 - {...}	1byte	C,T	5.001 percentage(0..100%)
275	Red dimming value, status	Page 1-Button 1 - {...}	1byte	C,W,T,U	5.001 percentage(0..100%)
276	Green dimming value, status	Page 1-Button 1 - {...}	1byte	C,W,T,U	5.001 percentage(0..100%)
277	Blue dimming value, status	Page 1-Button 1 - {...}	1byte	C,W,T,U	5.001 percentage(0..100%)
278	White brightness, status	Page 1-Button 1 - {...}	1byte	C,W,T,U	5.001 percentage(0..100%)

These communication objects are used for RGB and RGBW switching/send value, and dimming function.

Obj.270~Obj.272 and Obj.275~Obj.277 are visible when 3x1byte for the RGB object type or 4x1byte for the RGBW object type, Obj.273 and Obj.278 are only visible when RGBW is selected 4x1byte.Telegrams: 0...100%

Obj.270: used to send brightness value of the control R (red) channel to the bus.

Obj.271: used to send brightness value of the control G (green) channel to the bus.

Obj.272: used to send brightness value of the control B (blue) channel to the bus.

Obj.273: used to send brightness value of the control W (white) channel to the bus.

Obj.274: used to receive brightness status of the control R (red) channel from bus.

Obj.275: used to receive brightness status of the control G (green) channel from bus.

Obj.276: used to receive brightness status of the control B (blue) channel from bus.

Obj.277: only the RGB/RGBW dimming function is visible, used to receive brightness status of the control W (white) channel from bus.

269	Switch	Page 1-Button 1 - {...}	1bit	C,T	1.001 switch
270	Brightness value	Page 1-Button 1 - {...}	1byte	C,T	5.001 percentage(0..100%)
271	Colour temperature value Relative percentage colour temperature Absolute colour temperature	Page 1-Button 1 - {...}	2byte	C,T	5.001 percentage(0..100%) 7.600 absolute colour temperature
274	Switch status	Page 1-Button 1 - {...}	1bit	C,W,T,U	1.001 switch
275	Brightness value, status	Page 1-Button 1 - {...}	1byte	C,W,T,U	5.001 percentage(0..100%)
276	Relative percentage colour temperature, status Absolute colour temperature, status	Page 1-Button 1 - {...}	1byte 2byte	C,W,T,U	5.001 percentage(0..100%) 7.600 absolute colour temperature

These communication objects are used for colour temperature switching/send value, dimming function and adjustment function.

Obj.269, Obj.274: as the same as above.

Obj.270: used to send the dimming telegram of the colour temperature to the bus, that is, sending the brightness value. Telegrams: 0...100%

Obj.271: only display "Colour temperature value" when switching/send value; display "Relative percentage colour temperature" or "Absolute colour temperature" according to object type when dimming function. Only "Absolute colour temperature" when adjustment function. Used to send the control telegram of the colour temperature to the bus.

Telegrams: 1byte is 0..100% and 2byte is 2000...7000 K

Obj.275: only visible when dimming function, used to receive status of brightness value from bus.

Obj.276: when dimming function, display "Relative percentage colour temperature, status" or "Absolute colour temperature" according to object type; while adjustment function, only display "Absolute colour temperature, status". Used to receive colour temperature status from bus.

269	Short, 1bit value	Page 1-Button 1 - {{...}}	1bit	C,T	1.001 switch
	Short, 2bit value		2bit		2.001 switch control
	Short, 4bit value		4bit		3.007 dimming
	Short, 1byte value		1byte		5.010 counter pulses
	Short, 2byte value		2byte		7.001 pulses
	Short, 2byte float value		2byte		9.x float value
	Short, 4byte value		4byte		12.001 counter pulses
	Short, 4byte float value		4byte		14.x float value
270	Long, 1bit value	Page 1-Button 1 - {{...}}	1bit	C,T	1.001 switch
	Long, 2bit value		2bit		2.001 switch control
	Long, 4bit value		4bit		3.007 dimming
	Long, 1byte value		1byte		5.010 counter pulses
	Long, 2byte value		2byte		7.001 pulses
	Long, 2byte float value		2byte		9.x float value
	Long, 4byte value		4byte		12.001 counter pulses
	Long, 4byte float value		4byte		14.x float value
<p>These communication objects are used to value sender. Object type and value range are determined by the parameter setting datatype.</p> <p>Obj.269: used to send telegram to the bus when short operation.</p> <p>Obj.270: used to send telegram to the bus when long operation.</p>					
269	Scene	Page 1-Button 1 - {{...}}	1byte	C,T	18.001 scene control
269	Short, Scene	Page 1-Button 1 - {{...}}	1byte	C,T	18.001 scene control
270	Long, Scene	Page 1-Button 1 - {{...}}	1byte	C,T	18.001 scene control
<p>These communication objects are used to scene control. Use a common object or two separate objects is according to the parameter setting when long/short operation.</p> <p>Only the object "Scene" is visible when use a common object. If use two separate objects,</p>					

“Short/Long” is visible when there is distinction for short/long operation. Telegrams:

Detailed 8bit the meaning of the directive.

Set up a 8bit Orders for the (Binary code): FXNNNNNN

F: '0' recall scene; '1' for storage scene;

X : 0 ;

NNNNNN: Scene number(0... 63).

As follows:

Object value	message	Description
0		Recall scene 1
1		Recall scene 2
2		Recall scene 3
...		...
63		Recall scene 64
128		Store scene 1
129		Store scene 2
130		Store scene 3
...		...
191		Store scene 64

Parameter setting Options are 1~64, actually communication object “Scene” corresponds to the telegram received is 0~63 . Such as parameter settings is the scene 1, communication object “Scene” sends the scene for 0.

269	Up/Down, Blind	Page 1-Button 1 - {...}	1bit	C,W,T	1.008 up/down
270	Stop/Adjust, Blind	Page 1-Button 1 - {...}	1bit	C,W,T	1.007 step

These two communication objects are used to control the blind.

Obj.269: used to control blind up/down. Telegrams:

0—Move up

1—Move up

Obj.270: used to stop curtain movement. Telegram:

1—Stop

269	Register value	Page 1-Button 1 - {...}	1byte	C,W,T,U	5.010 counter pulses 17.001 scene number 20.102 HVAC mode 5.001 percentage(0..100%)
-----	----------------	-------------------------	-------	---------	--

This communication object is used to shift register. To send the value to the bus, object type is determined by the parameter setting datatype.

269	Object1-On/Off	Page 1-Button 1 - {...}	1bit	C,W,T	1.001 switch
	Object1-Up/Down		1bit	C,W,T	1.008 up/down
	Object1-SceneControl		1byte	C,T	18.001 scene control
	Object1-Percentage		1byte	C,T	5.001 percentage(0..100%)
	Object1-Unsigned value		1byte	C,T	5.010 counter pulses
	Object1-String		14byte	C,T	16.001 character string (ISO 8859-1)

These communication objects are used to multiple operation, up to activate 4 objects at the same time, and operation once can send the value of 4 different datatype objects to the bus via these objects. Range of values that can be sent are determined by the datatype, and the datatype is determined by the parameter setting.

Note: 14byte is only applied to object1.

269	Short, Delay mode	Page 1-Button 1 - {...}	1bit	C,T	1.001 switch
			4bit		3.007 dimming
			1byte		5.010 counter pulses
270	Long, Delay mode	Page 1-Button 1 - {...}	1bit	C,T	1.001 switch
			4bit		3.007 dimming
			1byte		5.010 counter pulses
<p>These communication objects are used to delay mode. Range of values that can be sent are determined by the datatype, and the datatype is determined by the parameter setting.</p> <p>Obj.259: used to send telegrams of delay mode to the bus when short operation.</p> <p>Obj.260: used to send telegrams of delay mode to the bus when long operation.</p>					
269	Status display(1bit)	Page 1-Button 1 - {...}		C,W,T,U	
	Status display(1byte percentage)				1.1Switch
	Status display(1byte unsigned)				5.001 percentage(0..100%)
	Status display(2byte unsigned)				5.010 counter pulses
	Status display(2byte unsigned)				7.001 pulses
	Status display(2byte temperature)				9.001 temperature
	Status display(2byte humidity)				9.007 humidity
	Status display(2byte float)				9.x float value
	Status display(4byte unsigned)				12.001 counter pulses
	Status display(4byte float)				14.x float value
	Status display(14byte)				16.001 character string (ISO 8859-1)

The communication object is used to receive data of status display, the corresponding value obtained from bus is updated to the screen display. Object type and value range are determined by the parameter setting datatype.

269	Current setpoint adjustment	Page 1-Rocker 1 - {...}	2byte	C,T	9.001 temperature
274	Current temperature setpoint, status	Page 1-Rocker 1 - {...}	2byte	C,W,T,U	9.001 temperature

These communication objects are used to setpoint temperature adjustment, are visible when “Setpoint adjustment(absolute)” is selected.

Obj.269: used to send current setpoint temperature to the bus when button operation.

Obj.274: used to receive the current setpoint temperature. If device restart, the object sends status request telegram.

269	Setpoint offset	Page 1-Rocker 1 - {...}	1bit	C,T	1.007 step
-----	-----------------	-------------------------	------	-----	------------

This communication object is used to setpoint temperature adjustment, are visible when “Offset Increase/Decrease(relative)” is selected.

Used to send the telegrams of setpoint temperature increase/decrease to the bus when button operation. Telegrams:

0—Decrease

1—Increase

269	Offset setpoint adjustment	Page 1-Rocker 1 - {...}	2byte	C,T	9.001 temperature
274	Current Setpoint offset, status	Page 1-Rocker 1 - {...}	2byte	C,W,T,U	9.001 temperature

These communication objects are used to setpoint temperature adjustment, are visible when “Offset setpoint adjustment(relative)” is selected.

Obj.269: used to send the offset of the current setpoint adjustment to the bus when button operation.

Obj.274: used to receive the offset of the current setpoint adjustment from bus.If device restart,

the object sends status request telegram.					
272	Flashing function	Page 1-Button 1 - {...}	1bit	C,W,U	1.003 enable
This communication object is only applied to switch, dimming and blind. Used to disable/enable flashing function.					
279	Status indication	Page 1-Button 1 - {...}	1bit 1byte	C,W,T,U	1.001 switch 5.010 counter pulses 5.001 percentage(0..100%)
275	Status indication	Page 1-Rocker 1 - {...}	1bit 1byte 1byte 2byte 2byte 14byte	C,W,T,U	1.001 switch 5.010 counter pulses 5.001 percentage(0..100%) 7.600 absolute colour temperature 9.001 temperature(°C) 16.001 character string (ISO 8859-1)
This communication object is used to control the status of button function on the screen via the bus, and also can receive status feedback. Range of telegram values is determined by the datatype, and the datatype is determined by the parameter setting. If device restart, the object sends status request telegram.					
280	Status LED indication	Page 1-Button 1 - {...}	1bit 1byte	C,W,T,U	1.001 switch 5.010 counter pulses 5.001 percentage(0..100%)
The communication object is visible when “Via external status object 1bit” or “Via external status object 1byte” is selected. Used to control LED status via the bus, and also can receive status feedback. Range of values that can be sent are determined by the datatype, and the datatype is determined by the parameter setting.					

Table6.3.1 “Individual/Rocker button” communication object table

6.3.2.Slap function

The objects of left buttons are similar to the right buttons, so the repeat objects as follow are explained by left buttons.

Number	Name	Object Function	Description	Group Address	Length	C	R	W	T	U	Data Type	Priority
255	Slap function	Disable			1 bit	C	-	W	-	-	enable	Low
256	Slap-left buttons - ...	Switch			1 bit	C	-	-	T	-	switch	Low
261	Slap-left buttons - ...	Switch status			1 bit	C	-	W	T	U	switch	Low

Switch

Number	Name	Object Function	Description	Group Address	Length	C	R	W	T	U	Data Type	Priority
255	Slap function	Disable			1 bit	C	-	W	-	-	enable	Low
256	Slap-left buttons - ...	Scene			1 byte	C	-	-	T	-	scene control	Low

Scene

Fig.6.3.2 "Slap function" communication Object

NO.	Object Function	Name	Data Type	Flag	DPT
255	Disable	Slap function	1bit	C,W	1.003 enable
<p>This communication object is used to the following functions. Used to disable/enable the function of contact input.</p>					
256	Switch	Slap-left buttons - {{...}}	1bit	C,T	1.001 switch
261	Switch status	Slap-left buttons - {{...}}	1bit	C,W,T,U	1.001 switch
<p>These communication objects are used to trigger a switching operation. Telegrams:</p> <p style="text-align: center;">0—Off</p> <p style="text-align: center;">1—On</p> <p>Obj.256: used to send telegrams of switch control to the bus.</p> <p>Obj.261: used to receive the feedback of switch status from the bus. If device restart, the object sends status request telegram.</p> <p>The name in parentheses changes with the parameter "Description...". If description is empty, display "Slap-left buttons -" by default. The same below.</p>					
256	Scene	Slap-left buttons - {{...}}	1byte	C,T	18.001 scene control
<p>These communication object is used to scene control.</p> <p>Set up a 8bit Orders for the (Binary code): FXNNNNNN</p>					

F: '0' recall scene; '1' for storage scene;

X : 0 ;

NNNNNN: Scene number(0... 63).

As follows:

Object value	message	Description
0		Recall scene 1
1		Recall scene 2
2		Recall scene 3
...		...
63		Recall scene 64
128		Store scene 1
129		Store scene 2
130		Store scene 3
...		...
191		Store scene 64

Parameter setting Options are 1~64, actually communication object "Scene" corresponds to the telegram received is 0~63 . Such as parameter settings is the scene 1, communication object "Scene" sends the scene for 0.

Table6.3.2 "Slap function" communication Object

6.4. "Room temperature" Communication Object

Nur	Name	Object Function	Description	Group Address	Length	C	R	W	T	U	I	Data Type	Priority
148	RTC 1 - ...	Power on/off			1 bit	C	R	W	-	-	-	switch	Low
149	RTC 1 - ...	External temperature sensor			2 bytes	C	-	W	T	U	-	temperature (°C)	Low
150	RTC 1 - ...	Base setpoint adjustment			2 bytes	C	-	W	-	-	-	temperature (°C)	Low
151	RTC 1 - ...	Setpoint offset			1 bit	C	-	W	-	-	-	step	Low
152	RTC 1 - ...	Float offset value			2 bytes	C	-	W	-	-	-	temperature difference (K)	Low
153	RTC 1 - ...	Setpoint offset reset			1 bit	C	-	W	-	-	-	reset	Low
154	RTC 1 - ...	Heating/Cooling mode			1 bit	C	-	W	-	-	-	cooling/heating	Low
155	RTC 1 - ...	Operation mode			1 byte	C	-	W	-	-	-	HVAC mode	Low
156	RTC 1 - ...	Comfort mode			1 bit	C	-	W	-	-	-	enable	Low
157	RTC 1 - ...	Economy mode			1 bit	C	-	W	-	-	-	enable	Low
158	RTC 1 - ...	Frost/Heat protection mode			1 bit	C	-	W	-	-	-	enable	Low
159	RTC 1 - ...	Standby mode			1 bit	C	-	W	-	-	-	enable	Low
160	RTC 1 - ...	Extended comfort mode			1 bit	C	-	W	-	-	-	acknowledge	Low
161	RTC 1 - ...	Fan automatic operation			1 bit	C	-	W	-	-	-	enable	Low
162	RTC 1 - ...	Window contact			1 bit	C	-	W	T	U	-	window/door	Low
163	RTC 1 - ...	Presence detector			1 bit	C	-	W	T	U	-	occupancy	Low
164	RTC 1 - ...	Actual temperature, status			2 bytes	C	R	-	T	-	-	temperature (°C)	Low
165	RTC 1 - ...	Base temperature setpoint, status			2 bytes	C	R	-	T	-	-	temperature (°C)	Low
166	RTC 1 - ...	Setpoint offset, status			2 bytes	C	R	-	T	-	-	temperature difference (K)	Low
167	RTC 1 - ...	Current temperature setpoint, status			2 bytes	C	R	-	T	-	-	temperature (°C)	Low
168	RTC 1 - ...	Heating/Cooling mode, status			1 bit	C	R	-	T	-	-	cooling/heating	Low
169	RTC 1 - ...	Operation mode, status			1 byte	C	R	-	T	-	-	HVAC mode	Low
170	RTC 1 - ...	Comfort mode, status			1 bit	C	R	-	T	-	-	enable	Low
171	RTC 1 - ...	Economy mode, status			1 bit	C	R	-	T	-	-	enable	Low
172	RTC 1 - ...	Frost/Heat protection mode, status			1 bit	C	R	-	T	-	-	enable	Low
173	RTC 1 - ...	Standby mode, status			1 bit	C	R	-	T	-	-	enable	Low
174	RTC 1 - ...	Heating control value			1 bit	C	R	-	T	-	-	switch	Low
175	RTC 1 - ...	Cooling control value			1 bit	C	R	-	T	-	-	switch	Low
176	RTC 1 - ...	Fan speed			1 byte	C	-	-	T	-	-	percentage (0..100%)	Low
177	RTC 1 - ...	Fan speed low			1 bit	C	-	-	T	-	-	switch	Low
178	RTC 1 - ...	Fan speed medium			1 bit	C	-	-	T	-	-	switch	Low
179	RTC 1 - ...	Fan speed high			1 bit	C	-	-	T	-	-	switch	Low
180	RTC 1 - ...	Fan speed off			1 bit	C	-	-	T	-	-	switch	Low
181	RTC 1 - ...	Additional heating control value			1 bit	C	R	-	T	-	-	switch	Low
182	RTC 1 - ...	Additional cooling control value			1 bit	C	R	-	T	-	-	switch	Low

Fig.6.4 "Room temperature" Communication Object

NO.	Object Function	Name	Data Type	Flag	DPT
148	Power on/off	RTC 1 - {{...}}	1bit	C,W,R	1.001 switch
<p>The communication object is used to receive the telegram from the bus to control RTC power on/off. Telegrams:</p> <p style="text-align: center;">1—On</p> <p style="text-align: center;">0—Off</p> <p>The name in parentheses changes with the parameter "Description (max 30 char.)". If description is empty, display "RTC 1 - ..." by default. The same below.</p>					

149	External temperature sensor	RTC 1 - {...}	2byte	C,W,T,U	9.001 temperature
<p>The communication object is used to receive the external temperature value detected by the temperature sensor of the device form the bus. Range:-50~99.8°C</p>					
150	Current setpoint adjustment Base setpoint adjustment	RTC 1 - {...}	2byte	C,W	9.001 temperature
<p>“Current setpoint adjustment” is visible when operation mode is not enabled, and under absolute adjustment. Used to modify the base value of the set temperature; and to modify set temperature value of current room operation mode when absolute adjustment.</p> <p>“Base setpoint adjustment” is visible only when relative adjustment, used to modify the base value of the set temperature, that is, the temperature setting value of the comfort mode, and the setting temperature of the standby mode and the economy mode changes according to the relative change. In any case, the temperature setting value of the protection mode cannot be modified by the bus.</p>					
151	Setpoint offset	RTC 1 - {...}	1bit	C,W	1.007 step
<p>The communication object is visible only when absolute adjustment, and offset function enabled. Used to adjust the offset to adjust setpoint temperature indirectly. The step value set according to the parameter. Telegrams:</p> <p style="padding-left: 40px;">1 —Increase the offset in the forward direction</p> <p style="padding-left: 40px;">0 —Decrease the offset in the negative direction</p>					
152	Float offset value	RTC 1 - {...}	2byte	C,W	9.002 temperature difference
<p>The communication object is visible only when absolute adjustment, and offset function enabled. Used to modify the accumulated offset via 2 byte float value.</p>					
153	Setpoint offset reset	RTC 1 - {...}	1bit	C,W	1.015 reset
<p>The communication object is visible only when absolute adjustment, and offset function enabled. Reset offset value when telegram is 1.</p>					

154	Heating/Cooling mode	RTC 1 - {{...}}	1bit	C,W	1.100 cooling/heating
<p>The communication object is used for switching the heating and cooling via the bus. Telegrams:</p> <p style="padding-left: 40px;">1 --Heating</p> <p style="padding-left: 40px;">0 --Cooling</p>					
155	Operation mode	RTC 1 - {{...}}	1byte	C,W	20.102 HVAC mode
<p>The communication object is visible when the “operation mode” is enabled, used to control the RTC operation mode via the bus.</p>					
156	Comfort mode	RTC 1 - {{...}}	1bit	C,W	1.003 enable
157	Economy mode	RTC 1 - {{...}}	1bit	C,W	1.003 enable
158	Frost/Heat protection mode	RTC 1 - {{...}}	1bit	C,W	1.003 enable
159	Standby mode	RTC 1 - {{...}}	1bit	C,W	1.003 enable
<p>These communication object is visible when the “operation mode” and “1-bit object function for operation mode” are enabled, used to control the RTC operation mode via the bus.</p> <p>When 1 byte: object 155 is visible, telegrams: 1-comfort, 2-standby, 3-economy, 4-protection, other reserved.</p> <p>When 1bit:</p> <p style="padding-left: 40px;">Object 156-- Comfort mode</p> <p style="padding-left: 40px;">Object 157-- Economy mode</p> <p style="padding-left: 40px;">Object 158-- Protection mode</p> <p style="padding-left: 40px;">Object 159-- Standby mode</p> <p>When the object receives the telegram “1”, the corresponding mode is activated. When 1 bit standby object is not enable, and the telegrams of comfort, economy, protection mode are 0, is standby mode. When 1 bit standby object is enable, standby object receives “1” activates standby mode, 0 is ignored.</p>					

160	Extended comfort mode	RTC 1 - {{...}}	1bit	C,W	1.016 acknowledge
<p>The communication object is visible when the "Extended comfort mode">0,it is used for triggering time to extended comfort mode. Telegrams:</p> <p style="padding-left: 40px;">1--Activate comfort mode</p> <p style="padding-left: 40px;">0--No sense</p> <p>Activate comfort mode when the object receives telegram 1. If receive again telegram 1 in delay time, time will be timed again. And return the previous operation mode from comfort mode once finish timing. If there is a new operation mode in delay time, exit the comfort mode.</p> <p>If a switch operation, exit the timing, but switch the heating/cooling will not.</p>					
161	Fan automatic operation	RTC 1 - {{...}}	1bit	C,W	1.003 enable
<p>The communication object is visible when the "fan speed auto.control function" is enabled,it is used to activate the fan automatic operation via the bus. Telegram:</p> <p style="padding-left: 40px;">1--Activate auto</p> <p style="padding-left: 40px;">0--Exit auto</p>					
162	Window contact	RTC 1 - {{...}}	1bit	C,W, T,U	1.019 Window/door
<p>The communication object is visible when the "window contact input function" is enabled,is used to receive the switch status of window contact. Telegrams:</p> <p style="padding-left: 40px;">1--The window is open</p> <p style="padding-left: 40px;">0--The window is close</p>					
163	Presence detector	RTC 1 - {{...}}	1bit	C,W, T,U	1.018 occupancy
<p>The communication object is visible when the "bus presence detector function" is enabled, is used to receive the room occupancy status from presence detector. Telegrams:</p> <p style="padding-left: 40px;">1--Occupied</p> <p style="padding-left: 40px;">0--Unoccupied</p>					

164	Actual temperature, status	RTC 1 - {{...}}	2byte	C,R,T	9.001 temperature
<p>The communication object is visible when temperature reference of RTC function is combination of internal and external sensor. Used to send the actual temperature after the combination to the bus.</p>					
165	Base temperature setpoint, status	RTC 1 - {{...}}	2byte	C,R,T	9.001 temperature
<p>The communication object is visible only when relative adjustment. Used to send the current base set temperature to the bus.</p> <p>Current base set temperature value = parameter set value (or object 150 base value)+accumulated offset value</p>					
166	Setpoint offset, status	RTC 1 - {{...}}	2byte	C,R,T	9.002 temperature difference
<p>The communication object is visible only when relative adjustment. Used to send the accumulated offset value of base set temperature to the bus.</p>					
167	Current temperature setpoint, status	RTC 1 - {{...}}	2byte	C,R,T	9.001 temperature
<p>The communication object is used to send current set temperature to the bus.</p>					
168	Heating/Cooling mode, status	RTC 1 - {{...}}	1bit	C,R,T	1.100 cooling/heating
<p>This communication object is visible when "Heating and Cooling" is selected for "Room temperature control mode";is used to feedback the telegram of switching cooling and heating function to the bus.</p>					
169	Operation mode, status	RTC 1 - {{...}}	1byte	C,R,T	20.102 HVAC mode
<p>The communication object is visible when the operation mode is enabled,it is used to send RTC operation mode status to the bus.</p>					
170	Comfort mode, status	RTC 1 - {{...}}	1bit	C,R,T	1.003 enable
171	Economy mode, status	RTC 1 - {{...}}	1bit	C,R,T	1.003 enable

172	Frost/Heat protection mode, status	RTC 1 - {{...}}	1bit	C,R,T	1.003 enable
173	Standby mode, status	RTC 1 - {{...}}	1bit	C,R,T	1.003 enable
<p>These communication objects are visible when the “operation mode” and “1-bit object function for operation mode” are enabled, used to send RTC operation mode status to the bus.</p> <p>When 1 byte: object 169 is visible, telegrams: 1-comfort, 2-standby, 3-economy, 4-protection, other reserved.</p> <p style="padding-left: 40px;">Object 170— Comfort mode</p> <p style="padding-left: 40px;">Object 171— Economy mode</p> <p style="padding-left: 40px;">Object 172— Protection mode</p> <p style="padding-left: 40px;">Object 173— Standby mode</p> <p>When a mode is activated, the corresponding object only sends telegram “1”. When 1 bit standby object is not enable, activate standby mode when comfort, economy, protection objects send telegram 0 together. When 1 bit standby object is enable, activate standby mode only when standby object send 1.</p>					
174	Heating/Cooling control value Heating control value	RTC 1 - {{...}}	1bit 1byte	C,R,T	1.001 Switch 5.001 percentage
175	Cooling control value	RTC 1 - {{...}}	1bit 1byte	C,R,T	1.001 Switch 5.001 percentage
<p>The communication object is used to send control value of heating or cooling function to the bus. Object datatype is according to parameter setting.</p>					
176	Fan speed	RTC 1 - {{...}}	1byte	C,T	5.001 percentage 5.100 fan stage
<p>The communication object is visible when the “Fan speed auto. control function” is enabled, used to send control telegrams of the fan speed to the bus.</p>					

Displayed according to the parameter “Object datatype of 1byte fan speed” option.

177	Fan speed low	RTC 1 - {...}	1bit	C,T	1.001 switch
178	Fan speed medium	RTC 1 - {...}	1bit	C,T	1.001 switch
179	Fan speed high	RTC 1 - {...}	1bit	C,T	1.001 switch
180	Fan speed off	RTC 1 - {...}	1bit	C,T	1.001 switch

These communication objects are visible when the “operation mode” and “1 bit object function for fan speed” are enabled, used to send control telegrams of the fan speed to the bus.

1bit object is visible according to the parameter setting :

Object 177—Low fan speed

Object 178—Medium fan speed

Object 179—High fan speed

Object 180—Fan speed off , are visible when “1 bit object function for fan speed off” enable.

Only the corresponding object sends telegram “1” when switch to a certain fan speed. When 1bit-off object is not enable, all objects send telegrams “0” when switch to fan speed off (The situation apply to connect with fan actuator of GVS);

When 1bit-off object is enable, only 1bit-off object send telegram “1” (The situation apply to connect with fan actuator of other manufacturers).

1byte: the corresponding telegram value of each fan speed is defined by the parameter. Activate the corresponding fan speed, and object 45 sends the corresponding telegram value of the fan speed to the bus.

181	Additional heating control value	RTC 1 - {...}	1bit	C,R,T	1.001 switch
	Additional heating/cooling control value		1byte		5.001 percentage
182	Additional cooling control value	RTC 1 - {...}	1bit	C,R,T	1.001 switch
			1byte		5.001 percentage

Object181— are visible when "Additional heating"/"Additional heating/cooling" enable.

Object182— are visible when "Additional cooling" enable.

These communication object is used to send control value of additional heating or cooling function to the bus. Object datatype is according to parameter setting.

1bit: telegrams: 1-switch on the valves, 0-switch off the valve

1byte: telegrams: 100%-switch on the valves, 0%-switch off the valve.

Table 6.4 "Room temperature" Communication Object

6.5. "Input" Communication Object

	Number	Name	Object Function	Description	Group Address	Length	C	R	W	T	U	Data Type	Priority
↕	219	Input 1 - ...	Actual temperature, Sensor			2 bytes	C	R	-	T	-	temperature (°C)	Low
↕	220	Input 1 - ...	Temperature error report, Sensor			1 bit	C	R	-	T	-	alarm	Low

Temperature probe(NTC 10K)

	Number	Name	Object Function	Description	Group Address	Length	C	R	W	T	U	Data Type	Priority
↕	218	Input 1 - ...	Disable			1 bit	C	-	W	-	-	enable	Low
↕	219	Input 1 - ...	Switch			1 bit	C	R	W	T	U	switch	Low

	Number	Name	Object Function	Description	Group Address	Length	C	R	W	T	U	Data Type	Priority
↕	218	Input 1 - ...	Disable			1 bit	C	-	W	-	-	enable	Low
↕	219	Input 1 - ...	Close, Switch			1 bit	C	R	W	T	U	switch	Low
↕	220	Input 1 - ...	Open, Switch			1 bit	C	R	W	T	U	switch	Low

	Number	Name	Object Function	Description	Group Address	Length	C	R	W	T	U	Data Type	Priority
↕	218	Input 1 - ...	Disable			1 bit	C	-	W	-	-	enable	Low
↕	219	Input 1 - ...	Short, Switch			1 bit	C	R	W	T	U	switch	Low
↕	220	Input 1 - ...	Long, Switch			1 bit	C	R	W	T	U	switch	Low

BI: Switch sensor

	Number	Name	Object Function	Description	Group Address	Length	C	R	W	T	U	Data Type	Priority
↕	218	Input 1 - ...	Disable			1 bit	C	-	W	-	-	enable	Low
↕	219	Input 1 - ...	Scene			1 byte	C	-	-	T	-	scene control	Low

	Number	Name	Object Function	Description	Group Address	Length	C	R	W	T	U	Data Type	Priority
↕	218	Input 1 - ...	Disable			1 bit	C	-	W	-	-	enable	Low
↕	219	Input 1 - ...	Close, Scene			1 byte	C	-	-	T	-	scene control	Low
↕	220	Input 1 - ...	Open, Scene			1 byte	C	-	-	T	-	scene control	Low

	Number	Name	Object Function	Description	Group Address	Length	C	R	W	T	U	Data Type	Priority
↕	218	Input 1 - ...	Disable			1 bit	C	-	W	-	-	enable	Low
↕	219	Input 1 - ...	Short, Scene			1 byte	C	-	-	T	-	scene control	Low
↕	220	Input 1 - ...	Long, Scene			1 byte	C	-	-	T	-	scene control	Low

BI: Scene control

	Number	Name	Object Function	Description	Group Address	Length	C	R	W	T	U	Data Type	Priority
↕	218	Input 1 - ...	Disable			1 bit	C	-	W	-	-	enable	Low
↕	219	Input 1 - ...	String			14 bytes	C	-	-	T	-	Character String (ISO 8859-1)	Low

	Number	Name	Object Function	Description	Group Address	Length	C	R	W	T	U	Data Type	Priority
↕	218	Input 1 - ...	Disable			1 bit	C	-	W	-	-	enable	Low
↕	219	Input 1 - ...	Close, String			14 bytes	C	-	-	T	-	Character String (ISO 8859-1)	Low
↕	220	Input 1 - ...	Open, String			14 bytes	C	-	-	T	-	Character String (ISO 8859-1)	Low

	Number	Name	Object Function	Description	Group Address	Length	C	R	W	T	U	Data Type	Priority
↕	218	Input 1 - ...	Disable			1 bit	C	-	W	-	-	enable	Low
↕	219	Input 1 - ...	Short, String			14 bytes	C	-	-	T	-	Character String (ISO 8859-1)	Low
↕	220	Input 1 - ...	Long, String			14 bytes	C	-	-	T	-	Character String (ISO 8859-1)	Low

BI: Send String(14bytes)

Fig.6.5 "Input" Communication Object

NO.	Object Function	Name	Data Type	Flag	DPT
219	Actual temperature, Sensor	Input 1 - {{...}}	2byte	C,R,T	9.001 temperature
<p>The communication object is used for transmitting the temperature value detected by the external temperature sensor of the device to the bus. Range:-50~99.8°C</p> <p>The name in parentheses changes with the parameter "Description (max 30 char.)". If description is empty, display "Input 1 - ..." by default. The same below.</p>					
220	Temperature error report, Sensor	Input 1 - {{...}}	1bit	C,R,T	1.005 alarm
<p>The communication object is used to send the error report of the external temperature sensor, and the object value is defined according to the parameters.</p>					
218	Disable	Input 1 - {{...}}	1bit	C,W	1.003 enable
<p>The communication object is used to disable/enable the function of contact input, apply to binary input function, including switch, scene and send string.</p>					
219	Switch	Input 1 - {{...}}	1bit	C,R,W,T,U	1.001 switch
219	Close/Short, Switch	Input 1 - {{...}}	1bit	C,R,W,T,U	1.001 switch
220	Open/Long, Switch	Input 1 - {{...}}	1bit	C,R,W,T,U	1.001 switch
<p>These communication objects are used to trigger a switching operation. Use a common object or two separate objects is according to the parameter setting.</p> <p>Only the object "Switch" is visible when use a common object. If use two separate objects, "Close/Open" is visible when there is no distinction for short/long operation; "Short/Long" is visible when there is distinction for short/long operation. Telegrams:</p> <p style="padding-left: 40px;">0—Off</p> <p style="padding-left: 40px;">1—On</p>					

219	Scene	Input 1 - {...}	1byte	C,T	18.001 scene control
219	Close/Short, Scene	Input 1 - {...}	1byte	C,T	18.001 scene control
220	Open/Long, Scene	Input 1 - {...}	1byte	C,T	18.001 scene control

These communication objects are used to send a 8 bit command to recall or storage scene. Use a common object or two separate objects is according to the parameter setting.

Only the object "Scene" is visible when use a common object. If use two separate objects, "Close/Open" is visible when there is no distinction for short/long operation; "Short/Long" is visible when there is distinction for short/long operation.

Detailed 8bit the meaning of the directive.

Set up a 8bit Orders for the (Binary code): FXNNNNNN

F: '0' recall scene; '1' for storage scene;

X: 0;

NNNNNN: Scene number(0... 63).

As follows:

Object message value	Description
0	Recall scene 1
1	Recall scene 2
2	Recall scene 3
...	...
63	Recall scene 64
128	Store scene 1
129	Store scene 2
130	Store scene 3
...	...
191	Store scene 64

Parameter setting Options are 1~64, actually communication object “Scene” corresponds to the telegram received is 0~63 . Such as parameter settings is the scene 1, communication object “Scene” sends the scene for 0.

219	String	Input 1 - {{...}}	14byte	C,T	16.001 character string (ISO 8859-1)
219	Close/Short, String	Input 1 - {{...}}	14byte	C,T	16.001 character string (ISO 8859-1)
220	Open/Long, String	Input 1 - {{...}}	14byte	C,T	16.001 character string (ISO 8859-1)

These communication objects are used to send the sting to bus. Use a common object or two separate objects is according to the parameter setting.

Only the object “String” is visible when use a common object. If use two separate objects, “Close/Open” is visible when there is no distinction for short/long operation; “Short/Long” is visible when there is distinction for short/long operation.

Table6.5 “Input”Communication Object

6.6. "Logic function" Communication Object

6.6.1. "AND/OR/XOR" Communication object

Number	Name	Object Function	Description	Group Address	Length	C	R	W	T	U	Data Type	Priority
11	1st Logic - ...	Input a			1 bit	C	-	W	T	U	boolean	Low
12	1st Logic - ...	Input b			1 bit	C	-	W	T	U	boolean	Low
13	1st Logic - ...	Input c			1 bit	C	-	W	T	U	boolean	Low
14	1st Logic - ...	Input d			1 bit	C	-	W	T	U	boolean	Low
15	1st Logic - ...	Input e			1 bit	C	-	W	T	U	boolean	Low
16	1st Logic - ...	Input f			1 bit	C	-	W	T	U	boolean	Low
17	1st Logic - ...	Input g			1 bit	C	-	W	T	U	boolean	Low
18	1st Logic - ...	Input h			1 bit	C	-	W	T	U	boolean	Low
19	1st Logic - ...	Logic result			1 bit	C	-	-	T	-	boolean	Low

Fig.6.6.1 "AND/OR/XOR" Communication object

NO.	Object Function	Name	Data Type	Flag	DPT
11/.../18	Input x	1st Logic - {{...}}	1bit	C,W,T,U	1.002 boolean
<p>The communication object is used to receive the value of logical input Input x.</p> <p>The name in parentheses changes with the parameter "Description for logic function". If description is empty, display "1st Logic - ..." by default. The same below.</p>					
19	Logic result	1st Logic - {{...}}	1bit	C,T	1.002 boolean
<p>The communication object is used to send the results of logical operation.</p>					

Table.6.6.1 "AND/OR/XOR" Communication object

6.6.2. "Gate forwarding" Communication object

Number	Name	Object Function	Description	Group Address	Length	C	R	W	T	U	Data Type	Priority
11	1st Logic - ...	Gate value select			1 byte	C	-	W	-	-	scene number	Low
12	1st Logic - ...	Input A			1 bit	C	-	W	-	-	switch	Low
13	1st Logic - ...	Input B			1 bit	C	-	W	-	-	switch	Low
14	1st Logic - ...	Input C			1 bit	C	-	W	-	-	switch	Low
15	1st Logic - ...	Input D			1 bit	C	-	W	-	-	switch	Low
16	1st Logic - ...	Output A			1 bit	C	-	-	T	-	switch	Low
17	1st Logic - ...	Output B			1 bit	C	-	-	T	-	switch	Low
18	1st Logic - ...	Output C			1 bit	C	-	-	T	-	switch	Low
19	1st Logic - ...	Output D			1 bit	C	-	-	T	-	switch	Low

Fig.6.6.2 "Gate forwarding" Communication object

NO.	Object Function	Name	Data Type	Flag	DPT
11	Gate value select	1st Logic - {{...}}	1byte	C,W	17.001 scene number
The communication object is used to select the scene of logical gate forwarding.					
12/.../15	Input x	1st Logic - {{...}}	1bit 4bit 1byte	C,W	1.001 switch 3.007 dimming control 5.010 counter pulses(0..255)
The communication object is used to receive the value of the logic gate input Input x.					
16/.../19	Output x	1st Logic - {{...}}	1bit 4bit 1byte	C,T	1.001 switch 3.007 dimming control 5.010 counter pulses(0..255)
The communication object is used to output the value forwarded by the logic gate. The output value is the same as the input value, but one input can be forwarded into one or more outputs, set by parameters.					

Table.6.6.2 "Gate forwarding" Communication object

6.6.3. “Threshold comparator” Communication object

Number	Name	Object Function	Description	Group Address	Length	C	R	W	T	U	Data Type	Priority
11	1st Logic - ...	Threshold value input			1 byte	C	-	W	-	U	counter pulses (0.255)	Low
19	1st Logic - ...	Logic result			1 bit	C	-	-	T	-	boolean	Low

Fig.6.6.3 “Threshold comparator” Communication object

NO.	Object Function	Name	Data Type	Flag	DPT
11	Threshold value input	1st Logic - {{...}}	4bit 1byte 2byte 4byte	C,W, U	3.007 dimming
					5.010 counter pulses
					7.001 pulses
					12.001 counter pulses
					8.x signed value
					9.x float value
					9.001 temperature
					9.007 humidity
					9.004 lux
The communication object is used to input threshold value.					
19	Logic result	1st Logic - {{...}}	1bit	C,T	1.002 boolean
The communication object is used to send the results of logical operation. That is, the value that should be sent after the object input threshold is compared with the setting threshold value.					

Table.6.6.3 “Threshold comparator” Communication object

6.6.4. "Format convert" Communication object

Number	Name	Object Function	Description	Group Address	Length	C	R	W	T	U	Data Type	Priority
11	1st Logic - ...	Input 1bit-bit0			1 bit	C	-	W	-	U	boolean	Low
12	1st Logic - ...	Input 1bit-bit1			1 bit	C	-	W	-	U	boolean	Low
19	1st Logic - ...	Output 2bit			2 bit	C	-	-	T	-	switch control	Low

"2x1bit -> 1x2bit"function: converts two 1bit values to a 2bit value, such as Input bit1=1, bit0=0->

Output 2bit=2

Number	Name	Object Function	Description	Group Address	Length	C	R	W	T	U	Data Type	Priority
11	1st Logic - ...	Input 1bit-bit0			1 bit	C	-	W	-	U	boolean	Low
12	1st Logic - ...	Input 1bit-bit1			1 bit	C	-	W	-	U	boolean	Low
13	1st Logic - ...	Input 1bit-bit2			1 bit	C	-	W	-	U	boolean	Low
14	1st Logic - ...	Input 1bit-bit3			1 bit	C	-	W	-	U	boolean	Low
15	1st Logic - ...	Input 1bit-bit4			1 bit	C	-	W	-	U	boolean	Low
16	1st Logic - ...	Input 1bit-bit5			1 bit	C	-	W	-	U	boolean	Low
17	1st Logic - ...	Input 1bit-bit6			1 bit	C	-	W	-	U	boolean	Low
18	1st Logic - ...	Input 1bit-bit7			1 bit	C	-	W	-	U	boolean	Low
19	1st Logic - ...	Output 1byte			1 byte	C	-	-	T	-	counter pulses (0..255)	Low

"8x1bit -> 1x1byte"function: converts eight 1bit values to a 1byte value, such as Input bit2=1, bit1=1, bit0=1, other bits are 0-> Output 1byte=7

Number	Name	Object Function	Description	Group Address	Length	C	R	W	T	U	Data Type	Priority
11	1st Logic - ...	Input 1byte			1 byte	C	-	W	-	U	counter pulses (0..255)	Low
19	1st Logic - ...	Output 2byte			2 bytes	C	-	-	T	-	pulses	Low

"1x1byte -> 1x2byte"function: converts one 1byte values to a 2byte value, such as Input 1byte=125->

Output 2byte=125. Although the value remains the same, the data type of the value is different.

Number	Name	Object Function	Description	Group Address	Length	C	R	W	T	U	Data Type	Priority
11	1st Logic - ...	Input 1byte-low			1 byte	C	-	W	-	U	counter pulses (0..255)	Low
12	1st Logic - ...	Input 1byte-high			1 byte	C	-	W	-	U	counter pulses (0..255)	Low
19	1st Logic - ...	Output 2byte			2 bytes	C	-	-	T	-	pulses	Low

"2x1byte -> 1x2byte"function: converts two 1byte values to a 2byte value, such as Input 1byte-low = 255 (\$FF), Input 1byte-high = 100 (\$64) -> Output 2byte = 25855 (\$64 FF)

Number	Name	Object Function	Description	Group Address	Length	C	R	W	T	U	Data Type	Priority
11	1st Logic - ...	Input 2byte-low			2 bytes	C	-	W	-	U	pulses	Low
12	1st Logic - ...	Input 2byte-high			2 bytes	C	-	W	-	U	pulses	Low
19	1st Logic - ...	Output 4byte			4 bytes	C	-	-	T	-	counter pulses (unsigned)	Low

"2x2byte -> 1x4byte"function: converts two 2 byte values to a 4byte value, such as Input 2byte-low = 65530 (\$FF FA), Input 2byte-high = 32768 (\$80 00)-> Output 2byte = 2147549178 (\$80 00 FF FA)

Number	Name	Object Function	Description	Group Address	Length	C	R	W	T	U	Data Type	Priority
11	1st Logic - ...	Input 1byte			1 byte	C	-	W	-	U	counter pulses (0..255)	Low
12	1st Logic - ...	Output 1bit-bit0			1 bit	C	-	-	T	-	boolean	Low
13	1st Logic - ...	Output 1bit-bit1			1 bit	C	-	-	T	-	boolean	Low
14	1st Logic - ...	Output 1bit-bit2			1 bit	C	-	-	T	-	boolean	Low
15	1st Logic - ...	Output 1bit-bit3			1 bit	C	-	-	T	-	boolean	Low
16	1st Logic - ...	Output 1bit-bit4			1 bit	C	-	-	T	-	boolean	Low
17	1st Logic - ...	Output 1bit-bit5			1 bit	C	-	-	T	-	boolean	Low
18	1st Logic - ...	Output 1bit-bit6			1 bit	C	-	-	T	-	boolean	Low
19	1st Logic - ...	Output 1bit-bit7			1 bit	C	-	-	T	-	boolean	Low

“1x1byte -> 8x1bit” function: converts one 1byte values to eight 1bit value, such as Input 1byte=200 -> Output bit0=0, bit1=0, bit2=0, bit3=1, bit4=0, bit5=0, bit6=1, bit7=1

Number	Name	Object Function	Description	Group Address	Length	C	R	W	T	U	Data Type	Priority
11	1st Logic - ...	Input 2byte			2 bytes	C	-	W	-	U	pulses	Low
18	1st Logic - ...	Output 1byte-low			1 byte	C	-	-	T	-	counter pulses (0..255)	Low
19	1st Logic - ...	Output 1byte-high			1 byte	C	-	-	T	-	counter pulses (0..255)	Low

“1x2byte -> 2x1byte”function: converts one 2byte values to two 1byte value, such as Input 2byte = 55500 (\$D8 CC) -> Output 1byte-low = 204 (\$CC), Output 1byte-high =216 (\$D8)

Number	Name	Object Function	Description	Group Address	Length	C	R	W	T	U	Data Type	Priority
11	1st Logic - ...	Input 4byte			4 bytes	C	-	W	-	U	counter pulses (unsigned)	Low
18	1st Logic - ...	Output 2byte-low			2 bytes	C	-	-	T	-	pulses	Low
19	1st Logic - ...	Output 2byte-high			2 bytes	C	-	-	T	-	pulses	Low

“1x4byte -> 2x2byte”function: converts one 4byte values to two 2byte value, such as Input 4byte = 78009500 (\$04 A6 54 9C) -> Output 2byte-low = 21660 (\$54 9C), Output 2byte-high =1190 (\$04 A6)

Number	Name	Object Function	Description	Group Address	Length	C	R	W	T	U	Data Type	Priority
11	1st Logic - ...	Input 3byte			3 bytes	C	-	W	-	U	RGB value 3x(0..255)	Low
17	1st Logic - ...	Output 1byte-low			1 byte	C	-	-	T	-	counter pulses (0..255)	Low
18	1st Logic - ...	Output 1byte-middle			1 byte	C	-	-	T	-	counter pulses (0..255)	Low
19	1st Logic - ...	Output 1byte-high			1 byte	C	-	-	T	-	counter pulses (0..255)	Low

“1x3byte -> 3x1byte”function: converts one 3byte values to three 1byte value, such as Input 3byte = \$78 64 C8-> Output 1byte-low = 200 (\$C8) , Output 1byte-middle = 100 (\$64) , Output 1byte-high =120 (\$78)

Number	Name	Object Function	Description	Group Address	Length	C	R	W	T	U	Data Type	Priority
11	1st Logic - ...	Input 1byte-low			1 byte	C	-	W	-	U	counter pulses (0..255)	Low
12	1st Logic - ...	Input 1byte-middle			1 byte	C	-	W	-	U	counter pulses (0..255)	Low
13	1st Logic - ...	Input 1byte-high			1 byte	C	-	W	-	U	counter pulses (0..255)	Low
19	1st Logic - ...	Output 3byte			3 bytes	C	-	-	T	-	RGB value 3x(0..255)	Low

“3x1byte -> 1x3byte”function: converts three 1byte values to a 3byte value, such as Input 1byte-low = 150 (\$96), Input 1byte-middle = 100 (\$64), Input 1byte-high = 50 (\$32)-> Output 3byte = \$32 64 96

Fig.6.6.4 “Format convert” Communication object

NO.	Object Function	Name	Data Type	Flag	DPT	
11	Input ...	1st Logic - {...}	1bit	C,W,U	1.001 switch	
			1byte			5.010 counter pulses(0..255)
			2byte			7.001 pulses
			3byte			232.600 RGB value 3x(0..255)
			4byte			12.001 counter pulses
The communication object is used to input a value that needs to be converted.						
19	Output ...	1st Logic - {...}	1bit	C,T	1.001 switch	
			2bit			2.001 switch control
			1byte			5.010 counter pulses(0..255)

			2byte		7.001 pulses
			3byte		232.600 RGB value 3x(0..255)
			4byte		12.001 counter pulses
The communication object is used to output the converted value.					

Table.6.6.4 "Format convert" Communication object

6.6.5. "Gate function" Communication object

Number	Name	Object Function	Description	Group Address	Length	C	R	W	T	U	Data Type	Priority
11	1st Logic - ...	Input			1 bit	C	-	W	-	-	switch	Low
12	1st Logic - ...	Gate input			1 bit	C	-	W	-	-	boolean	Low
19	1st Logic - ...	Output			1 bit	C	-	-	T	-	switch	Low

Fig.6.6.5 "Gate function" Communication object

NO.	Object Function	Name	Data Type	Flag	DPT
11	Input	1st Logic - {{...}}	1bit	C,W	1.001 switch
			1byte		5.001 percentage
			2byte		5.010 counter pulses
					9.001 temperature
					7.001 pulses
The communication object is used to input a value that needs to gate filter.					
12	Gate input	1st Logic - {{...}}	1bit	C,W	1.002 boolean
The communication object is used to control the switch status of gate input. Input signal is allowed to pass when gate open, then output, and the current input status is still sent if there is a change; Can not pass when gate close.					
13	Output	1st Logic - {{...}}	bit	C,T	1.001 switch
			1byte		5.001 percentage
			2byte		5.010 counter pulses
					9.001 temperature
					7.001 pulses
The communication object is used to output the value after gate filtering. Only when gate input status is open, output is available, defined by the object "Gate input".					

Table.6.6.5 "Gate function" Communication object

6.6.6. "Delay function" Communication object

Number	Name	Object Function	Description	Group Address	Length	C	R	W	T	U	Data Type	Priority
11	1st Logic - ...	Input			1 bit	C	-	W	-	-	switch	Low
19	1st Logic - ...	Output			1 bit	C	-	-	T	-	switch	Low

Input/Output - 1bit[On/Off]

Number	Name	Object Function	Description	Group Address	Length	C	R	W	T	U	Data Type	Priority
11	1st Logic - ...	Input			1 byte	C	-	W	-	-	percentage (0..100%)	Low
19	1st Logic - ...	Output			1 byte	C	-	-	T	-	percentage (0..100%)	Low

Input/Output - 1byte[0..100%]

Number	Name	Object Function	Description	Group Address	Length	C	R	W	T	U	Data Type	Priority
11	1st Logic - ...	Input			1 byte	C	-	W	-	-	counter pulses (0..255)	Low
19	1st Logic - ...	Output			1 byte	C	-	-	T	-	counter pulses (0..255)	Low

Input/Output - 1byte[0..255]

Number	Name	Object Function	Description	Group Address	Length	C	R	W	T	U	Data Type	Priority
11	1st Logic - ...	Input			2 bytes	C	-	W	-	-	temperature (°C)	Low
19	1st Logic - ...	Output			2 bytes	C	-	-	T	-	temperature (°C)	Low

Input/Output - 2byte[Float]

Number	Name	Object Function	Description	Group Address	Length	C	R	W	T	U	Data Type	Priority
11	1st Logic - ...	Input			2 bytes	C	-	W	-	-	pulses	Low
19	1st Logic - ...	Output			2 bytes	C	-	-	T	-	pulses	Low

Input/Output - 2byte[0..65535]

Fig.6.6.6 "Delay function" Communication object

NO.	Object Function	Name	Data Type	Flag	DPT
11	Input	1st Logic - {{...}}	1bit	C,W	1.001 switch
			1byte		5.001 percentage
			2byte		5.010 counter pulses
					9.001 temperature
The communication object is used to input a value that needs to delay.					
19	Output	1st Logic - {{...}}	1bit	C,T	1.001 switch
			1byte		5.001 percentage
			2byte		5.010 counter pulses
					9.001 temperature
The communication object is used to output that needs to delay converted value, delay time is defined by the parameter.					
					7.001 pulses

Table.6.6.6 "Delay function" Communication object

6.6.7. "Staircase lighting" Communication object

Number	Name	Object Function	Description	Group Address	Length	C	R	W	T	U	Data Type	Priority
11	1st Logic - ...	Trigger value			1 bit	C	-	W	-	-	trigger	Low
12	1st Logic - ...	Light-on duration time			2 bytes	C	-	W	-	-	time (s)	Low
19	1st Logic - ...	Output			1 bit	C	-	-	T	-	switch	Low

Fig.6.6.7 "Staircase lighting" Communication object

NO.	Object Function	Name	Data Type	Flag	DPT
11	Trigger value	1st Logic - {{...}}	1bit	C,W	1.017 trigger
The communication object is used to receive the value to trigger staircase lighting.					
12	Light-on duration time	1st Logic - {{...}}	2byte	C,W	7.005 time(s)
The communication object is used to modify the staircase light-on duration time, the modified range is referenced from the range defined by the parameter, take the limit value if exceeded.					
19	Output	1st Logic - {{...}}	1bit 1byte	C,T	1.001 switch 5.010 counter pulses
The communication object is used to output value 1 when trigger, and send value 2 after duration time. Telegram value is determined by the parameter setting datatype.					

Table.6.6.7 "Staircase lighting" Communication object

6.7. "Scene group function" Communication object

Number	Name	Object Function	Descr	Group	Length	C	R	W	T	U	Data Type	Priority
83	Scene Group	Main scene trigger			1 byte	C	-	W	-	-	scene number	Low
84	1st Scene Group - Output 1 - ...	1bit value			1 bit	C	-	-	T	-	switch	Low

1 bit value

Number	Name	Object Function	Descr	Group	Length	C	R	W	T	U	Data Type	Priority
83	Scene Group	Main scene trigger			1 byte	C	-	W	-	-	scene number	Low
84	1st Scene Group - Output 1 - ...	1byte unsigned value			1 byte	C	-	-	T	-	counter pulses (0..255)	Low

1 byte

Number	Name	Object Function	Descr	Group	Length	C	R	W	T	U	Data Type	Priority
83	Scene Group	Main scene trigger			1 byte	C	-	W	-	-	scene number	Low
84	1st Scene Group - Output 1 - ...	HVAC mode			1 byte	C	-	-	T	-	HVAC mode	Low

HVAC mode

Number	Name	Object Function	Descr	Group	Length	C	R	W	T	U	Data Type	Priority
83	Scene Group	Main scene trigger			1 byte	C	-	W	-	-	scene number	Low
84	1st Scene Group - Output 1 - ...	2byte unsigned value			2 bytes	C	-	-	T	-	pulses	Low

2byte unsigned value

Number	Name	Object Function	Descr	Group	Length	C	R	W	T	U	Data Type	Priority
83	Scene Group	Main scene trigger			1 byte	C	-	W	-	-	scene number	Low
84	1st Scene Group - Output 1 - ...	Temperature			2 bytes	C	-	-	T	-	temperature (°C)	Low

Temperature

Number	Name	Object Function	Descr	Group	Length	C	R	W	T	U	Data Type	Priority
83	Scene Group	Main scene trigger			1 byte	C	-	W	-	-	scene number	Low
84	1st Scene Group - Output 1 - ...	RGB value			3 bytes	C	-	-	T	-	RGB value 3x(0..255)	Low

RGB value

Number	Name	Object Function	Descr	Group	Length	C	R	W	T	U	Data Type	Priority
83	Scene Group	Main scene trigger			1 byte	C	-	W	-	-	scene number	Low
84	1st Scene Group - Output 1 - ...	RGBW value			6 bytes	C	-	-	T	-	RGBW value 4x(0..100%)	Low



















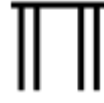

RGBW value









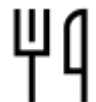













Fig.6.7 "Scene Group setting" Communication object























NO.	Object Function	Name	Data Type	Flag	DPT
83	Main scene trigger	Scene Group	1byte	C,W	17.001 scene number
<p>This communication object triggers each output in the scene group to send a specific value to the bus by recalling the scene number. Telegrams: 0.. 63</p>					
84	1bit value 1byte unsigned value HVAC mode 2byte unsigned value Temperature RGB value RGBW value	1st Scene Group-Output 1 - {...}	1bit 1byte 2byte 3byte 6byte	C,T	1.001 switch 5.010 counter pulses 20.102 HVAC mode 7.001 pulses 9.001 temperature 232.600 RGB value 3x(0..255) 251.600 DPT_Colour_RGBW
<p>When a scene is recalled, the communication object is used to send the corresponding output value of the scene to the bus. If the output is not set to this scene, it will not be sent.</p> <p>A total of 8 scene groups can be set up, with 8 outputs per group.</p> <p>The name in parentheses changes with the parameter "Description for Output 1 function". If description is empty, display "1st Scene Group-Output 1 - ..." by default.</p>					



















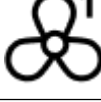



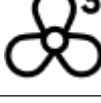

Table 6.7 "Scene Group setting" Communication object

























Chapter 7 Icon list























ETS options	Icon	ETS options	Icon
Light on		General scene 1	
Light off		General scene 2	
Ceiling light		General scene 3	
Downlight		Curtain	
Wall light		Blind(open/close)	
Spotlight		Blind(up/down)	
Chandelier		Blind(with slat)	
Floor light		Shutter up	
RGB lamp		Shutter down	
Colour temperature		Blind open 1	
LED strip		Blind close 1	















Blind open 2		Go home 2	
Blind close 2		Leave home 2	
Arrow up		Welcome	
Arrow down		Meeting(guest)	
Arrow left		Dinner	
Arrow right		Party	
Plus		Sleeping	
Minus		Reading	
Brighter		Media	
Darker		Cleaning	
Go home 1		Comfort	
Leave home 1		Standby	

Economy		Fan	
Protection		Gate close	
Wake up		Gate open	
TV		Sliding door close	
Washing machine		Sliding door open	
Dryer		Garage door close	
Electric pump		Garage door open	
Rubbish		Door lock	
Socket(CN)		Power supply	
Socket(EU)		Window 1 close	
Socket(CN)		Window 1 open	

Window 2 close		Auto mode	
Window 2 open		Heating mode	
Window 3 close		Cooling mode	
Window 3 open		Dehumidification mode	
Alarm 1		Refresh mode	
Alarm 2		Sleep mode	
Heating/Cooling system		Wind direction	
Air conditioner		Fan speed	
Floor heating		Fan speed off	
Water heating		Fan speed 1	
Heating system		Fan speed 2	
Ventilation system		Fan speed 3	
Mode		Fan speed 4	

Fan speed 5		Playlist	
Fan speed auto		Presence	
Music		Sensor	
Play		Water sensor	
Pause		Smoke sensor	
Volume +		Fire sensor	
Volume -		External alarm	
Previous track		Internal alarm	
Next track		Sensor activated	
Random playback		Sensor disabled	
Sequential playback		On	
Repeat playlist		Off	

Open		Mute	
Close		Day	
Power on/off		Night	
Check mark		Text	
Unlock		Message	
Lock		Setting	
Stop charge		Room temperature	
Charge		Timmer	
Partial battery		PM2.5	
Battery depleted		PM10	
Unmute		TVOC/VOC	

CO2		Power meter	
Temperature		Energy	
Humidity		Home energy	
Brightness		Electricity	
Windspeed		Photovoltaics	
Rain		Power company	
Current		Energy storage	
Voltage	