

User manual

K-BUS S series

KNX Multifunctional Thermostat, 6 Buttons_V1.3

CHMTB-06/S.x.1y

(x=1: Normal glass; x=2: Mirror glass)

(y=0: White; y=1: Black; y=3:Gray; y=4:Golden)

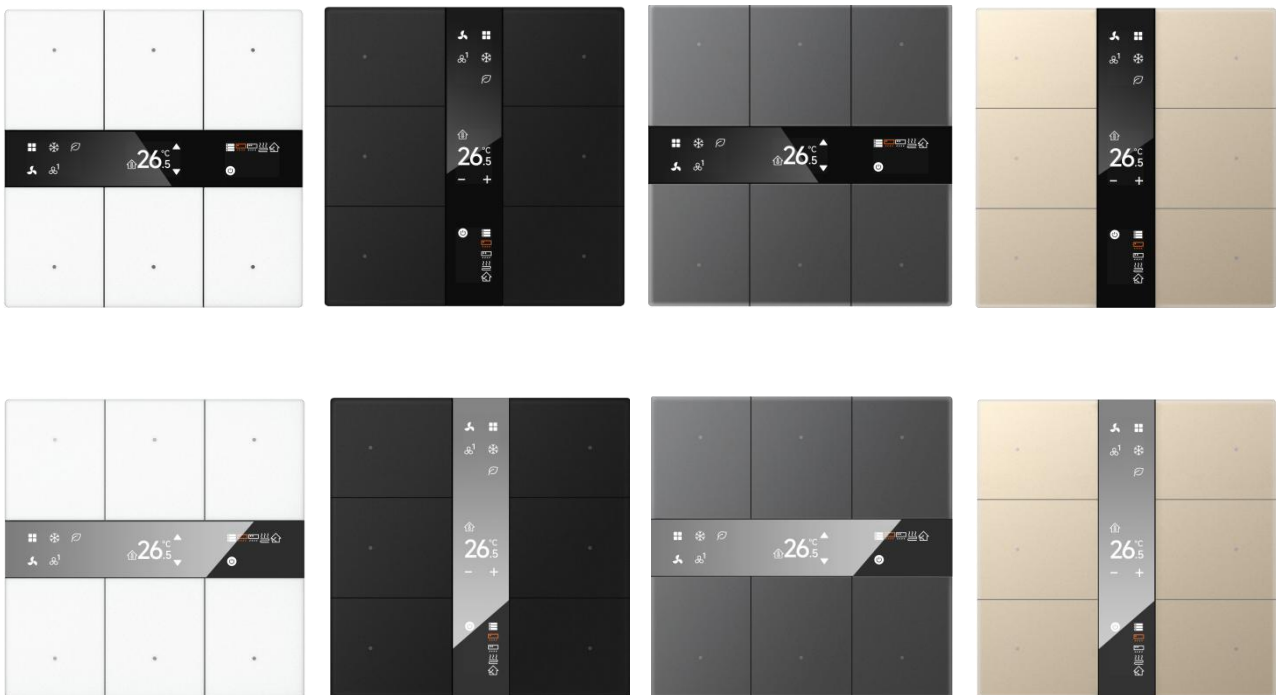

KNX/EIB Home and Building Control System

Attentions

1. Please keep devices away from strong magnetic field, high temperature, wet environment;

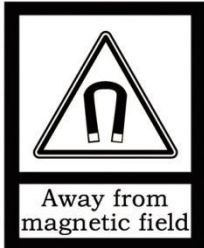

2. Do not fall the device to the ground or make them get hard impact;



3. Do not use wet cloth or volatile reagent to wipe the device;



4. Do not disassemble the devices.

Contents

Chapter 1 Summary	1
Chapter 2 Technical Data	3
Chapter 3 Dimension and Structural Diagram	4
3.1. Dimension Diagram	4
3.2. Structural Diagram	5
Chapter 4 Project Design and Programming	7
Chapter 5 Parameter setting description in the ETS	9
5.1. KNX Secure	9
5.2. Parameter window "General"	13
5.2.1. Parameter window "General setting"	13
5.2.2. Parameter window "Brightness setting"	18
5.2.3. Parameter window "Screen saver setting"	21
5.2.4. Parameter window "Night mode setting"	24
5.2.5. Parameter window "RGB light setting"	25
5.2.6. Parameter window "Proximity setting"	29
5.2.7. Parameter window "Advanced setting"	31
5.3. Parameter window "Internal temperature measurement"	32
5.4. Parameter window "Function setting"	35
5.4.1. Parameter window "FCU setting"	42
5.4.1.1. Parameter window "Setpoint"	52
5.4.1.2. Parameter window "Heating/Cooling control"	58
5.4.1.3. Parameter window "Fan"	65
5.4.1.4. Parameter window "Scene "	72
5.4.2. Parameter window "VRF setting"	74
5.4.2.1. Parameter window "Mode"	77
5.4.2.2. Parameter window "Fan"	78
5.4.2.3. Parameter window "Scene "	80
5.4.3. Parameter window "Floor heating setting"	82
5.4.3.1. Parameter window "Scene "	90
5.4.4. Parameter window "Ventilation setting"	92
5.4.4.1. Parameter window "Fan auto.control"	96
5.4.4.2. Parameter window "Mode"	101
5.4.4.3. Parameter window "Scene "	102

5.4.5. Parameter window“Audio”	104
5.4.6. Parameter window“Customized colour”	109
5.5. Parameter window“Logic function”	110
5.5.1. “AND/OR/XOR”	111
5.5.2. “Gate forwarding”	114
5.5.3. “Threshold comparator”	116
5.5.4. “Format convert”	119
5.5.5. “Gate function”	120
5.5.6. “Delay function”	122
5.5.7. “Staircase lighting”	123
5.6. Parameter window“Scene Group”	125
Chapter 6 Description of Communication Object	128
6.1. “General”Communication Object	128
6.2. “Internal sensor”Communication Object	132
6.3. “Function setting”Communication Object	133
6.3.1. “FCU”Communication Object	133
6.3.2. “VRF”Communication Object	141
6.3.3. “Floor heating”Communication Object	144
6.3.4. “Ventilation”Communication Object	147
6.3.5. “Audio ”Communication Object	151
6.4. “Logic”Communication Object	156
6.4.1. “AND/OR/XOR”Communication Object	156
6.4.2. “Gate forwarding”Communication Object	157
6.4.3. “Threshold comparator”Communication Object	158
6.4.4. “Format convert”Communication Object	160
6.4.5. “Gate function”Communication Object	163
6.4.6. “Delay function”Communication Object	165
6.4.7. “Staircase lighting”Communication Object	166
6.5. “Scene Group”Communication Object	167
Chapter 7 Icon list	168

Chapter 1 Summary

S series KNX Multifunctional Thermostat, 6 Buttons is mainly applied in building control system, connected to the bus via KNX connection terminals and installed together with other devices on the bus to become a system. It's functionally simple and intuitive to operate. Users can plan according to their own needs to performs these functions in the system.

S series KNX Multifunctional Thermostat, 6 Buttons not only can serve as a multifunctional thermostat for FCU control, VRF control, Floor heating, Ventilation system, temperature detection, etc. It can also serve as a audio control, used to control background music playing, such as: power on/off, play/pause, previous/next track, volume increase/decrease, mute, play modes, track/artist/album name display, etc. You can adjust the function configuration according to your requirements, and the screen displays the current control status.

Additionally, it not only supports various sensors such as proximity and temperature sensor, meets the requirements of most applications. It also supports screen saver, panel locking function, night mode, screen brightness setting, RGB light setting, logic function, scene group function to make your life smarter.

S series KNX Multifunctional Thermostat, 6 Buttons is powered from KNX bus. It is available to assign the physical address and configure the parameters by engineering design tools ETS with .knxprod (support edition ETS5.7 or higher).

The functions are summarized as followed:

- 0.85 inch colour LCD, display area resolution 128x80
- Support vertical or horizontal display via ETS
- Screen saver and panel locking function
- Screen brightness adjustment and RGB LED indication function
- Day/Night signal
- Built-in temperature sensor, proximity sensor
- 8 Logic functions, with AND, OR, XOR, Gate forwarding, Threshold comparator, Format convert, Gate function, Delay function and Staircase lighting
- 8 Scene group functions, and 8 outputs for per Scene Group

- Multifunction thermostat: Room temperature control function(Select FCU control or VRF control), Floor heating and Ventilation function. Each with 5 scenes, all can be set to function lock.
- Audio control: used to control background music playing, such as: power on/off, play/pause, previous track/next track, volume increase/decrease, mute, play mode,track/artist/album name display, etc.
- Support the KNX Data Secure

Chapter 2 Technical Data

Power Supply	Bus voltage	21-30V DC, via the KNX bus
	Bus current	<26mA/24V; <20mA/30V
	Bus consumption	<0.63W
Connection	KNX	Bus connection terminal(Red/Black)
Operation and display	Programming button and red LED	For assigning the physical address
Temperature	Operation	- 5 °C ... 45 °C
	Storage	- 25 °C ... 55 °C
	Transport	- 25 °C ... 70 °C
Environment	Humidity	<93%, except dewing
Dimension	86 × 86 × 35.6mm	
Weight	0.17kg	
Mounting	European 80 type wall-mounted box or 86 type wall-mounted box	

Chapter 3 Dimension and Structural Diagram

3.1. Dimension Diagram

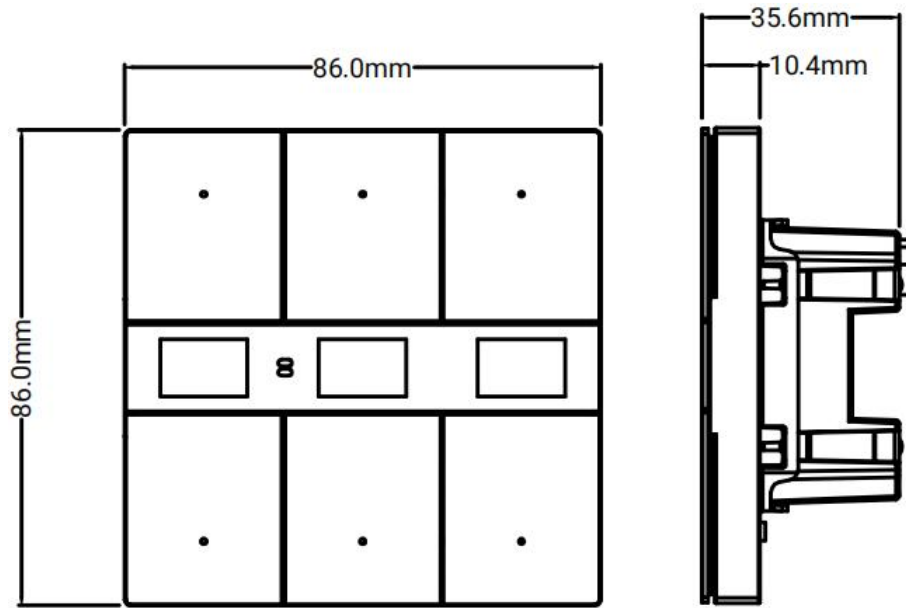

Panel dimension

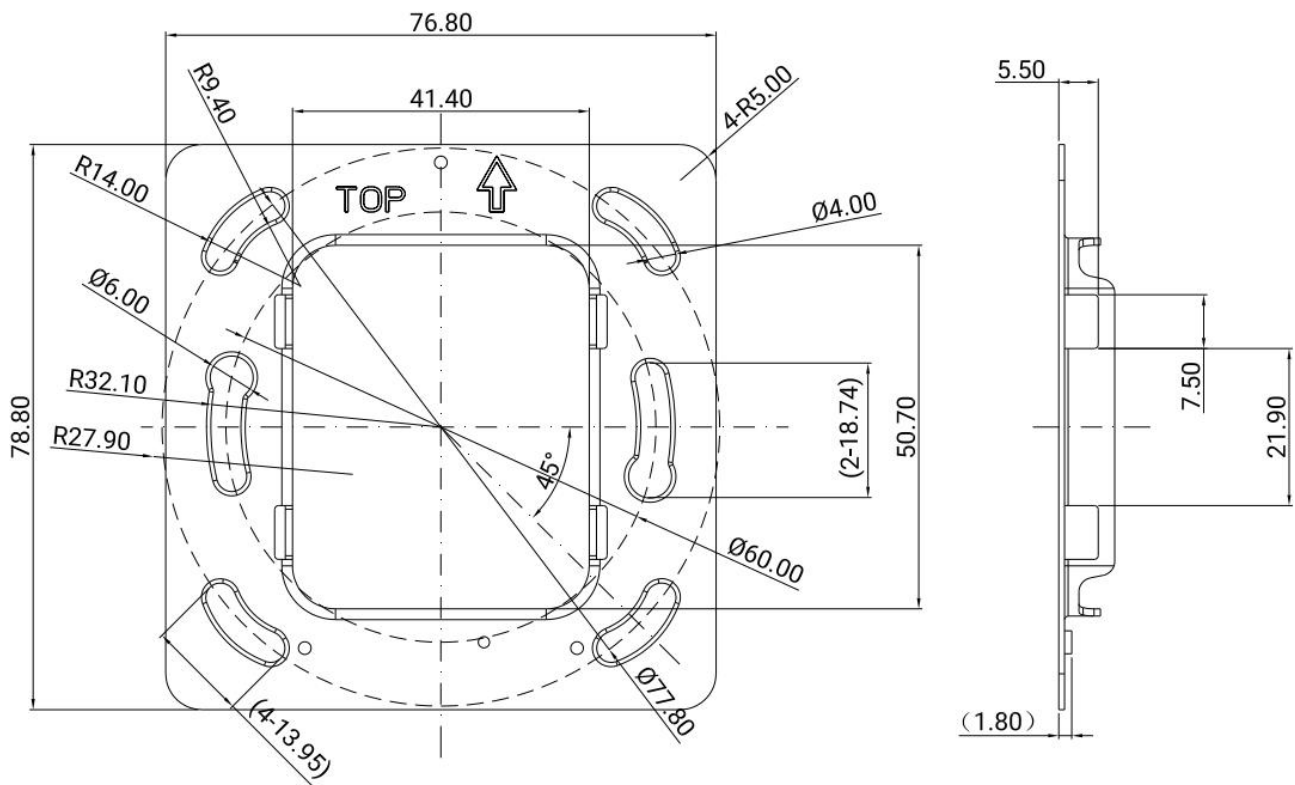

Metal plate dimension

3.2. Structural Diagram

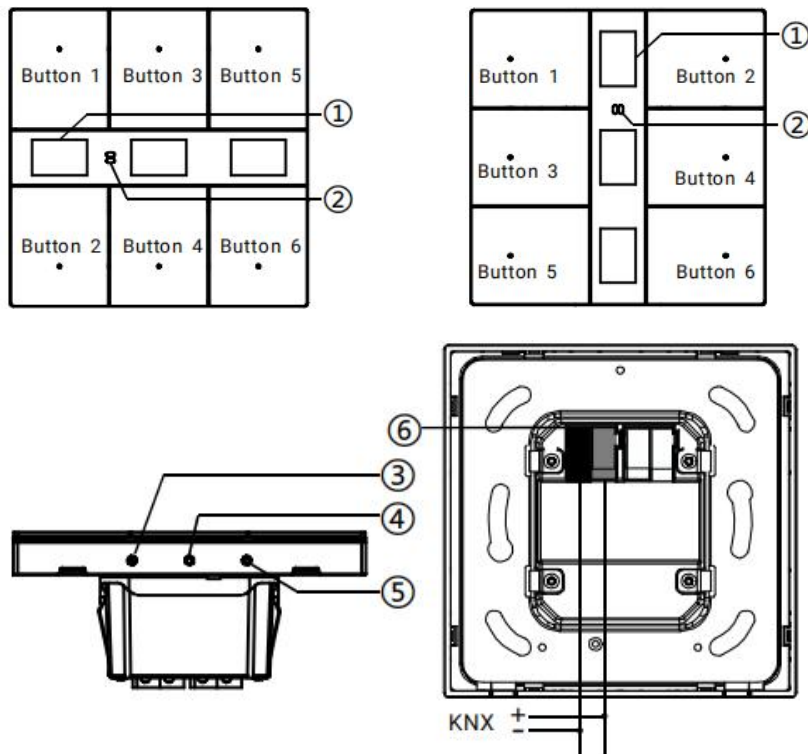

① Display area

④ Programming button

② Proximity sensor

⑤ Internal temperature sensor

③ Programming LED

⑥ KNX bus connection terminal

Reset the device to the factory configuration: press the programming button and hold for 4 seconds then release, repeat the operation for 4 times, and the interval between each operation is less than 3 seconds

Note: In horizontal display mode, the screw holes of the wall-mounted box are fixed in the left and right, as shown in Fig.1; while in vertical display mode, rotate the product clockwise by 90° during installation, and the screw holes of the wall-mounted box must be fixed in the up and bottom, as shown in Fig.2.

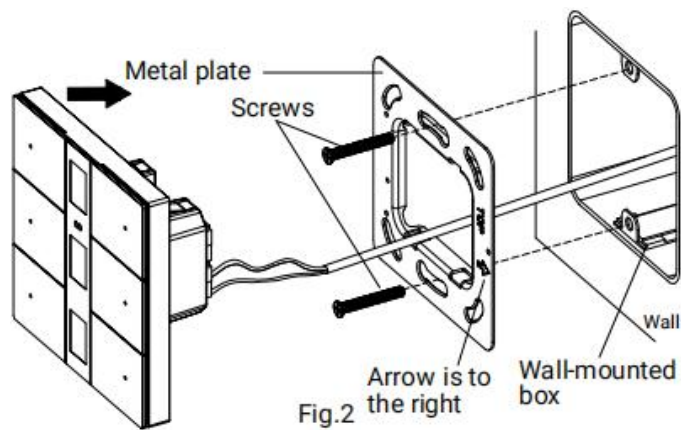
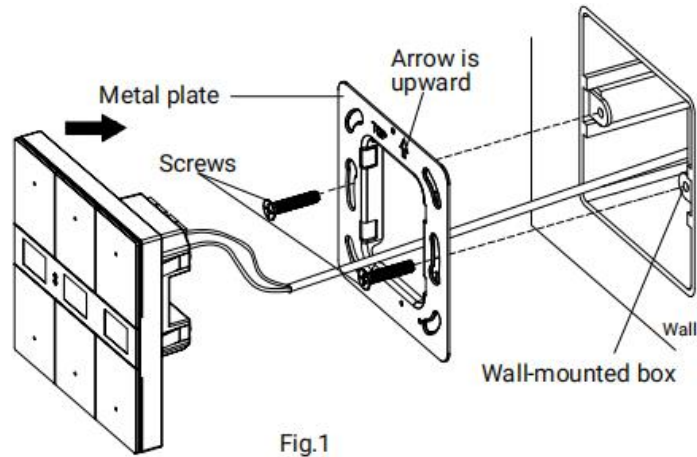

Chapter 4 Project Design and Programming

Application	Maximum of communication objects	Maximum number of group addresses	Maximum number of associations	Secure group addresses
FCU/VRF/Floor Heating/Ventilation/0 OC0 1.1	330	587	587	300

General function

General function includes device in operation setting, KNX telegrams delay time setting, request device status after voltage recovery, and supports to lock the whole device.

Support to set the extension functions, including screen brightness, screen saver, normal/night mode, RGB light and proximity setting.

Internal temperature measurement

Support internal temperature measurement, and can be sent to the bus after change or cyclically.

Support high or low temperature alarm, and can be sent to the bus.

Multifunction thermostat

FCU control: support to functions, including control mode input, heating/cooling system, operation mode and setpoint temperature, fan speed, window contact, presence detector, temperature threshold, 2 points and PI control algorithm and etc.

Note: The screen temperature display range is -9.9 to 99.9°C.

VRF control: only applicable to VRF Air Conditioner System, work with KNX to VRF air conditioner gateway for control, support power on/off, setpoint temperature, mode, fan speed, vanes swing and other control functions.

Note: The screen temperature display range is -9.9 to 99.9°C.

Floor heating: support to 2 points and PI control algorithm, and automatically switch the floor heating according to the temperature difference. In addition, you can set the scene function of floor heating, and the adjustable range setting of setpoint temperature value.

Note: The screen temperature display range is -9.9 to 99.9°C.

Ventilation function: support auto control, it is linkage control with PM2.5/CO2/VOC and support the output types of 1bit and 1byte. Also support three/five level fan speed and custom mode control.

Note: The text displayed on the screen, such as CO2 in fan auto. control or mode function descriptions will not change font size based on the parameter "UI size" setting.

Each of the above functions comes with 5 scenes, all of which can be set for function locking.

Audio control

It is used to control background music playing, for example, power on/off, play/pause, previous track/next track, volume increase/decrease, mute, play modes, track/artist/album name display etc.

Logic function

Up to support 8 channels of logic, each channel up to support 8 inputs and 1 logic result.

Logic function support functions, including AND, OR, XOR, Gate forwarding, Threshold comparator, Format convert, Gate function, Delay function and Staircase lighting.

Scene group function

Up to support 8 channels of scene group forward, each group up to support 8 configurable output, datatype is optional 1bit/1byte/2byte.

Chapter 5 Parameter setting description in the ETS

5.1. KNX Secure

S series KNX Multifunctional Thermostat, 6 Buttons is a KNX device that complies with the KNX secure standard. That is, you can run the device in safe way.



Fig.5.1 (1) "KNX Secure" parameter window

The device with KNX secure will be displayed notes on ETS, as shown as Fig.5.1(1).

If secure commissioning is activated in ETS project, the following information must be considered during device debugging:



❖ It is essential to assign a project password as soon as a KNX Secure device is imported into a project. This will protect the project against unauthorized access.

The password must be kept in a safe place – access to the project is not possible without it (not even the KNX Association or device manufacturer will be able to access it)!

Without the project password, the commissioning key will not be able to be imported.

❖ A commissioning key is required when commissioning a KNX Secure device (first download). This key (FDSK = Factory Default Setup Key) is included on a sticker on the side of the device, and it must be imported into the ETS prior to the first download:

✧ On the first download of the device, a window pops up in the ETS to prompt the user to enter the key, as shown in Fig.5.1 (2) below.

The certificate can also be read from the device using a QR scanner (recommended).

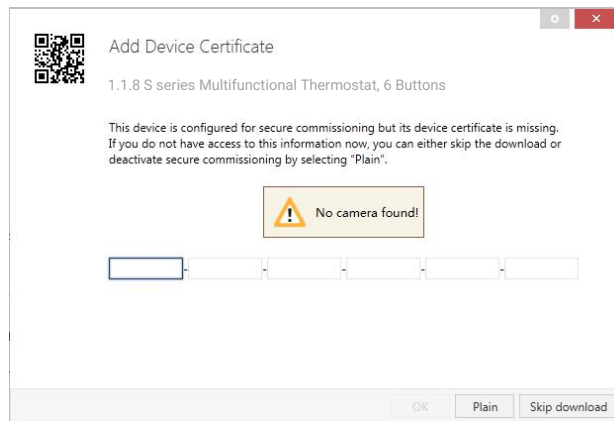

Fig.5.1(2) Add Device Certificate window

✧ Alternatively, the certificates of all Secure devices can be entered in the ETS beforehand.

This is done on the "Security" tab on the project overview page, as shown in Fig.5.1(3) below.

The certificates can be also added to the selected device in the project, as shown in Fig.5.1(4).

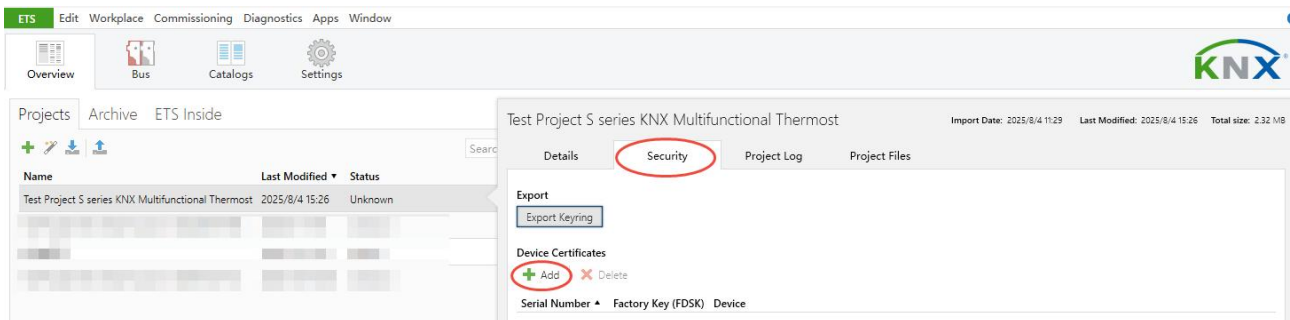

Fig.5.1(3) Add Device Certificate

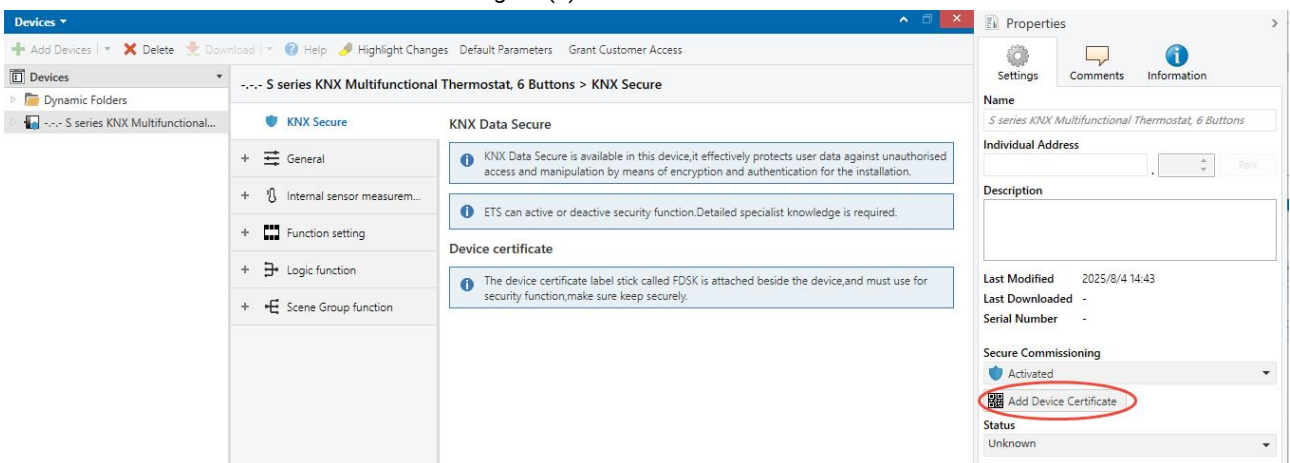

Fig.5.1(4) Add Device Certificate

✧ There is a FDSK sticker on the device, which is used for viewing FDSK number.

Without the FDSK, it will no longer be possible to operate the device in KNX Secure mode after a reset.

The FDSK is required only for initial commissioning. After entering the initial FDSK, the ETS will assign a new key, as shown in Fig.5.1(5) below.

The FDSK will be required again only if the device was reset to its factory settings (e.g. If the device is to be used in a different ETS project).

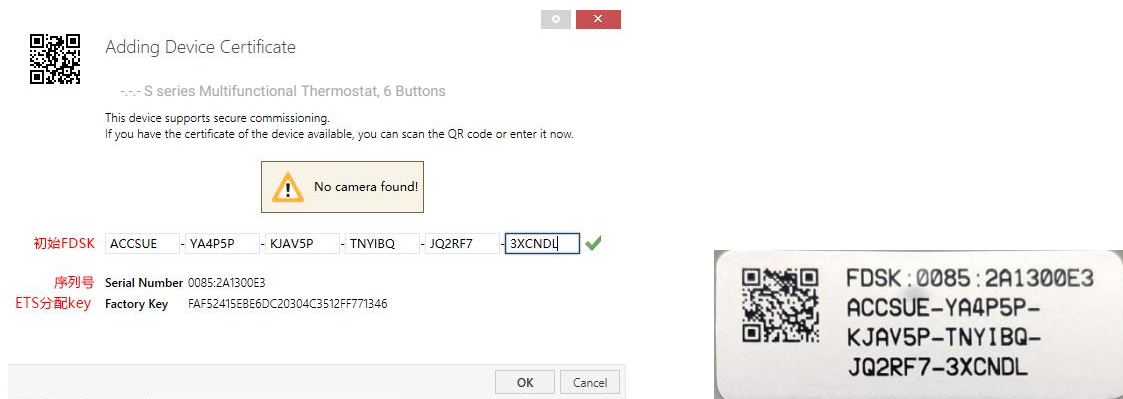

Fig.5.1(5)

Example:

If this application in the project needs to be tried with another device, it is no longer the original device. When the application is downloaded to a new device, the following prompt will appear on the left of Fig.5.1(6), click yes, the Add Device Certificate window will appear, then enter the initial FDSK of the new device, and you need to reset the device to the factory settings (it is not required if the device is still factory default; If it has been used, it will be required to reset, otherwise the following error message will appear on the right of Fig.5.1(6)), and then the device can be successfully downloaded again.

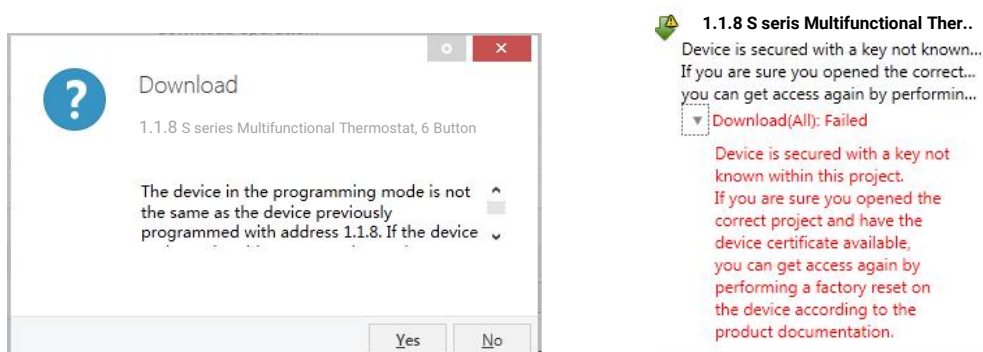

Fig.5.1(6) Example

Whether the device is replaced in the same project, or the device is replaced in a different project, the processing is similar: **Reset the device to the factory settings, then reassign the FDSK.**

After the device is downloaded successfully, the label Add Device Certificate turns gray, indicating that the key for this device has been assigned successfully, as shown in Fig.5.1(7) below.

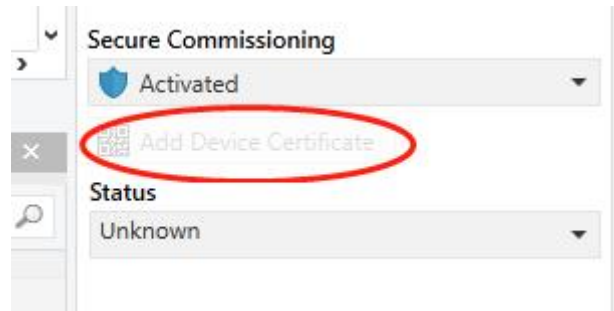

Fig.5.1(7)

ETS generates and manages keys:

Keys and passwords can be exported as needed to the use of security keys outside of the associated ETS projects. As shown in Fig.5.1(8) below, the file extension is .knxkeys.

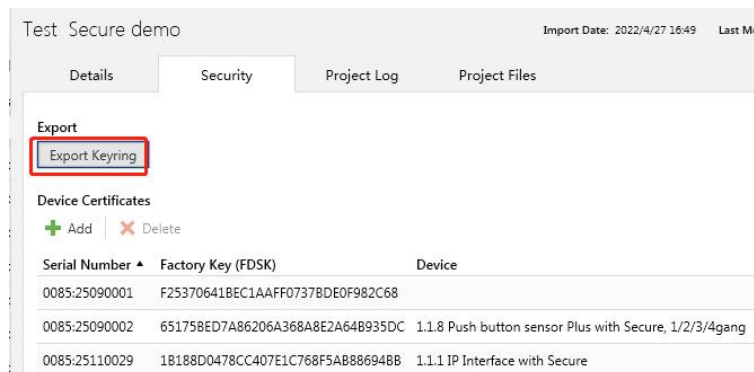

Fig.5.1(8)

Note: Any USB interface used for programming a KNX Secure device must support "long frames".

Otherwise ETS will report a download failure information, as shown below.

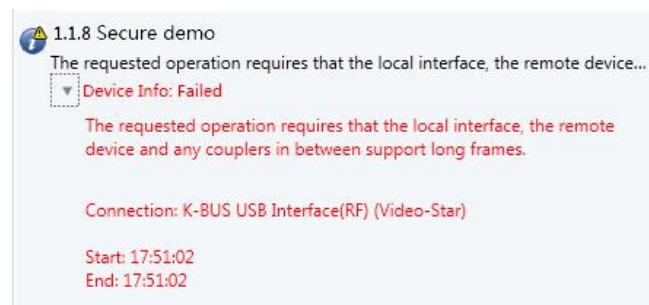

Fig.5.1(9)

5.2. Parameter window“General”

5.2.1. Parameter window“General setting”

Send delay after voltage recovery [0..15]	<input type="text" value="0"/>	s
Send cycle of In operation telegram [1..240,0=inactive]	<input type="text" value="0"/>	s
Long operation for button after [5..250]	<input type="text" value="5"/>	*0.1s

Screen display setting

i Note:The codepage option in the property of project must select the Unicode(UTF-8)

The encode data of telegram for 14byte object from bus UTF-8 ISO8859-1

Display mode Vertical Horizontal

UI size Large Normal

Theme Pure white Colours

Temperature display units Celsius(°C) Fahrenheit(°F)

Extension function

Screen saver

Night mode

Proximity function

Panel locking function

Allow to wake up for button operation or proximity trigger when the screen is off and locked

Send extension scene command when locking at day

Scene NO.

Send extension scene command when locking at night

Scene NO.

Fig.5.2.1 “General setting” Parameter window

Parameter“Send delay after voltage recovery [0..15]”

This parameter is for setting the delay time that sends status request telegram to bus after the device voltage recovery. Options: **0..15 s**

The setting dose not contain the device initialization time, and bus telegrams received during delay time will be recorded.

Parameter "Send cycle of In operation telegram [1..240,0=inactive]"

This parameter is for setting the time interval when this device cycle send telegrams through the bus to indicate this device in normal operation. When set to "0", the object "In operation" will not send a telegram. If the setting is not "0", the object "In operation" will send a telegram according to the set period time with logic "1" to the bus. Options: **0...240s, 0= inactive**

As to reduce the bus load as much as possible, the maximum time interval should be selected according to actual needs.

Parameter "Long operation for button after [5...250]"

This parameter is for setting the trigger time of the long operation for button. Options: **5..250 *0.1s**

Screen display setting

Note: The codepage option in the property of project must select the Unicode(UTF-8)

UTF-8 setting as shown as follow:

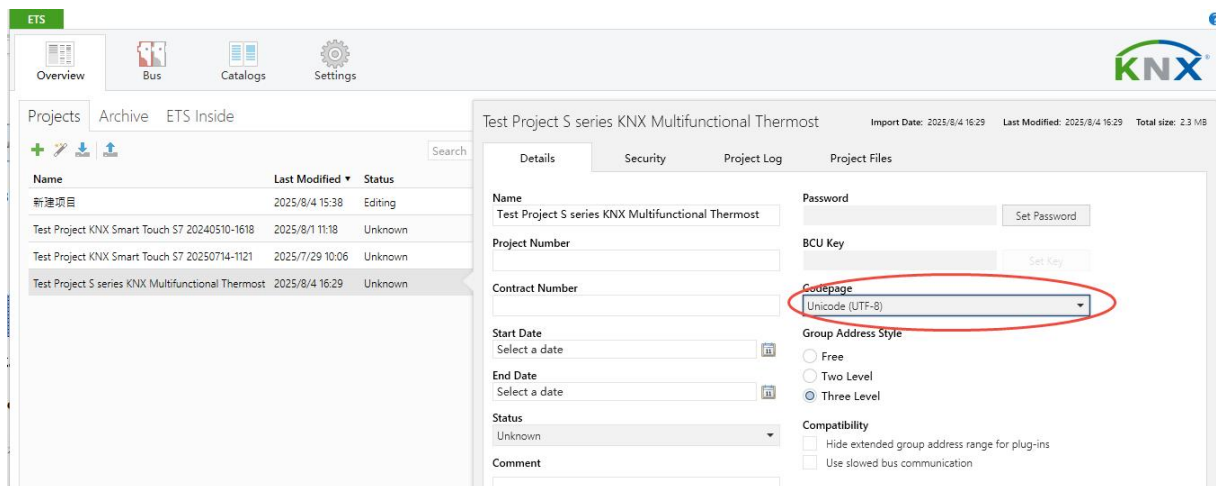

Parameter "The encode data of telegram for 14byte object from bus"

This parameter is for setting the encode data of telegram for 14byte object from bus. Options:

UTF-8

ISO8859-1

Parameter "Display mode"

This parameter is for setting display mode, according to the installation direction of the device.

Options:

Vertical

Horizontal

Parameter "UI size"

This parameter is for setting the size of the icons displayed on the screen. Options:

Large

Normal

Parameter "Theme"

This parameter is for setting the theme displayed on the screen. Options:

Pure white

Colours

Parameter "Temperature display units"

This parameter is for setting the temperature unit displayed on the screen. Options:

Celsius(°C)

Fahrenheit(°F)

Extension function

Parameter "Screen saver"

When this parameter is enabled, the "screen saver setting" is visible. This function is described in detail in [chapter 5.2.3](#).

Parameter "Night mode"

When this parameter is enabled, the "night mode setting" is visible. This function is described in detail in [chapter 5.2.4](#).

Parameter "Proximity function"

When this parameter is enabled, the "proximity setting" is visible. This function is described in detail in [chapter 5.2.6](#).

Parameter "Panel locking function"

This parameter is for setting whether to enable panel locking function. Options:

Disable

Unlock=1/Lock=0

Unlock=0/Lock=1

After receiving the telegram of panel lock, the screen switches to the lock interface, as shown in



the right figure:

After receiving the unlock signal, it automatically returns to the normal function interface, or enters the screen saver interface after a delay.

Parameters as follow are visible when "Disable" is not selected.

—Parameter "Allow to wake up for button operation or proximity trigger when the screen is off and locked"

This parameter is for setting whether allow to wake up for button operation or proximity trigger when the screen is off and locked.

—Parameter "Send extension scene command when locking"

—Parameter "Send extension scene command when locking at day"

—Parameter "Send extension scene command when locking at night"

These parameter are for setting whether to enable send extension scene command when locking, you can set the scene number and scene object when enabled. If night mode is enabled, the scene numbers at day/night can be configured independently.

When the panel is locking, operate any buttons to send the scene number.

—Parameter "Scene NO."

This parameter is visible when previous parameter is enabled. Set the sending scene number, corresponding telegram is 0~63. Options:

Scene NO.1

...

Scene NO.64

5.2.2. Parameter window "Brightness setting"

Screen brightness in normal mode	100	%
Screen brightness in night mode	30	%
Screen brightness can be changed via bus	<input checked="" type="checkbox"/>	
Delay time for turn off screen at day [0..255]	30	s
Delay time for turn off screen at night [0...200]	30	s
Button command execute when screen is off	<input checked="" type="checkbox"/>	
Behaviour of waking up screen when proximity trigger or button operation	<input checked="" type="radio"/> Enter screen saver page <input type="radio"/> Enter function page	

Fig.5.2.2 Parameter window "Brightness setting"

Parameter "Screen brightness in normal mode"

This parameter is for setting the screen brightness level when normal or day mode (some one proximity/operation). Options:

- 20%**
- ...
- 90%**
- 100%**

User can change brightness via object "Screen brightness". Voltage failure or exit day mode, the new brightness value will also be stored.

Parameter "Screen brightness in night mode"

This parameter is visible when night mode is enabled. Set the the screen brightness level when night mode (some one proximity/operation). Options:

- 20%**
- ...
- 90%**
- 100%**
- Unchanged**

User can change brightness via object "Screen brightness". Voltage failure or exit night mode, the

new brightness value will also be stored.

When “Unchanged” is selected, the brightness remains at the brightness of day mode, user can only change the brightness temporarily via the object. Voltage failure or exit night mode, the new brightness value will be not stored.

Parameter “Screen brightness can be changed via bus”

This parameter is for setting whether the screen brightness can be changed via bus.

If enabled, the object “Screen brightness” is visible. It is only used to change the brightness of current status. E.g. if it is currently day mode, only the brightness settings in day mode are updated.

Brightness of screen saver can not be changed via the object.

Parameter “Delay time for turn off screen[0...255]”

Parameter “Delay time for turn off screen[0...255] at day”

Parameter “Delay time for turn off screen[0...200] at night”

This parameter is for setting the delay time that off screen after no operation or enter screen saver.

When night mode is disabled, options: **0..255 s**

When night mode is enabled, options at day: **0..255 s**; options at night: **0..200 s**

When the value is 0, there is a object “Screen on/off” for controlling on/off screen via bus.

Note: When the value is 0, display red box warning, as shown as follow:

 Note: It is only recommend that this option is used for demonstration purpose,screen may be damaged when permanent on for long time

Parameter “Button command execute when screen is off”

This parameter is for setting whether the button command is executed when screen is off.

Parameter “Send extension scene command when screen is off”

Parameter “Send extension scene command when screen is off at day”

Parameter “Send extension scene command when screen is off at night”

These parameter are for setting whether to enable send extension scene command when screen is off, you can set the scene number and scene object when enabled. If night mode is enabled, the scene numbers at day/night can be configured independently.

When the screen is off, operate any buttons to send the scene number.

—Parameter“Scene NO.”

This parameter is visible when previous parameter is enabled. Set the sending scene number, corresponding telegram is 0~63. Options:

Scene NO.1

Scene NO.2

Scene NO.3

...

Scene NO.64

Parameter“Wake up screen when proximity trigger or button operation after turn off via bus”

This parameter is visible when delay time for turn off is set to 0. Set whether to wake up screen when proximity trigger or button operation after turn off via bus.

—Parameter“Delay time for automatically turn off screen again[0...255]”

This parameter is visible when previous parameter is enabled. Set the delay time for automatically turn off screen again. When the value is 0, there is a object “Screen on/off” for controlling on/off screen via bus. Options: **0..255 s**

Parameter“Behaviour of waking up screen when proximity trigger or button operation”

This parameter is for setting the behaviour of waking up screen when proximity trigger or button operation. Options:

Enter screen saver page

Enter function page

When the function of screen saver is disabled, “Enter screen saver page” is not visible.

5.2.3. Parameter window“Screen saver setting”

Screen brightness in screen saver	50	%
Delay time for normal to screen saver [5..255]	30	s
Items 1 display function	Int. temperature	
Function icon	Temperature	
Colour for Items 1	Red	
Text for unit	°C	
Items 2 display function	Int. temperature	
Function icon	Temperature	
Colour for Items 2	Red	
Text for unit	°C	
Items 3 display function	Int. temperature	
Function icon	Temperature	
Colour for Items 3	Red	
Text for unit	°C	
Time period for request external sensor [0..255]	0	min

Fig.5.2.3 “Screen saver setting” Parameter window

Parameter“Screen brightness in screen saver”

This parameter is for setting screen brightness level in screen saver. Options:

- 20%**
- 30%**
- 40%**
- 50%**

Parameter“Delay time for normal to screen saver [5..255]”

This parameter is for setting the delay time for normal mode to screen saver. Options: **5..255 s**

Parameter“Items x display function” (x=1~3)

This parameter is for setting the item that is displayed in screen saver, up to 3 items.

Options:

None	2byte unsigned value
Int. temperature	2byte float value
Ext. temperature	4byte unsigned value
Ext. humidity	4byte float value
1bit value	14byte string
1byte percent value	Fixed string
1byte unsigned value	

Note: 1.Horizontal display mode: With icons/Without icons, text displayed in 2 lines. If content exceeds display area, scroll by line.

2.Vertical display mode: With icons, text displayed in 2 lines; Without icons, text displayed in up to 5 lines. If content exceeds display area, scroll by line.

3.Except for 14-byte strings, all other strings support a maximum display length of 6 bytes, which is approximately 6 English characters or 3 Chinese characters; actual display may vary. For 14-byte strings, the maximum display length is approximately 32 English characters or 10 Chinese characters; actual display may vary.

Parameters as follow are not visible when "None" is selected. There is no the option "None" for item 1:

Parameter "Function icon"

This parameter is for setting the function icon displayed on the screen saver. Options:

- None**
- Brighter**
- Darker**
- ...**
- Rain**

The icons corresponding to the options are described in the appendix, please refer to [Chapter 7](#).

Parameter "Colour for Items x"

This parameter is for setting the text colour displayed on the screen saver.

Options:

Red	Cyan
Dark green	Coffee
Blue	Light orange
Yellow	Customized colour 1
Orange	Customized colour 2
Purple	Customized colour 3
Grey	Customized colour 4
Pink	Customized colour 5
Cyan blue	

Parameter "Status text for 1-ON"

Parameter "Status text for 0-OFF"

These parameters are visible when "1bit" is selected. Set the text to display when telegram 0 and 1.

Parameter "Text for unit"

This parameter is for setting the text for unit. When "temperature or humidity", read only °C/°F or %; while "1byte/2byte/4byte" is selected, the unit is customizable.

Parameter "Decimal place"

This parameter is visible when "2byte float value" or "4byte float value" is selected. Set the decimal place for float value. Options:

0

1

Note: temperature and humidity have 1 decimal place by default.

Parameter "Display content"

This parameter is visible when "fixed string" is selected. Set the custom display content.

Parameter "Time period for request external sensor [0..255]"

This parameter is for setting the time period for device to send a control value read request to external sensor after bus recovery or finish programming. Not send when value is 0.

Options: **0..255 min**

5.2.4. Parameter window "Night mode setting"

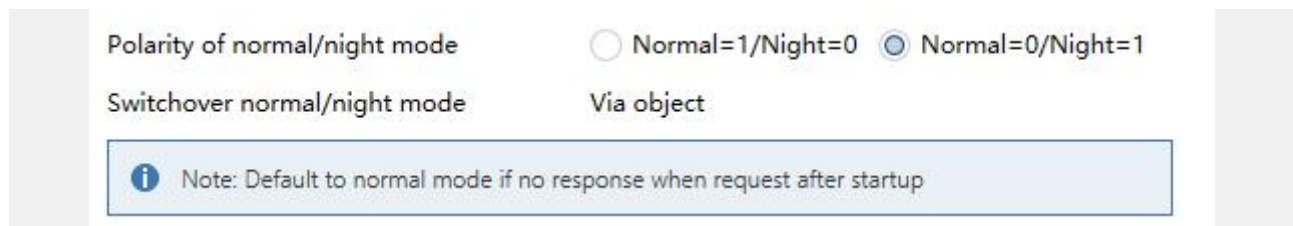

Fig.5.2.4 "Night mode setting" Parameter window

Parameter "Polarity of normal/night mode"

This parameter for setting object value of normal/night mode. Options:

Normal=1/Night=0

Normal=0/Night=1

Parameter "Switchover normal/night mode"

This parameter for setting the switchover way of normal/night status, send status telegrams via object "Night mode" when status change. Read only the option **Via object**

Note: Default to normal mode if no response when request after startup

Note: default to normal mode if no response when request after startup. That is, screen backlight and LED status indication are according to normal (day) mode to display.

5.2.5. Parameter window“RGB light setting”

RGB light setting	Independent configuration
Brightness level in normal mode	Level 5
Brightness level in night mode	Level 5
Brightness level in screen saver	Level 1
<hr/>	
Indication work mode when active	Slowly breathing
Colour setting	Purple
Indication object trigger polarity	<input checked="" type="radio"/> 0=no trigger/1=trigger <input type="radio"/> 1=no trigger/0=trigger
Initial after device startup	<input checked="" type="radio"/> No trigger <input type="radio"/> Trigger
Flashing function	<input checked="" type="checkbox"/>
Colour in flashing	Red
Status after turn off screen	<input type="radio"/> Keep current status <input checked="" type="radio"/> OFF

Fig.5.2.5 “RGB light setting” Parameter window

Parameter“RGB light setting”

This parameter is for setting the configuration way of RGB light, read only **Independent configuration**.

Parameter“Brightness level in normal mode”

This parameter is for setting the brightness level of RGB light in normal mode.

Options:

- Level 1**
- Level 2**
- ...
- Level 5**

Parameter“Brightness level in night mode”

This parameter is for setting the brightness level of RGB light in night mode. Options:

- Unchanged**
- Level 1**
- Level 2**
- ...

Level 5

Parameter "Brightness level in screen saver"

This parameter is for setting the brightness level of RGB light in screen saver mode. Options:

OFF

Level 1

Level 2

...

Level 5

Parameter "Indication work mode when active"

This parameter is for setting the work mode of RGB light.

Options:

Permanent on

Slowly breathing

Color range cycle

Slowly breathing: 5s on 25s off, indication cyclically.

Colour range cycle: display in the order of red / green / blue / white / yellow / cyan / purple / orange / cyan blue in a cycle.

—Parameter "Interval time of colour shift [3..255]s"

This parameter is visible when previous parameter is selected "Colour range cycle". Set the interval time of colour shift. Options: **3..255**

Parameter "Indication object trigger polarity"

This parameter is for setting the trigger polarity of 1bit indication object. Options:

0=no trigger/1=trigger

1=no trigger/0=trigger

Parameter "Initial after device startup"

This parameter is for setting the initial trigger status of 1bit indication object after device startup.

Options:

No trigger

Trigger

—Parameter "Colour setting"

This parameter is visible when the work mode of RGB light is selected "Permanent on" or "Slowly breathing". Set the indication colour for RGB light. Options:

OFF	Cyan
Red	Coffee
Dark green	Light orange
Blue	Customized colour 1
Yellow	Customized colour 2
Orange	Customized colour 3
Purple	Customized colour 4
Grey	Customized colour 5
Pink	Receive a 3byte value
Cyan blue	

Parameter "Flashing function"

This parameter is for setting whether to enable flashing function.

—Parameter "Colour in flashing"

This parameter is visible when previous parameter is enabled. Set the indication colour for RGB light when flashing. Options:

OFF	Cyan blue
Red	Cyan
Dark green	Coffee
Blue	Light orange
Yellow	Customized colour 1
Orange	Customized colour 2
Purple	Customized colour 3
Grey	Customized colour 4
Pink	Customized colour 5

Note: The flashing function is used as an alarm indication and has a higher priority than the normal display, if it is triggered, the light will flash and revert to the normal display once the flashing

stops. The flashing frequency is 2.5s on and 2.5s off, and the flashing colour can be configured via the parameter, flashing brightness is 100%.

Parameter "Status after turn off screen"

This parameter is for setting the indication status of RGB light after turn off screen. Options:

Keep current status

OFF

5.2.6. Parameter window "Proximity setting"

The Proximity function triggered via	Sensor
Proximity Sensitivity	Low
Object type of output value	1bit[On/Off]
Output value	<input type="radio"/> OFF <input checked="" type="radio"/> ON
Delay time for sending [0..65535]	0 s
Whether button operation also serve as a proximity event	<input checked="" type="checkbox"/>

Fig.5.2.6 "Proximity setting" Parameter window

Parameter "The Proximity function triggered via"

This parameter is for setting the trigger way of proximity function. Options:

Sensor

Proximity object

Sensor or Proximity object

When "Sensor or Proximity object" is selected, not send output value when proximity triggered via object.

Parameters as follow are visible when "Sensor" or "Sensor or Proximity object" is selected:

Parameter "Proximity Sensitivity"

This parameter is for setting the sensor sensitivity.

Low is approximately 30cm; Medium is approximately 70cm; High is approximately 120cm;

Accuracy: +/-10 cm.

Options:

Low

Medium

High

Note: After the device is powered on or restarted, the first approach will automatically block the sensing area within 10 cm in front of the device. Once the device detects an approach and leave action, the above blocking area will be lifted.

Parameter "Object type of output value"

This parameter is for setting the object type of output value sent to the bus when proximity is

triggered. Options:

No reaction

1bit[On/Off]

1byte[scene control]

1byte[0..255]

1byte[0..100%]

2byte[0..65535]

Parameters as follow are visible when “No reaction” is not selected:

——Parameter“Output value”

This parameter is for setting the output value sent to the bus when proximity approaching/leaving, the range of value is determined by the data type.

——Parameter“Delay time for sending [0..65535]”

This parameter is for setting the delay time for sending telegram. Options: **0..65535 s**

Note: During the delay time for sending telegram, multiple approaching/leaving will not trigger repeated telegram.

Parameter“Whether button operation also serve as a proximity event”

This parameter is for setting whether button operation also serve as a proximity event.

If disabled, button operation only for waking up the screen or executing the button function, but not to send proximity telegram, and only it is sent when the proximity sensor is triggered.

If enabled, the proximity telegram is sent via triggering the proximity sensor, operating button can also.

5.2.7. Parameter window“Advanced setting”



Fig.5.2.7 “Advanced setting” Parameter window

Parameter“Logic function”

When this parameter is enabled, the “Logic function” is visible. This function is described in detail in [chapter 5.5](#).

Parameter“Scene group function”

When this parameter is enabled, the “Scene group function” is visible. This function is described in detail in [chapter 5.6](#).

5.3. Parameter window“Internal temperature measurement”

Temperature calibration	0.0	K
Send temperature when the result change by	1.0	K
Cyclically send temperature [0...255,0=inactive]	10	min
Send alarm telegram for low/high temperature	Respond after read only	
Threshold value for low temperature alarm [0..15]	0	°C
Threshold value for high temperature alarm [30..45]	45	°C

Fig.5.3 “Internal temperature measurement” Parameter window

The following parameters is used for setting the calibration value, sending condition and error report of internal sensor. If internal sensor is selected for other functions as well, please refer to this section.

Parameter“Temperature calibration”

This parameter is for setting the temperature calibration value of the internal sensor, that is, to calibrate the measured value of internal sensor to make it closer to the current ambient temperature.

Options:

- 5.0K
- ...
- 0.0K
- ...
- 5.0K

Note: after the device is powered on, the stability time of internal sensor detection will take 30 minutes, therefore, the detected temperature value in the early stage of device work may be inaccurate.

Parameter“Send temperature when the result change by”

This parameter is for setting when temperature turns to a certain value, whether to enable to send the current temperature value to the bus. Not send when disable. Options:

- Disable
- 0.1K

0.2K

0.3K

0.5K

1.0K

...

10K

Parameter "Cyclically send temperature [0..255,0=inactive]"

This parameter is for setting the time for cyclically sending the temperature detection value to the bus.

Options: **0..255 min**

This period is independent and starts time counting after programming completion or reset.

Transmission change has no affect on this period.

Parameter "Send alarm telegram for low/high temperature"

This parameter is for setting condition of sending telegram when low/high temperature alarm.

Options:

No respond

Respond after read only

Respond after change

Respond after read only: Only when the device receives a read alarm from other bus device or bus will the object "Low temperature alarm"/" High temperature alarm" send the alarm status to the bus.

Respond after change: the object "Low temperature alarm"/"High temperature alarm" will immediately send the telegram to the bus to report the alarm value when the alarm status has changed.

Parameters as follow are visible when "Respond after read only" or "Respond after change" is selected:

—Parameter "Threshold value for low temperature alarm [0..15]"

This parameter is for setting the threshold value for low temperature alarm. When the temperature lower than low threshold, low temperature alarm object will send telegram. Options:

0°C

1°C

...

15°C

—Parameter“Threshold value for high temperature alarm [30..45]”

This parameter is for setting the threshold value for high temperature alarm. When the temperature higher than high threshold, high temperature alarm object will send telegram. Options:

30°C

31°C

...

45°C

Note: When the parameter “Send alarm telegram for low/high temperature” is set to “No respond”, the default hysteresis value is $\pm 2^\circ\text{C}$. When set to “Respond after read only” or “Respond after change”, there is no hysteresis value.

5.4. Parameter window "Function setting"

Function type Multifunction thermostat Audio control

Room temperature control function 1 as Disable

Room temperature control function 2 as Disable

Floor heating function

Interface preview



Button 1	NA	Button 2	NA
Button 3	short press to increase temperature once, long press to increase temperature continuously at 0.5s intervals	Button 4	short press to decrease temperature once, long press to decrease temperature continuously at 0.5s intervals
Button 5	if enable multiple functions, press to switchover function page	Button 6	press to switch power on/off

Ventilation function

Interface preview



Button 1	short press to switch mode, long press to switch heat recovery status	Button 2	short press to switch auto status, long press to reset filter time
Button 3	short press to increase fan speed level once, long press to increase fan speed level	Button 4	short press to decrease fan speed level once, long press to decrease fan speed

Fig.5.4 "Function setting" Parameter window

Parameter "Function type"

This parameter is for setting the function type of the panel. Options:

Multifunction thermostat

Audio control

Parameters as follow are visible when "Multifunction thermostat" is selected:

Parameter "Room temperature control function 1/2 as"

This parameter is for setting whether to enable the setting interface of room temperature control function, FCU control and VRF control can only choose one of them, select to display corresponding interface. Options:

Disable

FCU control

VRF control

Parameter "Interface preview: FCU"

This parameter is visible when "FCU control" is selected. Set the panel preview image and the button descriptions for FCU control.

Vertical:

Button 1	Short press to switch fan speed, long press to switch auto status	Button 2	If operation mode disable, press to switch heating/cooling mode; if operation mode enable, short press to switch operation mode, long press to switch heating/cooling mode
Button 3	Short press to decrease temperature once, long press to decrease temperature continuously at 0.5s intervals	Button 4	Short press to increase temperature once, long press to increase temperature continuously at 0.5s intervals
Button 5	Press to switch power on/off	Button 6	If enable multiple functions, press to switchover function page

Horizontal:

Button 1	If operation mode disable, press to switch heating/cooling mode; if operation mode enable, short press to switch operation mode, long press to switch heating/cooling mode	Button 2	Short press to switch fan speed, long press to switch auto status
Button 3	Short press to increase temperature once, long press to increase temperature continuously at 0.5s intervals	Button 4	Short press to decrease temperature once, long press to decrease temperature continuously at 0.5s intervals
Button 5	If enable multiple functions, press to switchover function page	Button 6	Press to switch power on/off

Parameter "Interface preview: VRF"

This parameter is visible when "VRF control" is selected. Set the panel preview image and the button descriptions for VRF control.

Vertical:

Button 1	Short press to switch fan speed, long press to switch swing status	Button 2	Press to switch mode
Button 3	Short press to decrease temperature once, long press to decrease temperature continuously at 0.5s intervals	Button 4	Short press to increase temperature once, long press to increase temperature continuously at 0.5s intervals
Button 5	Press to switch power on/off	Button 6	If enable multiple functions, press to switchover function page

Horizontal:

Button 1	Press to switch mode	Button 2	Short press to switch fan speed, long press to switch swing status
Button 3	Short press to increase temperature once, long press to increase temperature continuously at 0.5s intervals	Button 4	Short press to decrease temperature once, long press to decrease temperature continuously at 0.5s intervals
Button 5	If enable multiple functions, press to switchover function page	Button 6	Press to switch power on/off

Parameter "Floor heating function"

This parameter is for setting whether to enable the setting interface of floor heating function, select to display corresponding interface.

Parameter "Interface preview"

This parameter is for setting the panel preview image and the button descriptions for floor heating function.

Vertical:

Button 1	NA	Button 2	NA
Button 3	Short press to decrease temperature once, long press to decrease temperature continuously at 0.5s intervals	Button 4	Short press to increase temperature once, long press to increase temperature continuously at 0.5s intervals
Button 5	Press to switch power on/off	Button 6	If enable multiple functions, press to switchover function page

Horizontal:

Button 1	NA	Button 2	NA
Button 3	Short press to increase temperature once, long press to increase temperature continuously at 0.5s intervals	Button 4	Short press to decrease temperature once, long press to decrease temperature continuously at 0.5s intervals
Button 5	If enable multiple functions, press to switchover function page	Button 6	Press to switch power on/off

Parameter "Ventilation function"

This parameter is for setting whether to enable the setting interface of ventilation function, select to display corresponding interface.

Parameter "Interface preview"

This parameter is for setting the panel preview image and the button descriptions for ventilation function.

Vertical:

Button 1	Short press to switch mode, long press to reset filter time	Button 2	Short press to switch auto status, long press to switch heat recovery status
Button 3	Short press to decrease fan speed level once, Long press to decrease fan speed level continuously at 0.5s intervals	Button 4	Short press to increase fan speed level once, Long press to increase fan speed level continuously at 0.5s intervals
Button 5	Press to switch power on/off	Button 6	If enable multiple functions, press to switchover function page

Horizontal:

Button 1	Short press to switch auto status, long press to switch heat recovery status	Button 2	Short press to switch mode, long press to reset filter time
Button 3	Short press to increase fan speed level once, Long press to increase fan speed level continuously at 0.5s intervals	Button 4	Short press to decrease fan speed level once, Long press to decrease fan speed level continuously at 0.5s intervals
Button 5	If enable multiple functions, press to switchover function page	Button 6	Press to switch power on/off

Parameters as follow are visible when "Audio control" is selected:

Parameter "Interface preview"

This parameter is for setting the panel preview image and the button descriptions for audio control.

Vertical:

Button 1	Press to switch previous track	Button 2	Short press to switch next track, long press to switch play mode
Button 3	Short press to decrease volume, Long press to decrease volume continuously at 0.5s intervals	Button 4	Short press to increase volume once, Long press to increase volume continuously at 0.5s intervals
Button 5	Short press to switch power on/off	Button 6	Short press to switch play/pause, long press to mute

Horizontal:

Button 1	Press to switch previous track	Button 2	Short press to switch next track, long press to switch play mode
Button 3	Short press to increase volume once, Long press to increase volume continuously at 0.5s intervals	Button 4	Short press to decrease volume, Long press to decrease volume continuously at 0.5s intervals
Button 5	Short press to switch play/pause, long press to mute	Button 6	Short press to switch power on/off

Chapters as follow explain the above functions separately.

5.4.1. Parameter window“FCU setting”

Indication function icon	<input checked="" type="checkbox"/>
Icon	Temperature
Work mode	Single
Room temperature reference from	Internal sensor
Control value after temp. error [0..100] (If 2-point control, set value '0'=0, set value '>0'=1)	0 %
Interface display temperature	<input type="radio"/> Setpoint temperature <input checked="" type="radio"/> Actual temperature
Setpoint temperature adjustment step	<input checked="" type="radio"/> 0.5K <input type="radio"/> 1K
Power on/off function	Via both button and object
Power on/off status after download	<input type="radio"/> OFF <input checked="" type="radio"/> ON
Power on/off status after voltage recovery	As before voltage failure
Room temperature control mode	Cooling
Room temperature operation mode	<input checked="" type="checkbox"/>
Controller status after download	Standby mode
Controller status after voltage recovery	As before voltage failure
Extended comfort mode [0..255,0=inactive]	0 min
Window contact input function	<input checked="" type="checkbox"/>
Delay for window contact [0..65535]	15 s
Operation mode for open window	<input type="radio"/> Economy mode <input checked="" type="radio"/> Frost/heat protection
Bus presence detector function	<input checked="" type="checkbox"/>
Fan	<input checked="" type="checkbox"/>
Scene	<input checked="" type="checkbox"/>
Allow to enable lock function via combined button (Button 2&5)	<input checked="" type="checkbox"/>

Fig.5.4.1 “FCU setting” Parameter window

Parameter "Indication function icon"

This parameter is for setting whether to display the icon of FUC control on the screen.

—Parameter "Icon"

This parameter is visible when previous parameter is enabled, set the function icon.

Parameter "Work mode"

This parameter is for setting the work mode of FCU control. Options:

Single

Master

Slave

Single: the device is a single control in the system and has a temperature control algorithm, the output directly controls the actuator.

Master: the device belongs to multi-control in the system, and the FCU control output is dominated by the device, and has temperature control algorithm. When the device restarts, it sends the current status to the bus, such as power on/off, setpoint temperature, control mode, operation mode, fan speed.

Slave: the device belongs to the slave control in the system, at this time FCU control is only used as touch and display, no temperature control algorithm, when the device restarts, it will send the status read request, such as power on/off, setpoint temperature, control mode, operation mode, fan speed.

Parameter "Room temperature reference from"

This parameter is for setting the resource of the room temperature reference. Options:

Internal sensor

External sensor

Internal and External sensor combination

When selecting the reference internal sensor, the temperature is determined by the setting of the "Internal sensor" in the parameter interface, more details refer to [chapter 5.3](#).

—Parameter "Period for request external sensor [0...255]min"

This parameter is visible when "External sensor" or "Internal and External sensor combine" is

selected. Set the time period for read request external temperature sensor. Options: **0..255**

Parameters as follow are visible when “Internal sensor combine with External sensor” is selected:

—Parameter“Combination ratio”

This parameter is for setting the internal sensor and the external sensor to measure the specific gravity of the temperature. Options:

10% Internal to 90% External

20% Internal to 80% External

...

90% Internal to 10% External

For example, if the option is “40% internal to 60% external”, then the internal sensor accounts for 40%, the external sensor accounts for 60%, and the control temperature = (internal sensor's temperature × 40%) + (external sensor's temperature × 60%), the RTC function of the device will control and display the temperature according to the calculated temperature.

When two sensors are combined for detection, when one sensor is in error, the temperature value detected by the other sensor is used.

—Parameter“Send temperature when the result change by”

This parameter is for setting when temperature turns to a certain value, whether to enable to send the current temperature value to the bus. No telegram is sent when Disable is selected. Options:

Disable

0.5K

1.0K

...

10.0K

—Parameter“Cyclically send temperature [0...255]min”

Setting the time for cyclically sending the temperature detection value to the bus. No telegram is sent when value is 0. Options: **0..255**

Note: cyclically sending and change sending are independent of each other.

Parameter "Control value after temp. error[0..100]% (if 2-point control, set value '0'=0, set value '>0'=1)"

When the work mode is "Slave", this parameter is not visible. Set the custom display content.

Options: **0..100**

If 2-Point control, then the parameter value is 0, as well as the control value; if the parameter value is more than 0, then the control value will be 1.

Parameter "Interface display temperature"

This parameter is for setting the interface display temperature under the normal status. Options:

Setpoint temperature

Actual temperature

If display actual temperature, it just to wake up when firstly adjust setpoint temperature, and not send telegram.

Parameter "Setpoint temperature adjustment step"

This parameter is for setting step value of setpoint temperature. Options:

0.5K

1K

Parameter "Min./Max. setpoint temperature [5..37]°C"

These parameters are for setting the adjustable range of the setpoint temperature, the minimum value should be less than the maximum value. Options:

Options:

5°C

6°C

...

37°C

If the setpoint temperature beyond the limited range, it will output the limited temperature.

For setpoint temperature, the Min. value must less than the Max., if not, it can not be modified on ETS.

Parameter "Power on/off function "

This parameter is for setting whether to enable power on/off function of controller. Options:

Disable

Via button only

Via object only

Via both button and object

Parameter "Power on/off status after download "

When the work mode is "Slave", this parameter is not visible. Set the power on/off status of FCU control interface after download. Options:

OFF

ON

Parameter "Power on/off status after voltage recovery "

When the work mode is "Slave", this parameter is not visible. Set the power on/off status of FCU control interface after device voltage recovery. Options:

OFF

ON

As before voltage failure

OFF: FCU control interface is off when device is powered on, this interface is not operational, and FCU is not going to calculate;

ON: FCU control interface is on when device is powered on, this interface is operational, FCU will calculate internally according to the control type to determine the current controlling status;

As before voltage failure: FCU control interface will recover to the status before voltage failure, if it is on, then FCU will calculate internally according to the control type to determine the current controlling status.

Parameter "Room temperature control mode"

This parameter is for setting room temperature control mode. Options:

Heating

Cooling

Heating and Cooling

Parameters as follow are visible when “Heating and Cooling” is selected:

—Parameter “Heating/Cooling switchover”

This parameter is for setting the switchover way of Heating/Cooling. Options:

Only via button

Only via object

Via both button and object

Automatic changeover

When the work mode is “Slave”, read only the option “Only via object”.

—Parameter “Heating/Cooling status after download”

When the work mode is “Slave”, this parameter is not visible. Set the heating/cooling control mode of device after download. Options:

Heating

Cooling

—Parameter “Heating/Cooling status after voltage recovery”

When the work mode is “Slave”, this parameter is not visible. Set the heating/cooling control mode of device after voltage recovery. Options:

Heating

Cooling

As before voltage failure

As before voltage failure: When the device is reset after power on, the control mode will recover as before voltage failure. If it is the first time the device is used or a newly enabled function page, the control mode after the device is started is in an uncertain state, and it needs to be manually selected at this time.

—Parameter “Room temperature control system”

When the work mode is “Slave”, this parameter is not visible. Set the type of room temperature control system, that is, pipe types of fan coil water inlet/outlet. Options:

2 pipes system

4 pipes system

2 pipes system: Shares an inlet and outlet pipe for heating and cooling, that is, both hot and cold water are controlled by a valve.

4 pipes system: Has its own inlet and outlet pipes for heating and cooling, and two valves are needed to control the entry and exit of hot water and cold water respectively.

Parameter "Room temperature operation mode"

This parameter is for setting whether to enable room temperature operation mode.

When enable, support 4 modes with comfort, standby, economy and frost/heat protection. Support datatype of 1byte, and preset a operation mode when download and voltage recovery.

Parameters as follow are visible when room temperature operation mode enabled:

——Parameter "Controller status after download"

When the work mode is "Slave", this parameter is not visible. Set the operation mode when power on FCU after download. Options:

Standby mode

Comfort mode

Economy mode

——Parameter "Controller status after voltage recovery"

When the work mode is "Slave", this parameter is not visible. Set the operation mode when power on FCU after voltage recovery. Options:

Comfort mode

Standby mode

Economy mode

Frost/heat protection

As before voltage failure

—Parameter“Extended comfort mode [0..255,0=inactive]min”

When the work mode is “Slave”, this parameter is not visible. Set the extended time of comfort mode. When value >0, activate the extended, and 1 bit object “Extended comfort mode” is visible.

Options: **0..255**

When object receives telegram 1, comfort mode activation. If receive telegram 1 again during the delay time, the time is retiming. And comfort mode will return to previous operation mode once finish the timing. Exit the comfort mode when a new operation mode in delay time.

Change the operation mode will quit the timing, and heating/cooling switchover will not.

—Parameter“1 bit object function for operation mode”

When the work mode is“Master”, this parameter is visible.

Set whether to enable 1 bit object function for operation mode.

When enabled, the 1 bit object function for operation mode is visible, send telegram 1 to activate corresponding mode.

If receive the telegram 0 of comfort, economy and protection mode from the bus, current mode will be updated to standby mode.

—Parameter“1 bit object for standby mode”

This parameter is visible when previous parameter is enabled. Set whether to enable 1 bit object for standby mode.

When enabled, the 1 bit object function for standby mode is visible.

Parameters as follow are visible when room temperature operation mode disabled:

—Parameter“Initial setpoint temperature (°C)”

When the work mode is “Slave”, this parameter is not visible. Set the initial value of setpoint temperature. Options:

10.0

10.5

...

35.0

Note: When the initial temperature value is lower than the set minimum value or higher than the set maximum value, it cannot be set on the ETS.

Automatic H/C mode changeover dead zone

—Parameter“ Upper/Lower dead zone”

When the work mode is “Slave”, these two parameters are not visible.

These two parameters are visible when control mode“Heating and Cooling” is selected, and “Automatic changeover” is selected. Setting the dead zone range of auto switchover heating/cooling.

Options:

0.5K

1.0K

...

10.0K

Under heating control, when the actual temperature(T) greater than or equal to the setpoint temperature + the upper dead zone, then mode heating switch to cooling;

Under cooling control, when the actual temperature(T) less than or equal to the setpoint temperature + the upper dead zone, then mode cooling switch to heating.

Parameter“Window contact input function”

When the work mode is “Slave”, this parameter is not visible.

This parameter is visible when room temperature operation mode is enabled. Set whether to link to window contact status.

When window contact input function is enabled, these two parameters as follow are visible:

—Parameter“Delay for window contact [0..65535]s”

This parameter is for setting the delay time to window contact detection. That is, when receive a telegram “Open window”, the controller will regard that as a valid signal and execute the behaviour after this delay time.

Options: **0..6553**

—Parameter “Controller mode for open window”

If window status is open, perform corresponding operation according to configuration. (Other control telegram receiving will be record during window is open and performed after receiving the telegram “Close window”. If there is no telegram receiving when window is open, return to the mode before opening the window) Options:

Economy mode

Frost/heat protection

Parameter “Bus presence detector function”

When the work mode is “Slave”, this parameter is not visible.

This parameter is visible when room temperature operation mode is enabled. Set whether to link to bus presence detector status.

If presence is detected, enter the comfort mode and recovery original mode after leaving. If there is a telegram/manual to adjust the mode, it will not recovery the previous mode after leaving. (If receive presence status cyclically, no comfort mode retriggered, and only can be after leaving.)

Parameter “Fan”

This parameter is for setting whether to enable fan control interface is visible.

Parameter “Scene”

When the work mode is “Slave”, this parameter is not visible. Set whether to enable timer function. When enabled, the bus can disable timer function temporarily, initial status is off.

Parameter “Allow to enable lock function via combined button (Button 2&5)”

This parameter is for setting whether to enable lock function via combined button. When enabled, long press button 2 and button 5 simultaneously to lock/unlock the panel. This function does not affect the switch button, all other buttons will be disabled.

The long press time is set by the parameter “long operation for button after [5..250]”.

5.4.1.1. Parameter window "Setpoint"

Setpoint method for operating mode	<input checked="" type="radio"/> Relative <input type="radio"/> Absolute
Base setpoint temperature	20.0 °C
Automatic H/C mode changeover dead zone (only for comfort mode)	
Upper dead zone	2.0 K
Lower dead zone	2.0 K
<hr/>	
Heating	
Reduced heating in standby mode [0..10]	2 K
Reduced heating in economy mode [0..10]	4 K
Setpoint temperature in frost protection [5..10]	7 °C
Cooling	
Increased cooling in standby mode [0..10]	2 K
Increased cooling in economy mode [0..10]	4 K
Setpoint temperature in heat protection [30..37]	35 °C
<hr/>	
Min. setpoint temperature [5..37]	10 °C
Max. setpoint temperature [5..37]	32 °C

Relative

Setpoint method for operating mode Relative Absolute

Heating

Setpoint temperature in comfort mode [5..37] 21 °C

Setpoint temperature in standby mode [5..37] 19 °C

Setpoint temperature in economy mode [5..37] 17 °C

Setpoint temperature in frost protection [5..10] 7 °C

Cooling

Setpoint temperature in comfort mode [5..37] 23 °C

Setpoint temperature in standby mode [5..37] 25 °C

Setpoint temperature in economy mode [5..37] 27 °C

Setpoint temperature in heat protection [30..37] 35 °C

Note: The heating setpoint must be always less than the cooling setpoint.

Min. setpoint temperature [5..37] 10 °C

Max. setpoint temperature [5..37] 32 °C

Absolute

Fig.5.4.1.1 "Setpoint" Parameter window

When the work mode is "Slave", this parameter window is not visible.

This parameter window is visible when operation mode is enabled, and display according to control mode.

Parameter "Setpoint method for operating mode"

This parameter is for setting the setpoint method for operating mode. Options:

Relative

Absolute

Relative: relative adjustment, the setpoint temperature of economy mode and standby mode will refer to the defined temperature setpoint.

Absolute: absolute adjustment, each mode has its independent temperature setpoint.

Parameters as follow are visible when the setpoint temperature adopts the relative adjustment method:

Parameter "Base setpoint temperature (°C)"

This parameter is for setting the basic setpoint temperature, from which the initial setpoint temperature of the room comfort mode is obtained. Options:

10.0

10.5

...

35.0

The setpoint value will be modified through object "Base setpoint adjustment", then the new value will be stored after the device power off.

Note: When the base setpoint temperature is lower than the set minimum value or higher than the set maximum value, it cannot be set on the ETS.

Automatic H/C mode changeover dead zone (only for comfort mode)

Parameter "Upper/Lower dead zone"

These two parameters are visible when control mode "Heating and Cooling" is selected, and "Automatic changeover" is selected. Set the dead zone range of auto switchover heating/cooling.

Options:

0.5K

1.0K

...

10.0K

Under heating control, when the actual temperature(T) > or = the setpoint temperature + the upper dead zone, then mode heating switch to cooling;

Under cooling control, when the actual temperature(T) < or = the setpoint temperature + the upper dead zone, then mode cooling switch to heating.

Heating/Cooling

Parameter "Reduced heating in standby mode [0...10]K"

Parameter "Increased cooling in standby mode [0...10]K"

These two parameters are for setting the setpoint temperature in standby mode when heating or cooling. Options:

0K

1K

...

10K

Heating: The setpoint of standby mode is the temperature setpoint minus the reference value.

Cooling: The setpoint of standby mode is the temperature setpoint plus the reference value.

Parameter "Reduced heating in economy mode [0...10]K"

Parameter "Increased cooling in economy mode [0...10]K"

These two parameters are for setting the setpoint temperature in economy mode when heating or cooling. Options:

0K

1K

...

10K

Heating: The setpoint of economy mode is the temperature setpoint minus the reference value.

Cooling: The setpoint of economy mode is the temperature setpoint plus the reference value.

Parameter "Setpoint temperature in frost protection mode [5...10]°C"

This parameter is for setting the setpoint temperature in frost protection mode. Options:

5°C

6°C

...

10°C

Under the frost protection mode, when room temperature reduce to the setpoint, the controller will

trigger a control telegram so that related heating controller will output heating control to prevent the temperature from being too low.

Parameter "Setpoint temperature in heat protection mode [30...37]°C"

This parameter is for setting the setpoint of heat protection mode. Options:

30°C

31°C

...

37°C

Under the heat protection mode, when room temperature raise to the setpoint, the controller will trigger a control telegram so that related cooling controller will output cooling control to prevent the temperature from being too high.

Parameters as follow are visible when the setpoint temperature adopts the absolute adjustment method.

Heating/Cooling

Parameter "Setpoint temperature in comfort mode [5...37]°C"

Parameter "Setpoint temperature in standby mode [5...37]°C"

Parameter "Setpoint temperature in economy mode [5...37]°C"

These parameters are for setting the setpoint temperature in comfort/standby/economy mode when heating or cooling. Options:

5°C

6°C

...

37°C

Parameter "Setpoint temperature in frost protection mode [5...10]°C"

This parameter is for setting the setpoint temperature in frost protection mode when heating.

Options:

5°C

6°C

...

10°C

Parameter "Setpoint temperature in heat protection mode [30...37]°C"

This parameter is for setting the setpoint temperature in heat protection mode when cooling.

Options:

30°C

31°C

...

37°C

 Note: The heating setpoint must be always less than the cooling setpoint.

For absolute adjustment mode, when "Heating and Cooling" is selected, whether it is manual changeover, either bus changeover or automatic changeover, the heating setpoint value must be less than or equal to the cooling of the same operation mode, if not, it can not be modified on ETS.

1. When the ambient temperature is higher than the setpoint temperature of current mode in cooling, it is changed to cooling mode; When the ambient temperature is lower than the setpoint temperature of current mode in heating, it is changed to heating mode.

2. In the same operation mode, the setpoint temperature difference between cooling and heating remains constant, whether it is written on the bus or adjusted on the panel. That is, when adjust the setpoint temperature, it need to update cooling and heating setpoint temperature of current operation mode at the same time.

3. When user operates on the panel or the bus is received setpoint temperature, it is still necessary to limit the value according to the high and low thresholds, that is heating and cooling temperature neither can not be lower than the min., or can not be higher than the max.. If parameters configuration of ETS is not met the condition, it can not be modified on ETS.

Note: for relative/absolute adjustment, in protection mode, the setpoint temperature is only configured via ETS, and not limited with the min./max. value. When the received setpoint value from

bus is different from the ETS configuration, the value is not updated and returned to the current setpoint temperature, to update synchronously to other devices on the bus.

5.4.1.2. Parameter window“Heating/Cooling control”

Type of heating control	Switching on/off(use 2-point control)	
Invert control value	<input checked="" type="checkbox"/>	
Lower Hysteresis [0..200]	10	*0.1K
Upper Hysteresis [0..200]	10	*0.1K
<hr/>		
Type of cooling control	Switching on/off(use 2-point control)	
Invert control value	<input checked="" type="checkbox"/>	
Lower Hysteresis [0..200]	10	*0.1K
Upper Hysteresis [0..200]	10	*0.1K
<hr/>		
Cyclically send control value[0..255]	0	min

“Switching on/off(use 2-point control)”

Type of heating control	Switching PWM(use PI control)	
Invert control value	<input checked="" type="checkbox"/>	
PWM cycle time [1..255]	15	min
Heating speed	Hot water heating(5K/150min)	
<hr/>		
Type of cooling control	Switching PWM(use PI control)	
Invert control value	<input checked="" type="checkbox"/>	
PWM cycle time [1..255]	15	min
Cooling speed	Cooling ceiling(5K/240min)	
<hr/>		
Cyclically send control value[0..255]	0	min

“Switching PWM(use PI control)”

Type of heating control	Continuous control(use PI control)
Invert control value	<input checked="" type="checkbox"/>
Heating speed	Hot water heating(5K/150min)
Send control value on change by [0..100,0=inactive]	4 %
<hr/>	
Type of cooling control	Continuous control(use PI control)
Invert control value	<input checked="" type="checkbox"/>
Cooling speed	Cooling ceiling(5K/240min)
Send control value on change by [0..100,0=inactive]	4 %
<hr/>	
Cyclically send control value[0..255]	0 min

"Continuous control(use PI control)"

Fig.5.4.1.2(1) "Heating/Cooling control" Parameter window

When the work mode is "Slave", this parameter window is not visible.

This parameter window displays according to control mode and control system (2 pipe or 4pipe).

Parameter "Type of heating/cooling control"

This parameter is for setting the type of heating/cooling control. Different control types are suitable for controlling different temperature controllers. Options:

Switching on/off(use 2-point control)

Switching PWM(use PI control)

Continuous control(use PI control)

Parameter "Invert control value"

This parameter is for setting whether to invert control value or normal sending control value, so that the control value will be suitable for the valve type.

When enabled, send the control value to the bus through objects after inverting the control value.

These two parameters as follow are suitable for 2 point control:

——Parameter "Lower Hysteresis [0...200]*0.1K "

——Parameter "Upper Hysteresis [0...200]*0.1K "

These two parameters are for setting the lower/upper hysteresis temperature in FCU heating or cooling.

Options: 0..200

Under heating control,

When the actual temperature(T) > the setting temperature + the upper hysteresis temperature, then will stop heating;

When the actual temperature(T) < the setting temperature - the lower hysteresis temperature, then will start heating.

For example, the lower hysteresis temperature is 1K, the upper hysteresis temperature is 2K, the setting temperature is 22°C, if T is higher than 24°C, then it will stop heating; if T is lower than 24°C, then it will start heating; if T is between 21~24°C, then it will maintain the previous status.

Under the cooling control,

When the actual temperature (T) < the setting temperature -the lower hysteresis temperature, then will stop cooling;

When the actual temperature (T) > the setting temperature +the upper hysteresis temperature, then will start cooling.

For example, the lower hysteresis temperature is 1K, the upper hysteresis temperature is 2K, the setting temperature is 26°C, if T is lower than 25°C, then it will stop cooling; if T is lower than 28°C, then it will start cooling; if T is between 28~25°C, then it will maintain the previous status.

2-point control mode is a very simple control mode. When adopting this control mode, it is necessary to set the upper hysteresis temperature and the lower hysteresis temperature through parameters. When setting the hysteresis temperature, the following effects need to be considered

1. When hysteresis interval is small, the temperature range will be small, however, frequent sending of control value will bring large load to the bus;
2. When hysteresis interval is large, the switch switching frequency will be low, but it is easy to cause uncomfortable temperature change.

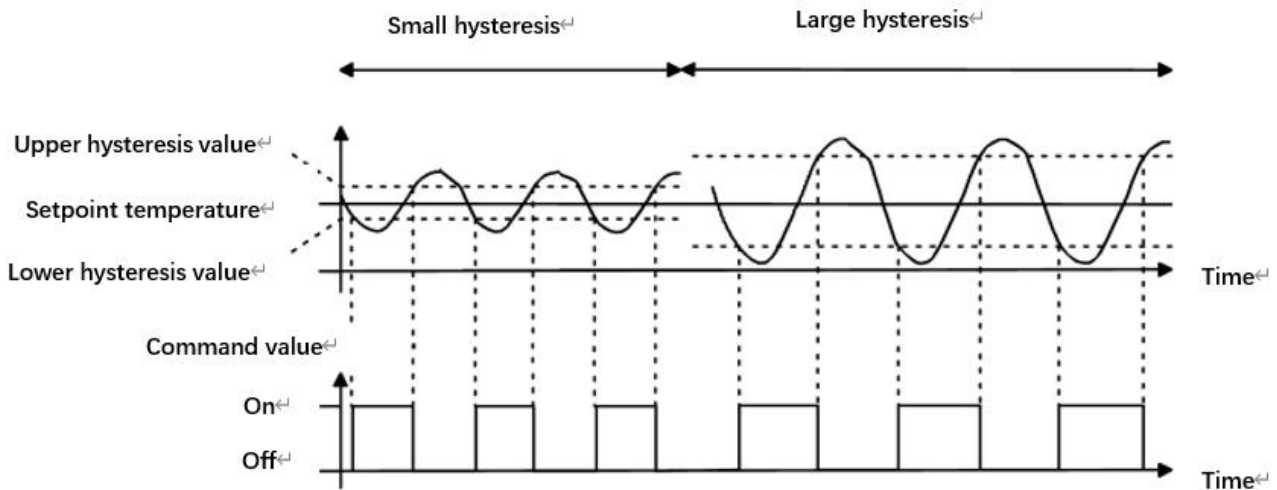

Fig.5.4.1.2(2) Effects of hysteresis on control value switch action(heating) under2-point control mode

These two parameters as follow are suitable for PI control:

——Parameter“PWM cycle time [1...255]min”

This parameter is only visible when the control type is “Switching PWM(use PI control)”. Set the period of the control object cycle to send the switch value, the object sends the switch value according to the duty cycle of the control value. For example, if the set period is 10 min and the control value is 80%, then the object will send an open telegram for 8 min. If the control value is changed, the time duty ratio of the on/ off telegram of the object will also change, but the period is still the time of parameter setting.

Options: **1..255**

The PI values of “Switching PWM (use PI control)” and “Continuous control (use PI control)” are the same, only different in control objects, the control object of “Continuous control” output PI value(1byte) directly, while the control value of “Switching PWM” output a “on/off” telegram according to the duty cycle of the control value.

——Parameter“Heating speed ”

——Parameter“Cooling speed”

These two parameters are for setting the responding speed of heating or cooling controller. Different responding speeds are suitable for different environments.

Options:

- Hot water heating (5K/150min)
- Underfloor heating (5K/240 min)
- Electrical heating (4K/100min)
- Split unit (4K/90min)
- Fan coil unit (4K/90min)
- User defined

Options:

- Cooling ceiling (5K/240min)
- Split unit (4K/90min)
- Fan coil unit(4K/90min)
- User defined

—Parameter“Proportional range [10..100]*0.1K”(P value)

—Parameter“Reset time [0..255]min”(I value)

These two parameters are visible when “User defined” is selected. Set the PI value of PI controller.

Options: **10..100 (P value)**

Options: **0..255 (I value)**

—Parameter“Send control value on change by [0...100,0=inactive]%

This parameter is visible when control type is “Continuous control (use PI control)”, for setting the changing value of the control value to be sent to the bus. Options: **0..100, 0=inactive**

In PI control mode, the predefined control parameters of each PI controller in heating or cooling system are recommended as follows:

(1) Heating

Heating type	P value	I value(integration time)	Recommended PI control type	Recommended PWM period
Hot water Heating	5K	150min	Continuous/PWM	15min

Underfloor heating	5K	240min	PWM	15-20min
Electrical heating	4K	100min	PWM	10-15min
Split unit	4K	90min	PWM	10-15min
Fan coil unit	4K	90min	Continuous	--

(2) Cooling

Cooling type	P value	I value(integration time)	Recommended PI control type	Recommended PWM period
Cooling ceiling	5K	240min	PWM	15-20min
Split unit	4K	90min	PWM	10-15min
Fan coil unit	4K	90min	Continuous	--

(3) User defined

When the parameter "Heating/Cooling speed" is set to "User defined", the parameter value of P (scale factor) and I (integration time) can be set through the parameter. When adjusting the parameters, refer to the fixed PI value mentioned in the above table. Even if the control parameters are adjusted slightly, the control behavior will be significantly different.

In addition, the integration time should be set properly. If the integration time is too long, the adjustment will be slow, and the oscillation will not be obvious; if the integration time is too small, the adjustment will be fast, but the oscillation will occur. 0 means the integral term is not used.

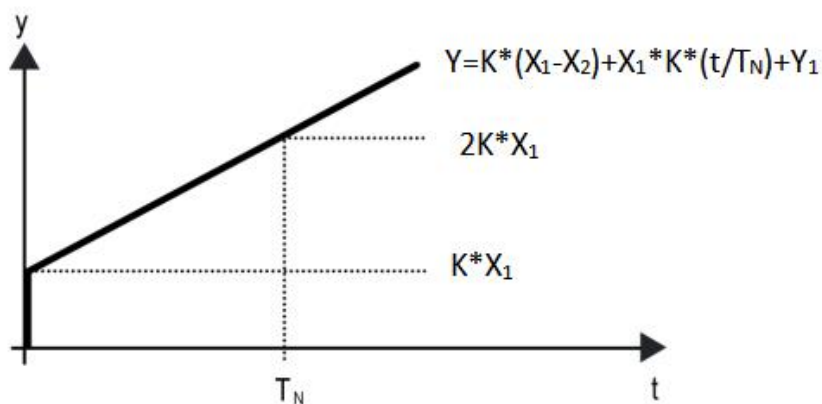

Fig.5.4.1.2 (3) control value of PI control mode

Y: control value

Y1: last control value

X1: temperature deviation = set temperature - actual temperature

X2: last temperature deviation = set temperature - actual temperature

T_N: integration time

K: scale factor (the scale factor is not zero)

PI control algorithm: $Y = K * (X1-X2) + X1 * K * t / T_N + Y1$

When the integration time is set to zero, the PI control algorithm is: $Y = K (X1-X2) + Y2$

Setting and influence of user-defined parameters:

Parameter setting	Effect
K: If the scale range is too small	Quick adjustment, and overshoot will occur
K: If the scale range is too small	Slow adjustment, but no overshoot
T _N : If the integration time is too short	Quick adjustment, but there will be oscillation
T _N : If the integration time is too long	Slow adjustment, no obvious oscillation

Parameter "Cyclically send control value [0...255]min"

This parameter is for setting the period for cyclically sending the control value to the bus.

Options: **0..255**

5.4.1.3. Parameter window“Fan”

Object datatype of 1byte fan speed	<input checked="" type="radio"/> Percentage (DPT_5.001)
	<input type="radio"/> Fan stage (DPT_5.100)
Output value for Fan speed	
Output value for Fan speed low	<input type="text" value="33"/> %
Output value for Fan speed medium	<input type="text" value="67"/> %
Output value for Fan speed high	<input type="text" value="100"/> %
Status feedback for Fan speed	
Status value for Fan speed low	<input type="text" value="33"/> %
Status value for Fan speed medium	<input type="text" value="67"/> %
Status value for Fan speed high	<input type="text" value="100"/> %
Fan speed off via manual operation	<input checked="" type="checkbox"/>
Automatic operation function	Local controller ▾
Fan speed auto control setting	
Condition setting for using 2-point control	
Temperature difference speed OFF<->low [0..200]	<input type="text" value="20"/> *0.1°C
Temperature difference speed low<->medium [1..200]	<input type="text" value="30"/> *0.1°C
Temperature difference speed medium<->high [1..200]	<input type="text" value="40"/> *0.1°C
Hysteresis temperature difference in [0..50]	<input type="text" value="10"/> *0.1°C
Condition setting for using PI control	
Threshold value speed OFF<->low [0..255]	<input type="text" value="80"/>
Threshold value speed low<->medium [1..255]	<input type="text" value="150"/>
Threshold value speed medium<->high [1..255]	<input type="text" value="200"/>
Hysteresis threshold value in +/-[0..50]	<input type="text" value="10"/>
Minimum time in fan speed [0..65535]	<input type="text" value="60"/> s

Fig.5.4.1.3(1) “Fan_Percentage(DPT_5.001)” Parameter window

Object datatype of 1byte fan speed	<input type="radio"/> Percentage (DPT_5.001) <input checked="" type="radio"/> Fan stage (DPT_5.100)
Output value for Fan speed	
Output value for Fan speed low	1
Output value for Fan speed medium	2
Output value for Fan speed high	3
Status feedback for Fan speed	
Status value for Fan speed low	1
Status value for Fan speed medium	2
Status value for Fan speed high	3
Fan speed off via manual operation	<input checked="" type="checkbox"/>
Automatic operation function	Local controller
Fan speed auto control setting	
Condition setting for using 2-point control	
Temperature difference speed OFF<->low [0..200]	20 *0.1°C
Temperature difference speed low<->medium [1..200]	30 *0.1°C
Temperature difference speed medium<->high [1..200]	40 *0.1°C
Hysteresis temperature difference in [0..50]	10 *0.1°C
Condition setting for using PI control	
Threshold value speed OFF<->low [0..255]	80
Threshold value speed low<->medium [1..255]	150
Threshold value speed medium<->high [1..255]	200
Hysteresis threshold value in +/-[0..50]	10
Minimum time in fan speed [0..65535]	60 s

Fig.5.4.1.3(2) "Fan_Fan stage(DPT_5.100)" Parameter window

This parameter window is visible when fan speed control is enabled.

Parameter "Object datatype of 1byte fan speed"

This parameter is for setting the object datatype of 1 byte fan speed. Options:

Percentage (DPT_5.001)

Fan stage (DPT_5.100)

Output value for fan speed

—Parameter“Output value for fan speed low/medium/high”

These three parameters are for setting the value sent for each fan speed switchover. Fan speed off when telegram value is 0. Options according to fan object datatype: **1..255 /1..100**

Status feedback for fan speed

—Parameter“Status value for fan speed low/medium/high”

These three parameters are for setting the status feedback value of each fan speed. The device will update and display the fan speed according to the feedback value. Options according to fan object datatype: **1..255 /1..100**

Note: the output value and status value must meet the condition low<medium<high, if not, they can not be modified on ETS, and display red box warning, as shown as follow:

Output value for Fan speed low	<input type="text" value="33"/>	%
Output value for Fan speed medium	<input type="text" value="32"/>	%
Output value for Fan speed high	<input type="text" value="100"/>	%

Parameter“Fan speed off via manual operation”

This parameter is for setting whether the fan speed off via manual operation.

Disable: The screen cannot switch to or display the fan speed off. When not in auto mode after power-on, receiving a fan speed status value of 0, defaults to switching to low fan speed. When transitioning from power-on to power-off, the fan speed off command is sent.

Enable: The screen can switch to or display the fan speed off.

Parameter“Automatic operation function”

This parameter is for setting the control way of automatic operation. Options:

Disable

Local controller

External controller

When the work mode is "Slave", no option "Local controller", only can select "Disable" or "External controller".

Parameters as follow are visible when select "Local controller":

Fan speed auto control setting

Condition setting for using 2-point control

Under 2-point control, controller will decide the fan power on/off or fan speed according to the temperature difference between the actual temperature and setpoint temperature.

Cooling: Temperature difference = actual temperature - setpoint temperature;

Heating: Temperature difference = setpoint temperature - actual temperature.

Parameter "Temperature difference speed OFF<-->low [0..200]*0.1°C"

This parameter is for setting the temperature difference for speed OFF<-->low.

Options: **0..200, 0=Not allow fan off, minimum operation speed is low**

If the temperature difference is greater than or equal to this setting temperature difference, start to run low fan speed; if less than this setting temperature difference, the fan will be turned off.

Parameter "Temperature difference speed low<-->medium [1..200]*0.1°C"

Define the temperature difference for speed low<-->medium, if the control value is greater than or equal to this setting temperature difference, start to run medium fan speed.

Options: **1..200**

Parameter "Temperature difference speed medium<-->high [1..200]*0.1°C"

Define the temperature difference for speed medium<-->high, if the control value is greater than or equal to this setting temperature difference, start to run high fan speed. Options: **1..200**

Tip: The controller evaluates the temperature difference in ascending order.

First check →OFF <-->low fan speed temperature difference →low fan speed <-->medium fan speed →medium fan speed <-->high fan speed.

If not meet the condition, they can not be modified on ETS, and display red box warning, as shown as follow:

Temperature difference speed OFF<->low [1..200]	<input type="text" value="30"/>	*0.1°C
Temperature difference speed low<->medium [1..200]	<input type="text" value="30"/>	*0.1°C
Temperature difference speed medium<->high [1..200]	<input type="text" value="40"/>	*0.1°C

Parameter "Hysteresis temperature difference in [0..50] *0.1°C"

This parameter is for setting the hysteresis value of the temperature difference, which can avoid the unnecessary action of the fan when the control value fluctuates near the temperature difference.

Options: **0..50**

If value is 0, no hysteresis. Fan switch to speed once control value greater than temperature difference;

Suppose that hysteresis value is 0.5°C and the temperature difference is 1°C, then the upper limit temperature difference 1.5°C (Temperature difference+Hysteresis value) and the lower limit temperature difference 0.5°C (Temperature difference-Hysteresis value). When the control value is between 0.5°C~1.5°C, fan action will not be caused, and the previous status will still be maintained. Only less than 0.5°C or greater than or equal to 1.5°C will change the running status of the fan.

Condition setting for using PI control

Under PI control, control value is PI operated within program, controller will power on/off fan or switch fan speed according to the threshold range of the control values.

Parameter "Threshold value speed OFF<->low [0..255]"

Define threshold value for speed OFF<->low, options: **0..200, 0= Not allow fan off, minimum operation speed is low**

If the control value is greater than or equal to this setting threshold value, start to run low fan speed; if the control value is less than this setting threshold value, the fan will be turned off.

Parameter "Threshold value speed low<->medium [1..255]"

Define the threshold value for speed low<->medium, if the control value is greater than or equal to this setting threshold, start to run medium fan speed. Options: **1..255**

Parameter "Threshold value speed medium<->high [1..255]"

Define the threshold for speed medium<->high, if the control value is greater than or equal to this

setting threshold, start to run high fan speed. Options: 1..255

Tip: The controller evaluates the threshold in ascending order.

First check →OFF ↔low fan speed threshold →low fan speed ↔medium fan speed →medium fan speed ↔high fan speed.

If not meet the condition, they can not be modified on ETS, and display red box warning, as shown as follow:

Threshold value speed OFF↔low [1..255]	<input type="text" value="150"/>
Threshold value speed low↔medium [1..255]	<input type="text" value="150"/>
Threshold value speed medium↔high [1..255]	<input type="text" value="200"/>

The correctness of functional execution is guaranteed only in this case:

The threshold of OFF ↔ low fan speed is lower than that of low fan speed ↔ medium fan speed, and the threshold of low fan speed ↔ medium fan speed is lower than that of medium fan speed ↔ high fan speed.

Parameter Hysteresis threshold value in +/- [0..50]

This parameter is for setting the hysteresis value of the threshold value, which can avoid the unnecessary action of the fan when the control value fluctuates near the threshold. Options: **0..50**

If value is 0, no hysteresis. Fan switch to speed once control value greater than threshold value;

Suppose that hysteresis value is 10 and the threshold is 50, then the upper limit threshold 60 (Threshold value+Hysteresis value) and the lower limit threshold 40 (Threshold value-Hysteresis value). When the control value is between 40 ~60, fan action will not be caused, and the previous status will still be maintained. Only less than 40 or greater than or equal to 60 will change the running status of the fan.

Parameter Minimum time in fan speed [0..65535]s

Defines the residence time of the fan from the current fan speed to a higher fan speed or lower fan speed, that is, the minimum time for a fan speed operation.

If you need to switch to another fan speed, you need to wait for this period of time before switching.

If the current fan speed has been running long enough, the fan speed can be changed quickly.

Options: **0..65535**

0: there is no minimum running time, but the delay switching time of fan speed still needs to be considered.

Note: The residence time for this parameter setting is only enabled in Auto mode.

5.4.1.4. Parameter window "Scene "

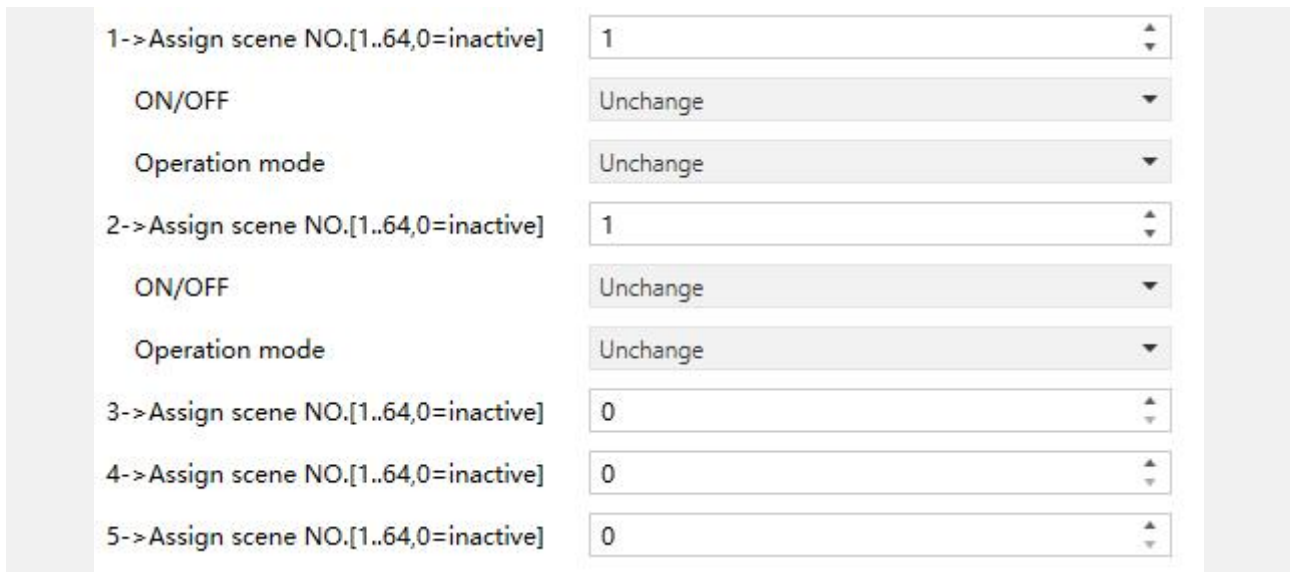

Fig.5.4.1.4 "Scene" Parameter window

When the work mode is "Slave", this parameter window is not visible.

This parameter window is visible when scene function is enabled.

Parameter "x->Assign scene NO.[1..64,0=inactive]" (x=1~5)

This parameter is for setting the triggered scene number. Up to support 5 triggered scenes.

Options: **0..64, 0=inactive**

Scenes can be recalled or stored. When a new scene is stored, the original saved new scene is still valid when the voltage is recovered again after the bus has been powered down.

These three parameters as follow are visible when the option is greater than 0.

Parameter "ON/OFF"

This parameter is for setting status of ON/OFF. Options:

OFF

ON

Unchange

These two parameters as follow are not visible when OFF is selected.

Parameter "Temperature"

This parameter is visible when operation mode is disabled. Set the status of setpoint temperature.

Options:

5°C

6°C

..

37°C

Unchange

When setpoint temperature of scene is less than the min. setpoint temperature, display following warning:

 The setpoint is less than minimum,so minimum will regard as setpoint in fact

When setpoint temperature of scene is greater than the max. setpoint temperature, display following warning:

 The setpoint is greater than maximum,so maximum will regard as setpoint in fact

Parameter "Operation mode"

This parameter is visible when operation mode is enabled. Set the status of operation mode.

Option:

Comfort mode

Standby mode

Economy mode

Frost/heat protection

Unchange

5.4.2. Parameter window“VRF setting”

Indication function icon	<input checked="" type="checkbox"/>
Icon	<input type="text" value="Air conditioner 1"/>
Room temperature reference from	<input type="radio"/> Internal sensor <input checked="" type="radio"/> External sensor
Period for request external sensor [0...255]	<input type="text" value="10"/> min
Interface display temperature	<input type="radio"/> Setpoint temperature <input checked="" type="radio"/> Actual temperature
Object datatype of setpoint	<input type="radio"/> Value in °C(DPT_5.010) <input checked="" type="radio"/> Float value in °C(DPT_9.001)
Setpoint temperature adjustment step	<input type="radio"/> 0.5K <input checked="" type="radio"/> 1K
Min. setpoint temperature [16..32]	<input type="text" value="16"/> °C
Max. setpoint temperature [16..32]	<input type="text" value="32"/> °C
Vanes swing	<input checked="" type="checkbox"/>
Scene	<input checked="" type="checkbox"/>
Send delay between telegrams	<input type="text" value="100ms"/>
Allow to enable lock function via combined button (Button 2&5)	<input checked="" type="checkbox"/>

Fig.5.4.2 “VRF setting” Parameter window

Parameter “Indication function icon”

This parameter is for setting whether to display the icon of VRF control on the screen.

—Parameter “Icon”

This parameter is visible when previous parameter is enabled, set the function icon.

Parameter “Room temperature reference from”

This parameter is for setting the resource of the room temperature reference. Options:

Internal sensor

External sensor

When selecting the reference internal sensor, the temperature is determined by the setting of the “Internal sensor” in the parameter interface, more details refer to [chapter 5.3](#).

—Parameter“Period for request external sensor [0...255]min”

This parameter is visible when “External sensor” is selected. Set the time period for read request external temperature sensor. Options: **0..255**

Parameter“Interface display temperature”

This parameter is for setting the interface display temperature under the normal status. Options:

Setpoint temperature

Actual temperature

If display actual temperature, it just to wake up when firstly adjust setpoint temperature, and not send telegram.

Parameter“Object datatype of setpoint”

This parameter is for setting the object datatype of setpoint temperature. Options:

Value in °C (DPT_5.010)

Float value in °C (DPT_9.001)

Parameter“Setpoint temperature adjustment step”

This parameter is for setting step value of setpoint temperature. Options display according to datatype:

0.5K

1K

When select “Value in °C (DPT_5.010)”, only **1K**

Parameter “Min./Max. setpoint temperature [16..32]°C”

These parameters are for setting the adjustable range of the setpoint temperature, the minimum value should be less than the maximum value. Options:

16°C

17°C

...

32°C

If the setpoint temperature beyond the limited range, the will output the limited temperature.

For setpoint temperature, the Min. value must less than the Max., if not, it can not be modified on

ETS.

Parameter "Vanes swing"

This parameter is for setting whether to enable vanes swing function, when enabled, swing =1 or stop =0 via 1 bit object.

Long press Fan button **1s** to swing/stop the function.

Parameter "Scene"

This parameter is for setting whether to enable scene function is visible. When enabled, link to power on/off, mode, fan speed, setpoint temperature.

—Parameter "Send delay between telegrams"

This parameter is visible when scene function enabled. Set the delay time between the sending telegrams. Options:

Disable

100ms

300ms

500ms

Parameter "Allow to enable lock function via combined button (Button 2&5)"

This parameter is for setting whether to enable lock function via combined button. When enabled, long press button 2 and button 5 simultaneously to lock/unlock the panel. This function does not affect the switch button, all other buttons will be disabled.

The long press time is set by the parameter "long operation for button after [5..250]".

5.4.2.1. Parameter window“Mode”

Auto mode	<input checked="" type="checkbox"/>
Output value for Auto	0
Status value for Auto	0
Heating mode	<input checked="" type="checkbox"/>
Output value for Heating	1
Status value for Heating	1
Cooling mode	<input checked="" type="checkbox"/>
Output value for Cooling	3
Status value for Cooling	3
Fan mode	<input checked="" type="checkbox"/>
Output value for Fan	9
Status value for Fan	9
Dehumidification mode	<input checked="" type="checkbox"/>
Output value for Dehumidification	14
Status value for Dehumidification	14
Sleeping mode	<input checked="" type="checkbox"/>
Output value for Sleeping	14
Status value for Sleeping	14
Refreshing mode	<input checked="" type="checkbox"/>
Output value for Refreshing	14
Status value for Refreshing	14

Fig.5.4.2.1 “Mode” Parameter window

Parameter“Auto/Heating/Cooling/Fan/Dehumidification/Sleeping/Refreshing mode”

Corresponding setting parameters are visible when these parameters are enabled.

— — Parameter“Output value for auto/heating/cooling/fan/dehumidification/sleeping/refreshing [0..255]”

These parameters are visible when modes enabled. Set the output value of each mode.

Options: **0..255**

— — Parameter“Status value for auto/heating/cooling/fan/dehumidification/sleeping/refreshing [0..255]”

These parameters are visible when modes enabled. Set the status feedback value of each mode.

Options: 0..255

5.4.2.2. Parameter window“Fan”

Fan speed auto function	<input checked="" type="checkbox"/>
Fan speed level	<input checked="" type="radio"/> 3 <input type="radio"/> 5
Object datatype of 1byte fan speed	<input checked="" type="radio"/> Percentage (DPT_5.001) <input type="radio"/> Fan stage (DPT_5.100)
Output value for Fan speed	
Output value for Fan speed auto	<input type="text" value="0"/> %
Output value for Fan speed 1	<input type="text" value="33"/> %
Output value for Fan speed 2	<input type="text" value="67"/> %
Output value for Fan speed 3	<input type="text" value="100"/> %
Status feedback for Fan speed	
Status value for Fan speed auto	<input type="text" value="0"/> %
Status value for Fan speed 1	<input type="text" value="33"/> %
Status value for Fan speed 2	<input type="text" value="67"/> %
Status value for Fan speed 3	<input type="text" value="100"/> %

Fig.5.4.2.2 “Fan” Parameter window

Parameter“Fan speed auto function”

This parameter is for setting whether to enable fan speed auto function.

Enable: Fan speed button cycles through 1~3/5 → Auto

Disable: Fan speed button cycles through 1~3/5

Parameter“Fan speed level”

This parameter is for setting the number of fan speed levels. Options:

3

5

When 3 fan speed levels, only support to auto/1/2/3;

When 5 fan speed levels, support to auto/1/2/3/4/5.

Parameter "Object datatype of 1byte fan speed"

This parameter is for setting the object datatype of 1 byte fan speed. Options:

Fan stage (DPT 5.100)

Percentage (DPT 5.001)

Output value for fan speed

——Parameter "Output value for fan speed auto/1/2/3/4/5"

These parameters are for setting the value sent for each fan speed switchover, displayed according to the configured number of fan speed levels.

Options according to fan object datatype: **0..255/0..100**

Status feedback for fan speed

——Parameter "Status value for fan speed auto/1/2/3/4/5"

These parameters are for setting the status feedback value for each fan speed, displayed according to the configured number of fan speed levels. Device updates the screen display according to feedback values.

Options according to fan object datatype: **0..255/0..100**

5.4.2.3. Parameter window“Scene ”

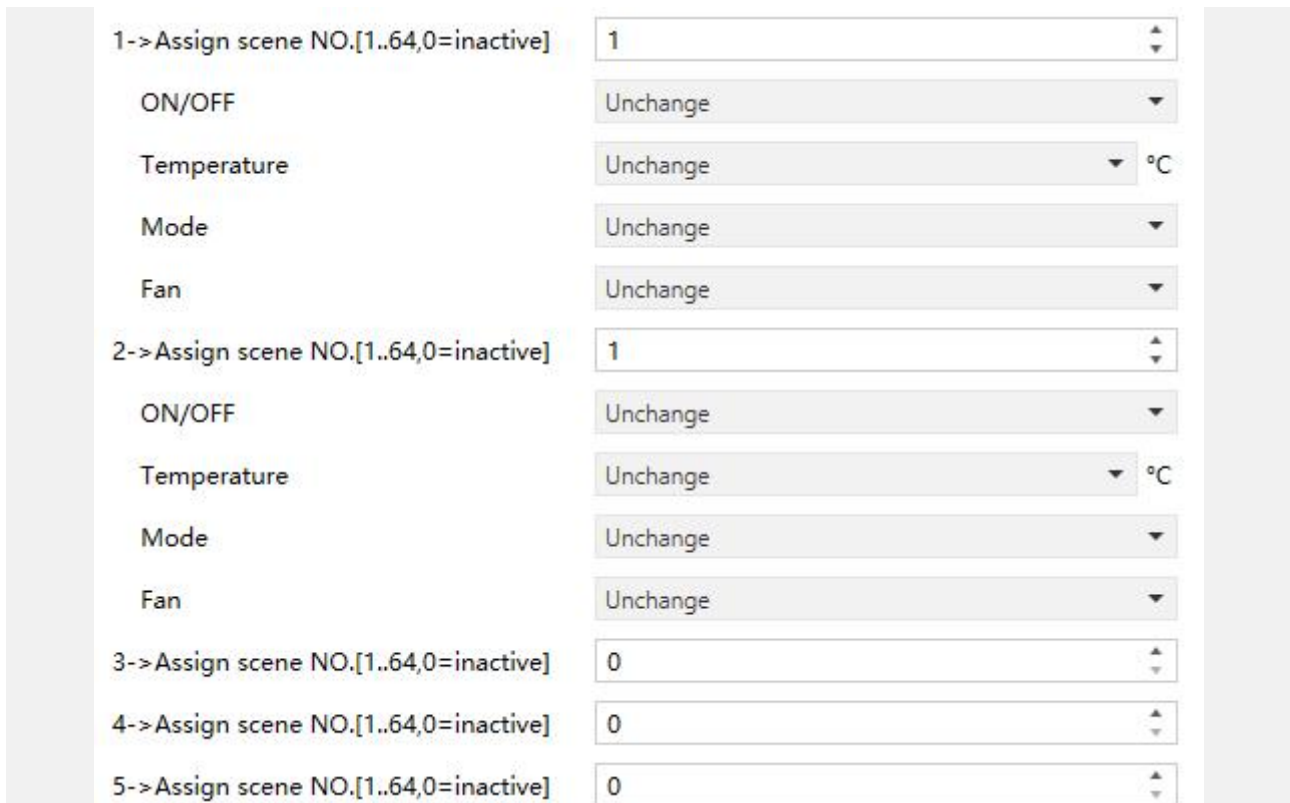

Fig.5.4.2.3 “Scene” Parameter window

This parameter window is visible when scene function is enabled.

Parameter “x->Assign scene NO.[1..64,0=inactive]” (x=1~5)

This parameter is for setting the triggered scene number. Up to support 5 triggered scenes.

Options: **0..64, 0=inactive**

These four parameters as follow are visible when the option is greater than 0.

Parameter “ON/OFF”

This parameter is for setting status of ON/OFF. Options:

OFF

ON

Unchange

These three parameters as follow are not visible when OFF is selected:

Parameter “Temperature”

This parameter is for setting the status of setpoint temperature. Options:

16°C

17°C

..

32°C

Unchange

When setpoint temperature of scene is less than the min. setpoint temperature, display following warning:

✘ The setpoint is less than minimum,so minimum will regard as setpoint in fact

When setpoint temperature of scene is greater than the max. setpoint temperature, display following warning:

✘ The setpoint is greater than maximum,so maximum will regard as setpoint in fact

Parameter "Mode"

This parameter is for setting the status of mode. Options:

Auto

Heating

Cooling

Fan

Dehumidification

Sleeping

Refreshing

Unchange

Parameter "Fan"

This parameter is for setting the status of fan speed.

Options: **Auto/Speed 1/Speed 2/Speed 3/unchange**

Note: ON/OFF, temperature, mode and fan speed send in order. If not finish during delay time and have a new command, perform the new one. Unperformed operations are ignored.

5.4.3. Parameter window "Floor heating setting"

Indication function icon	<input checked="" type="checkbox"/>
Icon	 Water heating
Work mode	Master
Room temperature reference from	Internal and External sensor combination
Combination ratio	50% Internal to 50% External
Period for request external sensor [0..255]	5 min
Send temperature when the result change by	1.0K
Cyclically send temperature [0...255,0=inactive]	0 min
Control value after temp. error [0..100] (If 2-point control, set value '0'=0, set value '>0'=1)	0 %
Interface display temperature	<input type="radio"/> Setpoint temperature <input checked="" type="radio"/> Actual temperature
Setpoint temperature adjustment step	<input checked="" type="radio"/> 0.5K <input type="radio"/> 1K
Default setpoint temperature [16..32]	20 °C
Min. setpoint temperature [16..32]	16 °C
Max. setpoint temperature [16..32]	32 °C
Power on/off function	Via both button and object
Power on/off status after download	<input type="radio"/> OFF <input checked="" type="radio"/> ON
Power on/off status after voltage recovery	As before voltage failure
Temperature control method	Heating on/off (2 point control)
Object value of Heating on/off	<input checked="" type="radio"/> Heat on=1, Heat off=0 <input type="radio"/> Heat on=0, Heat off=1
Lower Hysteresis [0..200]	10 *0.1K
Upper Hysteresis [0..200]	10 *0.1K



Fig.5.4.3 "Floor heating setting" Parameter window

Parameter "Indication function icon"

This parameter is for setting whether to display the icon of floor heating function on the screen.

—Parameter "Icon"

This parameter is visible when previous parameter is enabled, set the function icon.

Parameter "Work mode"

This parameter is for setting the work mode of floor heating. Options:

Single

Master

Slave

Single: the device is a single control in the system and has a temperature control algorithm, the output directly controls the actuator;

Master: the device belongs to multi-control in the system, and the floor heating output is dominated by the device, and has temperature control algorithm. When the device restarts, it sends the current status to the bus, such as power on/off, setpoint temperature;

Slave: the device belongs to the slave control in the system, at this time floor heating is only used as touch and display, no temperature control algorithm, when the device restarts, it will send the status read request, such as power on/off, setpoint temperature.

Parameter "Room temperature reference from"

This parameter is for setting the resource of the room temperature reference. Options:

Internal sensor

External sensor

Internal and External sensor combination

When selecting the reference internal sensor, the temperature is determined by the setting of the "Internal sensor" in the parameter interface, more details refer to [chapter 5.3](#).

—Parameter“Period for request external sensor [0...255]min”

This parameter is visible when “External sensor” or “Internal and External sensor combine” is selected. Set the time period for read request external temperature sensor. Options: **0..255**

Parameters as follow are visible when “Internal sensor combine with External sensor” is selected:

—Parameter“Combination ratio”

This parameter is for setting the internal sensor and the external sensor to measure the specific gravity of the temperature. Options:

10% Internal to 90% External

20% Internal to 80% External

...

90% Internal to 10% External

For example, if the option is “40% internal to 60% external”, then the internal sensor accounts for 40%, the external sensor accounts for 60%, and the control temperature = (internal sensor's temperature × 40%) + (external sensor's temperature × 60%), the RTC function of the device will control and display the temperature according to the calculated temperature.

When two sensors are combined for detection, when one sensor is in error, the temperature value detected by the other sensor is used.

—Parameter“Send temperature when the result change by”

This parameter is for setting when temperature turns to a certain value, whether to enable to send the current temperature value to the bus. No telegram is sent when Disable is selected. Options:

Disable

0.5K

1.0K

...

10.0K

—Parameter“Cyclically send temperature [0...255]min”

Setting the time for cyclically sending the temperature detection value to the bus. No telegram is sent when value is 0. Options: **0..255**

Note: cyclically sending and change sending are independent of each other.

Parameter "Control value after temp. error[0..100]% (if 2-point control, set value '0'=0, set value '>0'=1)"

When the work mode is "Slave", this parameter is not visible. Set the control value when temperature error occur. Options: **0..100**

If 2-Point control, then the parameter value is 0, as well as the control value; if the parameter value is more than 0, then the control value will be 1.

Parameter "Interface display temperature"

This parameter is for setting the interface display temperature under the normal status. Options:

Setpoint temperature

Actual temperature

If display actual temperature, it just to wake up when firstly adjust setpoint temperature, and not send telegram.

Parameter "Setpoint temperature adjustment step"

This parameter is for setting step value of setpoint temperature. Options:

0.5K

1K

Parameter "Default setpoint temperature [16..32]°C"

When the work mode is "Slave", this parameter is not visible. Set the default temperature when floor heating is on. Options:

16°C

17°C

...

32°C

Note: When the default setpoint temperature is lower than the setpoint temperature or higher than the setpoint temperature, it can not be modified on ETS.

Parameter "Min./Max. setpoint temperature [16..32]°C"

These parameters are for setting the adjustable range of the setpoint temperature, the minimum

value should be less than the maximum value.

If the setpoint temperature beyond the limited range, it will output the limited temperature. Options:

16°C

17°C

...

32°C

For setpoint temperature, the Min. value must less than the Max., if not, it can not be modified on ETS.

Parameter "Power on/off function "

This parameter is for setting whether to enable power on/off function of controller. Options:

Disable

Via button only

Via object only

Via both button and object

Parameter "Power on/off status after download "

When the work mode is "Slave", this parameter is not visible. Set the power on/off status of floor heating interface after download. Options:

OFF

ON

Parameter "Power on/off status after power on "

When the work mode is "Slave", this parameter is not visible. Set the power on/off status of floor heating interface after device voltage recovery. Options:

OFF

ON

As before voltage failure

OFF: floor heating interface is off when device is powered on, other icons in the interface are not operational except for timing and on/off icon.

ON: floor heating interface is on when device is powered on, this interface is operational, floor

heating will calculate internally according to the control type to determine the current controlling status.

As before voltage failure: floor heating interface will recover to the status before voltage failure, if it is on, then the device will send the heating control status according to the internal calculation.

Parameter "Temperature control method"

When the work mode is "Slave", this parameter is not visible. Set the temperature control method, different control types are suitable for different temperature controller. Options:

Heating on/off (2 point control)

Heating PWM (use PI control)

Heating continuous control (use PI control)

These parameters as follow are visible when "Heating on/off (use 2-point control)" is selected:

Under 2-point control, when the temperature is higher than a certain setpoint temperature, heating off, below a certain setpoint temperature, heating on.

—Parameter "Object value of Heating on/off"

Define the triggered value of floor heating on/off. Options:

Heat on=1, Heat off=0

Heat on=0, Heat off=1

—Parameter "Lower Hysteresis [0..200]*0.1K"

—Parameter "Upper Hysteresis [0..200]*0.1K"

These two parameters for setting the lower/upper hysteresis setpoint temperature of floor heating.

Options: **0..200**

When the actual temperature(T) > the setting temperature + the upper hysteresis temperature, then will stop heating;

When the actual temperature(T) < the setting temperature - the lower hysteresis temperature, then will start heating.

For example, the lower hysteresis temperature is 1K, the upper hysteresis temperature is 2K, the setting temperature is 16°C, if T is higher than 18°C, then it will stop heating; if T is lower than 15°C, then it will start heating; if T is between 15~18°C, then it will maintain the previous status.

These parameters as follow are visible when “Heating PWM (use PI control)” or “Heating continuous control (use PI control)” is selected:

When in Heating PWM (use PI control), floor heating will in cyclically switch control to the valve according to the controlling value.

When in Heating continuous control (use PI control), floor heating will control the opening/closing status of the valve according to the controlling value.

—Parameter “Invert control value”

This parameter is for setting whether to invert control value or normal sending control value, so that the control value will be suitable for the valve type.

When enabled, send the control value to the bus through objects after inverting the control value.

—Parameter “PWM cycle time [1..255] min”

This parameter is visible only when the control type is “Heating PWM (use PI control)” and is used to set the cycle of the control object cycle to send the switch value, and the object sends the switch value according to the duty cycle of the control value. For example, assuming the set period is 10 min and the control value is 80%, the object sends an open telegram to the 8min and the 2min sends a closed telegram. If the control value changes, The duty cycle of the object to send the on/off telegram also changes, but the period is still the time of the parameter setting. Options: **1..255**

—Parameter “Heating speed”

This parameter is Setting for the response speed of the heating PI controller. Different response speeds apply to different environments. Options:

Hot water heating (5K/150min)

Underfloor heating (5K/240 min)

Electrical heating (4K/100min)

User defined

—Parameter “Proportional range [10..100]*0.1K”(P value)

—Parameter “Reset time[0..255]min”(I value)

These two parameters are visible when “User defined” is selected. Set the PI value of PI controller.

Options: **10..100 (P value)**

Options: **0..255 (I value)**

—Parameter“Send control value on change by [0..100,0=inactive]%

This parameter is visible when “Continuous control (use PI control)” is selected. Set the changing value of the control value to be sent to the bus. Options: **0..100, 0=inactive**

More descriptions of two-point control mode and PI control mode refer to chapter 5.4.1.

Parameter“Cyclically send control value [0..255]min”

This parameter is for setting the period for cyclically sending the control value to the bus.

Options: **0..255**

Parameter“Scene”

When the work mode is “Slave”, this parameter is not visible. Set whether to enable scene function is visible. When enabled, link to power on/off, setpoint temperature.

Parameter“Allow to enable lock function via combined button (Button 2&5)”

This parameter is for setting whether to enable lock function via combined button. When enabled, long press button 2 and button 5 simultaneously to lock/unlock the panel. This function does not affect the switch button, all other buttons will be disabled.

The long press time is set by the parameter “long operation for button after [5..250]”.

5.4.3.1. Parameter window "Scene "

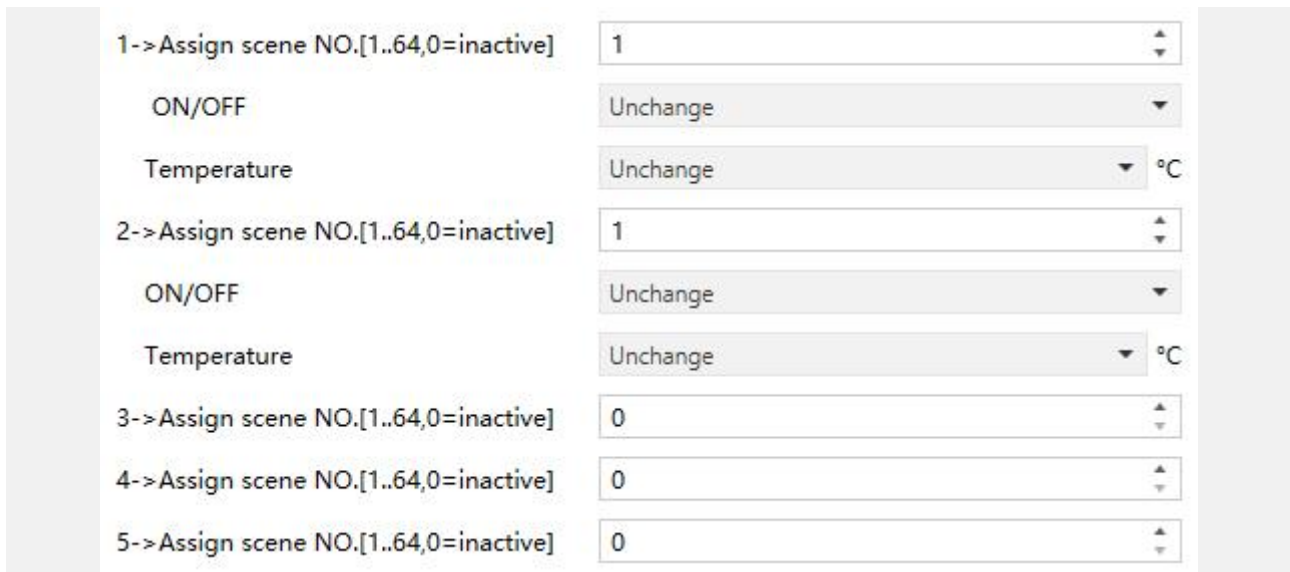

Fig.5.4.3.1 "Scene" Parameter window

When the work mode is "Slave", this parameter window is not visible.

This parameter window is visible when scene function is enabled.

Parameter "x->Assign scene NO.[1..64,0=inactive]" (x=1~5)

This parameter is for setting the triggered scene number. Up to support 5 triggered scenes.

Options: **0..64, 0=inactive**

Scenes can be recalled or stored. When a new scene is stored, the original saved new scene is still valid when the voltage is recovered again after the bus has been powered down.

These two parameters as follow are visible when the option is greater than 0.

Parameter "ON/OFF"

This parameter is for setting status of ON/OFF. Options:

OFF

ON

Unchange

This parameter as follow is not visible when OFF is selected.

Parameter "Temperature"

This parameter is for setting the status of setpoint temperature. Options:

16°C

17°C

...

32°C

Unchange

When setpoint temperature of scene is less than the min. setpoint temperature, display following warning:

 The setpoint is less than minimum,so minimum will regard as setpoint in fact

When setpoint temperature of scene is greater than the max. setpoint temperature, display following warning:

 The setpoint is greater than maximum,so maximum will regard as setpoint in fact

5.4.4. Parameter window“Ventilation setting”

Indication function icon	<input checked="" type="checkbox"/>
Icon	 Ventilation system
<hr/>	
Fan speed level	<input checked="" type="radio"/> 3 <input type="radio"/> 5
Power on/off status after download	<input checked="" type="radio"/> OFF <input type="radio"/> ON
Power on/off status after voltage recovery	As before voltage failure
Default fan speed after ventilation on	Speed 1
Object datatype of 1byte fan speed	<input checked="" type="radio"/> Percentage (DPT_5.001) <input type="radio"/> Fan stage (DPT_5.100)
Output value for Fan speed	
Output value for Fan speed 1	33 %
Output value for Fan speed 2	67 %
Output value for Fan speed 3	100 %
Status feedback for Fan speed	
Status value for Fan speed 1	33 %
Status value for Fan speed 2	67 %
Status value for Fan speed 3	100 %
<hr/>	
Automatic operation function	<input checked="" type="checkbox"/>
Heat Recovery function	<input checked="" type="checkbox"/>
Filter timer counter	<input checked="" type="checkbox"/>
Evaluation time [100..10000]	1000 h
Mode	<input checked="" type="checkbox"/>
Scene	<input checked="" type="checkbox"/>
Allow to enable lock function via combined button (Button 2&5)	<input checked="" type="checkbox"/>

Fig.5.4.4 “Ventilation setting” Parameter window

Parameter “Indication function icon”

This parameter is for setting whether to display the icon of ventilation function on the screen.

—Parameter “Icon”

This parameter is visible when previous parameter is enabled, set the function icon.

Parameter "Fan speed level"

This parameter is for setting the fan speed level. Options:

3

5

When 3 fan speed levels, only support to 1/2/3.

When 5 fan speed levels, support to 1/2/3/4/5.

Parameter "Power on/off status after download "

This parameter is for setting the power on/off status of the ventilation system interface after the application is downloaded. Options:

OFF

ON

Parameter "Power on/off status after voltage recovery"

This parameter is for setting the power on/off status of ventilation system interface after device voltage recovery. Options:

OFF

ON

As before voltage failure

OFF: Device will power off when voltage recovery, this interface can not be operated, except for filter reset and power ON/OFF.

ON: Device will power on when voltage recovery, this interface can be operated.

As before voltage failure: Device will return to the power status as before voltage failure when voltage recovery.

Parameter "Default fan speed after ventilation on"

This parameter is for setting the initial fan speed after ventilation on. Options:

Speed 1

Speed 2

Speed 3

Last status

When "Last status" is selected, if not sure the fan speed, enable the low fan speed as default.

Parameter "Object datatype of 1byte fan speed"

This parameter is for setting the object datatype of 1 byte fan speed. Options:

Fan stage (DPT 5.100)

Percentage (DPT 5.001)

Output value for fan speed

—Parameter "Output value for fan speed 1/2/3/4/5"

These three parameters are for setting the value sent for each fan speed switchover. Fan speed off when telegram value is 0. Options according to fan object datatype: **1..255 / 1..100**

Status feedback for fan speed

—Parameter "Status value for fan speed 1/2/3/4/5"

These three parameters are for setting the status feedback value of each fan speed. The device will update and display the fan speed according to the feedback value.

Options according to fan object datatype: **1..255 / 1..100**

Parameter "Automatic operation function"

This parameter is for setting whether to enable fan speed auto function. When enabled, it can be linked with PM2.5 or CO2 and VOC detection value, the sensor data is achieved from the bus.

Telegram 1 is to active the auto fan speed, 0 is cancel.

Parameter "Heat recovery function"

This parameter is for setting whether to enable heat recovery function, display corresponding object when enable.

Parameter "Filter timer counter"

This parameter is for setting whether to enable the function of filter timer counter.

—Parameter "Evaluation time [100..10000]h"

This parameter is visible when previous parameter is enabled.

Set the service life of the filter. Options: **100..10000**

If the filter takes longer than the setting time, the filter will send an alarm and prompt to clean the

filter.

The life length of the filter can be reset through the object "Filter timer reset", long press Fan button **3s** also can reset the life length. And send the reset telegram to the bus.

The life length of the filter can be counted by the object "Filter timer counter". The counting duration is in hours. The counting value will be sent to the bus when it has changed, and the counting duration of filter can be modified by the object "Filter timer counter change".

Parameter "Scene"

This parameter is for setting whether to enable scene function is visible. When enabled, link to fan speed and heat recovery.

Parameter "Allow to enable lock function via combined button (Button 2&5)"

This parameter is for setting whether to enable lock function via combined button. When enabled, long press button 2 and button 5 simultaneously, long press time = parameter "long operation for button after [5..250]" = lock/unlock. This function does not affect the switch button, all other buttons will be disabled.

5.4.4.1. Parameter window“Fan auto.control”

Control value reference from	CO2
Object datatype of CO2	<input type="radio"/> Value in ppm(DPT_7.001) <input checked="" type="radio"/> Float value in ppm(DPT_9.008)
Period for request control value [0..255]	10 min
The speed status after control value error	OFF
Threshold value OFF<->speed 1 [1..4000]	450
Threshold value speed 1<->2 [1..4000]	1000
Threshold value speed 2<->3 [1..4000]	2000
Hysteresis value is threshold value in +/- [100..400]	200
Minimum time in fan speed [0..65535]	10 s

Fig.5.4.4.1 “Fan auto.control” Parameter window

This parameter window is visible when automatic operation function is enabled.

Parameter“Control value reference from”

This parameter is for setting the reference of control value under automatic operation. Options:

CO2

PM2.5

VOC

Parameter“Object datatype of CO2”

This parameter is for setting the datatype of CO2. Datatype determines object type, select it according to the docking CO2 sensor data type. Options:

Value in ppm(DPT_7.001)

Float value in ppm(DPT_9.008)

DPT_7.001: Suitable for integrated value.

DPT_9.008: Suitable for float value.

Parameter“Object datatype of PM2.5/VOC”

These two parameters are for setting the datatype of PM2.5/VOC. Datatype determines object type, select it according to the docking PM2.5 or VOC sensor data type. Options:

Value in ug/m3(DPT_7.001)

Float value in ug/m3(DPT_9.030)

DPT_7.001: Suitable for integrated value.

DPT_9.030: Suitable for float value.

Parameter "Period for request control value [0...255]min"

This parameter is for setting the time period for device to send a control value read request to external sensor after bus recovery or finish programming (**After stabilization time 2min, then read**).

Options: **0..255**

Parameter "The fan speed status after control value error"

This parameter is for setting the fan speed status after control value error. Options:

OFF

Speed 1

Speed 2

Speed 3

Speed 4

Speed 5

Parameter "Threshold value speed OFF<-->speed 1 [1..999]/ [1...4000]"

Define threshold value for speed OFF<-->speed 1, options: **1..999/1..4000**

If the control value is greater than or equal to this setting threshold value, start to run low fan speed; if the control value is less than this setting threshold value, the fan will be turned off.

Parameter "Threshold value speed 1<-->2 [1..999]/ [1...4000]"

Define the threshold value for speed 1<-->speed 2, if the control value is greater than or equal to this setting threshold, start to run speed 2. Options: **1..999/1..4000**

Parameter "Threshold value speed 2<-->3 [1..999]/ [1...4000]"

Define the threshold for speed 2<-->speed 3, if the control value is greater than or equal to this setting threshold, start to run speed 3. Options: **1..999/1..4000**

Tip: The controller evaluates the threshold in ascending order.

First check →OFF <-->fan speed 1 threshold →fan speed 1<-->fan speed 2→fan speed 2<-->fan speed 3.

If not meet the condition, they can not be modified on ETS, and display red box warning, as shown

as follow:

Threshold value OFF<->speed 1 [1..999]	80
Threshold value speed 1<->2 [1..999]	75
Threshold value speed 2<->3 [1..999]	115

The correctness of functional execution is guaranteed only in this case:

The threshold of OFF <-> fan speed 1 is lower than that of fan speed 1<-> fan speed 2, and the threshold of fan speed 1<-> fan speed 2 is lower than that of fan speed 2<-> fan speed 3.

Parameter "Hysteresis threshold value in +/- [10..30]/[100..400]"

This parameter is for setting the hysteresis value of the threshold value, which can avoid the unnecessary action of the fan when the control value fluctuates near the threshold. Options:

10..30/100..400

For example, the control type is CO2, the Hysteresis value is 100 and the threshold is 450, then the upper limit threshold 550 (Threshold value+Hysteresis value) and the lower limit threshold 350 (Threshold value-Hysteresis value). When the control value is between 350 ~550, fan action will not be caused, and the previous status will still be maintained. Only less than 350 or greater than or equal to 550 will change the running status of the fan. As shown in the following figure:

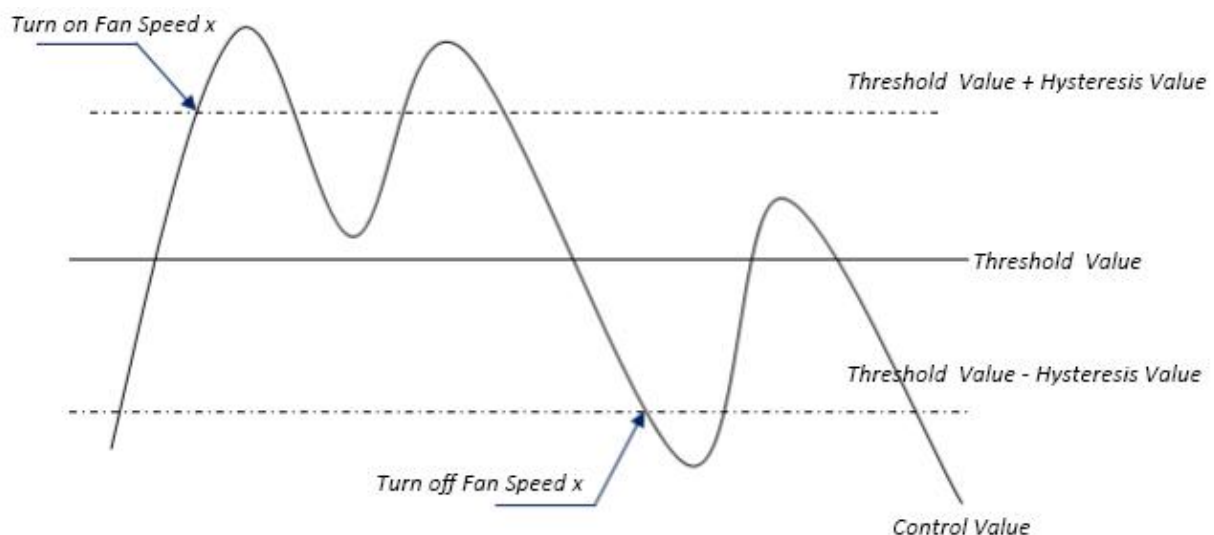

Note:

When hysteresis is enabled, if the threshold overlap occurs, fan action is specified as follows:

1) Hysteresis determines the control point where Fan speed conversion occurs;

2) If Fan speed conversion occurs, new fan speed is determined by control value and threshold value, irrespective of hysteresis.

For example (1):

Take PM2.5 as an example

OFF <-> fan speed 1 threshold value is 35

fan speed 1 <-> fan speed 2 threshold value is 55

fan speed 2 <-> fan speed threshold 3 value is 75

Hysteresis value is 25

The fan speed of the fan turbine increases from OFF:

Fan OFF status will change at a control value of 60 ($\geq 25+35$), and new fan speed will be the fan speed 2 (because 60 is between 55 and 75, irrespective of hysteresis at this time), so the fan speed 1 is ignored;

The behavior of fan speed when descending from a fan speed 3:

The fan speed 3 will change at a control value of 50 ($< 75-25$), and new fan speed will be fan speed 1 (because 50 is between 35 and 55, irrespective of hysteresis), so the fan speed is ignored.

For example(2):

Take PM2.5 as an example

OFF <-> fan speed 1 threshold value is 20

fan speed 1 <-> fan speed 2 threshold value is 40

fan speed 2 <-> fan speed 3 threshold value is 70

Hysteresis value is 10

When fan speed is increasing from OFF:

The OFF status will be turned when the control value is 30 ($\geq 20+10$)

When the control value 41 is received, the new speed will be at 2 (because the hysteresis is ignored when the value 41 is between 40 and 70), therefore the fan speed 1 is ignored.

When the control value 39 is received, the new speed will be at 1 (because the hysteresis is ignored when the value 39 is between 20 and 40)

When Fan Speed decreasing from 3:

The fan speed 3 will be turned when the control value is 60 (<70-10)

When the control value 39 is received, the new speed will be at 1(because the hysteresis is ignored when the value 39 is between 20 and 40),therefore the fan speed 2 is ignored.

3) When the control value is 0,the fan will be off at any circumstances.

Parameter Minimum time in fan speed [0..65535]s'

Defines the residence time of the fan from the current fan speed to a higher fan speed or lower fan speed, that is, the minimum time for a fan speed operation. Options: **0..65535**

If you need to switch to another fan speed, you need to wait for this period of time before switching.

If the current fan speed has been running long enough, the fan speed can be changed quickly.

0: there is no minimum running time, but the delay switching time of fan speed still needs to be considered.

Note: The residence time for this parameter setting is only enabled in Auto mode.

5.4.4.2. Parameter window“Mode”

Customized mode 1	<input checked="" type="checkbox"/>
Description for customized mode 1	Heat
Output value for customized mode 1	1
Status value for customized mode 1	1
Customized mode 2	<input checked="" type="checkbox"/>
Description for customized mode 2	Bypass
Output value for customized mode 2	2
Status value for customized mode 2	2
Customized mode 3	<input checked="" type="checkbox"/>
Description for customized mode 3	Auto
Output value for customized mode 3	3
Status value for customized mode 3	3
Customized mode 4	<input checked="" type="checkbox"/>
Description for customized mode 4	Air
Output value for customized mode 4	4
Status value for customized mode 4	4
Customized mode 5	<input checked="" type="checkbox"/>
Description for customized mode 5	Exhaust
Output value for customized mode 5	5
Status value for customized mode 5	5

Fig.5.4.4.2 “Mode” Parameter window

Parameter “Customized mode x”(x=1~10)

This parameter is for setting whether to enable customized mode x.

These parameters as follow are visible when “Customized mode x” is enabled:

——Parameter “Description for customized mode x”(x=1~10)

This parameter is for setting the description for customized mode x.

Note: If the description exceeds the display area, text will scroll left by single characters.

——Parameter “Output value for customized mode x”(x=1~10)

This parameter is for setting the output value for customized mode x.

— Parameter "Status value for customized mode x" (x=1~10)

This parameter is for setting the status value for customized mode x.

5.4.4.3. Parameter window "Scene "

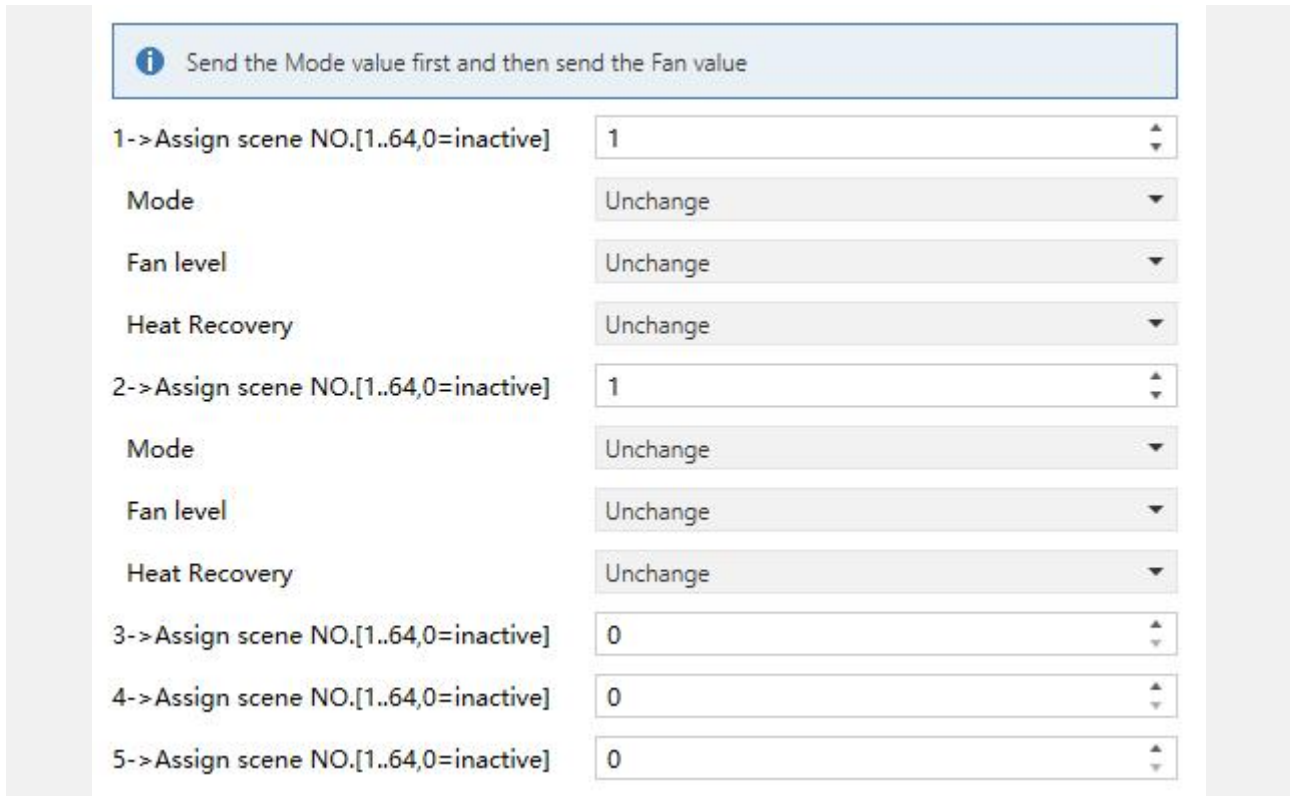

Fig.5.4.4.3 "Scene" Parameter window

This parameter window is visible when scene function is enabled.



Parameter "x->Assign scene NO.[1..64,0=inactive]" (x=1~5)

This parameter is for setting the triggered scene number. Up to support 5 triggered scenes.

Options: **0..64, 0=inactive**

These two parameters as follow are visible when the option is greater than 0.

— Parameter "Mode"

This parameter is for setting the mode for scene X. Options:

Disable

Customized mode 1

...

Customized mode 10

Unchange

—— Parameter "Fan"

This parameter is for setting status of fan speed. Options:

OFF

Speed 1

Speed 2

Speed 3

Unchange

This parameter as follow is not visible when OFF is selected.

—— Parameter "Heat recovery"

This parameter is visible when heat recovery function is enabled. Setting status of heat recovery.

Options:

OFF

ON

Unchange

5.4.5. Parameter window“Audio”

Power on/off	<input checked="" type="checkbox"/>
Power on/off status after download	<input checked="" type="radio"/> OFF <input type="radio"/> ON
Power on/off status after voltage recovery	Before voltage failure ▼
<hr/>	
Number of object for play/pause control	<input checked="" type="radio"/> 1 <input type="radio"/> 2
Number of object for next/previous track control	<input checked="" type="radio"/> 1 <input type="radio"/> 2
Volume adjustment via short operation	Increase/Decrease
Volume adjustment via long operation	Relative control ▼
Work mode	<input checked="" type="radio"/> Start-stop <input type="radio"/> Step adjustment
Step size	100 %
Interval of tele. cyclic send [0..25,0=send once]	0 *0.1s
Mute	<input checked="" type="checkbox"/>
<hr/>	
Track name	<input checked="" type="checkbox"/>
Artist name	<input checked="" type="checkbox"/>
Album name	<input checked="" type="checkbox"/>
<hr/>	
Play mode	<input checked="" type="checkbox"/>
Play for single cycle	<input checked="" type="checkbox"/>
Output value	0 ▲▼
Status value	0 ▲▼
Play for random	<input checked="" type="checkbox"/>
Output value	1 ▲▼
Status value	1 ▲▼
Play for playlist cycle	<input checked="" type="checkbox"/>
Output value	2 ▲▼
Status value	2 ▲▼

Fig.5.4.5 “Audio” Parameter window

Parameter "Power on/off"

This parameter is for setting whether to activate the function to power on/off.

If power on/off is enabled, you can set the initial status after voltage recovery or download.

If power on/off is disabled, the audio interface is always on.

Icon of power on/off on the screen is not visible when disabled. These two parameters as follow are visible when enabled:

Parameter "Power on/off status after download"

This parameter is for setting the power on/off status of audio control interface after download.

Options:

OFF

ON

Parameter "Power on/off status after voltage recovery"

This parameter is for setting the power on/off status of audio control interface after device voltage recovery. Options:

OFF

ON

Before voltage failure

On: device will power on when voltage recovery, this interface can be operated.

Off: device will power off when voltage recovery, this interface can not be operated.

Before voltage failure: device will return to the power status as before voltage failure when voltage recovery.

Parameter "Number of object for play/pause control"

This parameter is for setting the number of objects that control play/pause, 1 common object or 2 separate objects. Options:

1

2

Parameter "Number of object for next/previous track control"

This parameter is for setting the number of objects that control next/previous track, 1 common object or 2 separate objects. Options:

1

2

Parameter "Volume adjustment via short operation"

This parameter is for setting control type of volume adjustment via short operation.

Option is only **Increase/Decrease**

Parameter "Volume adjustment via long operation"

This parameter is for setting control type of volume adjustment via long operation. Options:

Disable

Relative control

Absolute control

Disable: no long operation when disabled.

Relative control: long operation and release to send 4bit and stop telegrams.

Absolute control: long operation to send absolute volume telegrams, and no telegram to send when release.

Short press to send 1bit telegram.

No matter relative or absolute control, the volume displaying on the screen is only related to the telegrams from bus, it can not be updated by long operation, as well as short operation.

These parameters as follow are visible when "Relative control" is selected:

—Parameter "Work mode"

This parameter is for setting work mode of relative control. Options:

Start-stop

Step adjustment

Start-stop: The default step size is 100% and adjusts immediately.

Step adjustment: Adjust according to the parameter "Step size" .

—Parameter“Step size”

This parameter is for setting the step size of relative adjustment.

When “Start-stop” is selected, option is only **100%**

When “Step adjustment” is selected, options:

100%

50%

...

3.13%

1.56%

E.g. step size is 50%, telegram value is: increase is 10 and decrease is 2, similar to relative dimming telegrams.

These three parameter as follow are visible when “Absolute control” is selected:

—Parameter“Object datatype”

This parameter is for setting the object datatype of absolute adjustment. Options:

Percentage (DPT_5.001)

Percentage (DPT_5.004)

—Parameter“Step size [1..10]”

This parameter is for setting the step size of absolute adjustment. Options: **1..10**

E.g. current volume is 10%, the step size is 5%, then after adjusting once, the output volume will be 15%.

—Parameter“Max. volume value [10..100]”

This parameter is for setting the maximum volume value. Options: **10..100**

—Parameter“Interval of tele. cyclic send [0..25,0=send once]”

This parameter is visible when “Disable” is not selected. Set the time interval of cyclical volume adjustment telegram sent via long operation. Options: **0..25,0=send once**

The time interval is default as **0** when relative control and “Start-stop” is selected.

Parameter "Mute"

This parameter is for setting whether to enable mute function.

Parameter "Track name"

This parameter is for setting whether to display the track name.

Parameter "Artist name"

This parameter is for setting whether to display the artist name.

Parameter "Album name"

This parameter is for setting whether to display the album name.

Parameter "Play mode"

This parameter is for setting whether to enable play mode, display the parameters as follow when enabled.

Parameter "Play for single cycle"

Parameter "Play for random"

Parameter "Play for playlist cycle"

These parameter are for setting whether to enable play in single cycle/play for random/play for playlist cycle mode. Display two parameters as follow when enable.

—Parameter "Output value"

This parameter is for setting the output value of each play mode. Options: **0..255**

—Parameter "Status value"

This parameter is for setting the status value of each play mode. Device will be updated the play mode displayed on the screen according to the feedback value. Options: **0..255**

5.4.6. Parameter window "Customized colour"

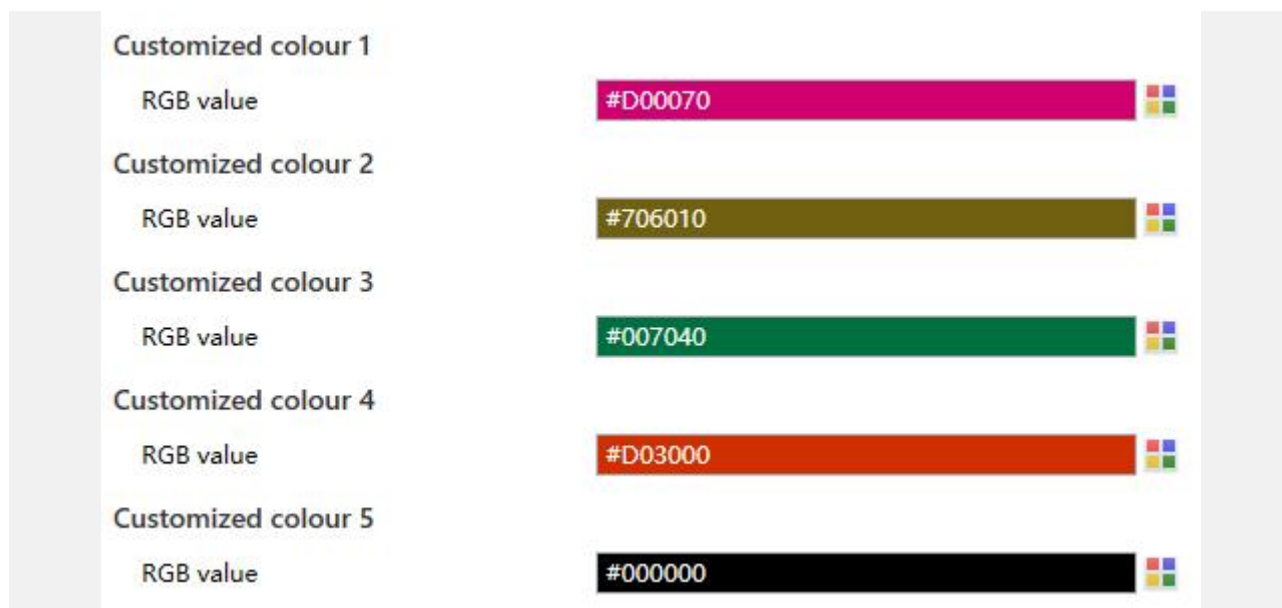

Fig.5.4.6 "Customized colour" Parameter window

Customized colour x(x=1~5)

Parameter "RGB value"

This parameter is for setting the customized colour of LED indication, user up to define 5 colours.

Options: #000000#FFFFFF

5.5. Parameter window“Logic function”

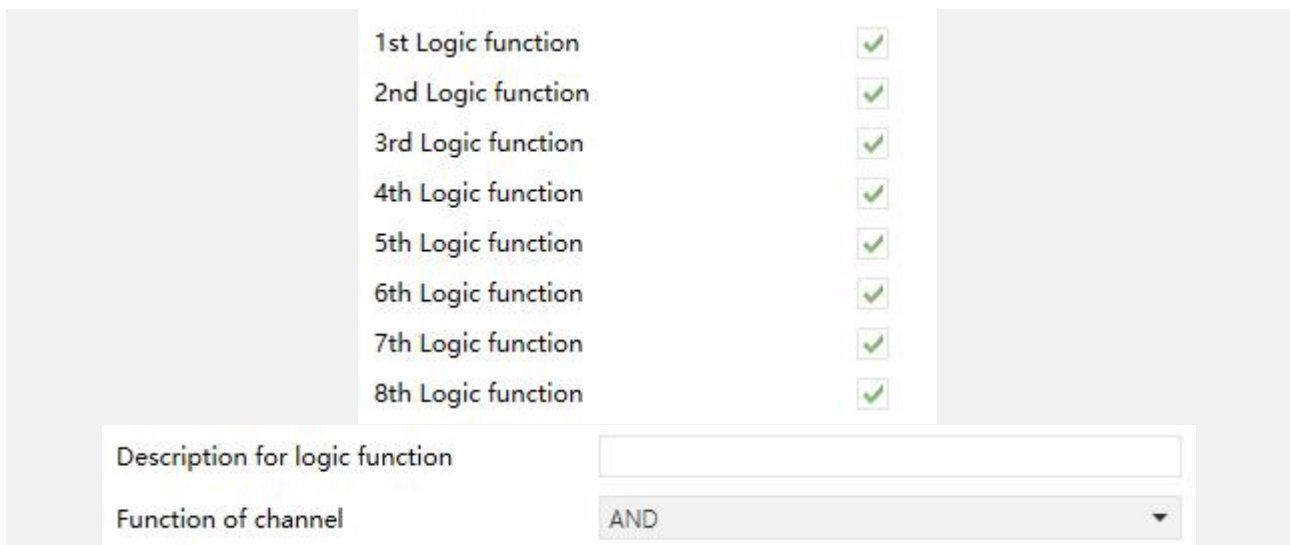

Fig.5.5 “Logic function” Parameter window

Parameter“1st/2nd/3rd... Logic function”

This parameter is for setting the setting interface of logic function, display corresponding logic function page when select. Up to enable 8 logic functions.

Parameter“Description for logic function”

This parameter is for setting the name description for logic function, up to input 30 characters.

Parameter“Function of channel”

This parameter is for setting function of the channel. Options:

AND

OR

XOR

Gate forwarding

Threshold comparator

Format convert

Gate function

Delay function

Staircase lighting

AND/OR/XOR: as the parameter is similar to the communication object (only the logic algorithm is different), the following parameters taking one options for example.

5.5.1. "AND/OR/XOR"

Description for logic function	<input type="text"/>
Function of channel	AND ▾
Input a	Disconnected ▾
Default value	<input checked="" type="radio"/> 0 <input type="radio"/> 1
Input b	Disconnected ▾
Default value	<input checked="" type="radio"/> 0 <input type="radio"/> 1
Input c	Disconnected ▾
Default value	<input checked="" type="radio"/> 0 <input type="radio"/> 1
Input d	Disconnected ▾
Default value	<input checked="" type="radio"/> 0 <input type="radio"/> 1
Input e	Disconnected ▾
Default value	<input checked="" type="radio"/> 0 <input type="radio"/> 1
Input f	Disconnected ▾
Default value	<input checked="" type="radio"/> 0 <input type="radio"/> 1
Input g	Disconnected ▾
Default value	<input checked="" type="radio"/> 0 <input type="radio"/> 1
Input h	Disconnected ▾
Default value	<input checked="" type="radio"/> 0 <input type="radio"/> 1
<hr/>	
Result is inverted	<input type="checkbox"/>
Read input object value after bus voltage recovery	<input type="checkbox"/>
Output send when	<input checked="" type="radio"/> Receiving a new telegram <input type="radio"/> Every change of output object
Send delay time: Base	None ▾
Factor: 1..255	1 ▲▼

Fig.5.5.1 "AND/OR/XOR"

Parameter "Input a/b/c/d/e/f/g/h"

This parameter is for setting whether input x to calculate, whether to normally calculate or inverted calculate. Options:

Disconnected

Normal

Inverted

Disconnected: not to calculate.

Normal: to directly calculate the input value.

Inverted: invert the input value, then to calculate.

Note: not to invert the initiate value.

Parameter "Default value"

This parameter is for setting the initial value of logic input x. Options:

0

1

Parameter "Result is inverted"

This parameter is for setting whether to invert the logic calculation result.

Disable: output directly.

Enable: output after inverting.

Parameter "Read input object value after bus voltage recovery"

This parameter is for setting whether to send the read request to the logic input object after device voltage recovery or finish programming.

Parameter "Output send when"

This parameter is for setting the condition of sending logic result. Options:

Receiving a new telegram

Every change of output object

Receiving a new telegram: every time the object received a new input value will the logic result be sent to the bus;

Every change of output object: only when logic result has changed will it be sent to the bus.

Note: when in the first time to logic calculate, the logic result will be sent even if it has no change.

Parameter "Send delay time"

Base: **None**

0.1s

1s

...

10s

25s

Factor: **1..255**

This parameter is for setting the delay time for sending the logic calculation result to the bus. Delay time = Base × Factor, if option "None" of Base is selected, then there is no delay.

5.5.2. "Gate forwarding"

Description for logic function	<input type="text"/>
Function of channel	Gate forwarding ▼
Object type of Input/Output	1bit ▼
Default scene NO. of Gate after startup [1~64,0=inactive]	0 ▲▼
<hr/>	
1->Gate trigger scene NO. is [1~64,0=inactive]	0 ▲▼
Input A send on	Output A ▼
Input B send on	Output B ▼
Input C send on	Output C ▼
Input D send on	Output D ▼
<hr/>	
2->Gate trigger scene NO. is [1~64,0=inactive]	0 ▲▼
Input A send on	Output A ▼
Input B send on	Output B ▼
Input C send on	Output C ▼
Input D send on	Output D ▼

Fig.5.5.2 "Gate forwarding"

Parameter "Object type of Input/Output"

This parameter is for setting the object type of input/output. Options:

1bit

4bit

1byte

Parameter "Default scene NO. of Gate after startup [1~64,0=inactive]"

This parameter is for setting the initial scene where logical gate forwarding can be performed by default after device starts, which needs to be configured in the parameters.

Options: **1..64, 0=inactive**

Note: gate scene is recommended to be selected before operating, or it will enable the initiate scene by default.

Parameter "z->Gate trigger scene NO. is [1~64,0=inactive]" (z=1~8)

This parameter is for setting scene number of logic gate forwarding. Up to 8 trigger scene number can be set for each logic. Options: **1..64, 0=inactive**

Parameter "Input A/B/C/D send on"

This parameter is for setting the output of input X (X=A/B/C/D) after gate forwarding. Options:

Output A

Output B

...

Output B,C,D

According to the options, one input can be forwarded into one or more outputs, the output value is the same as the input value.

5.5.3. "Threshold comparator"

Description for logic function	<input type="text"/>
Function of channel	Threshold comparator
Threshold value data type	1byte unsigned value (DPT5.010)
Threshold value	0
If Object value < Threshold value	Do not send telegram
If Object value = Threshold value	Do not send telegram
If Object value != Threshold value	Do not send telegram
If Object value > Threshold value	Do not send telegram
If Object value <= Threshold value	Do not send telegram
If Object value >= Threshold value	Do not send telegram
Output send when	<input checked="" type="radio"/> Receiving a new telegram <input type="radio"/> Every change of output object
Send delay time: Base	None
Factor: 1..255	1

Fig.5.5.3 "Threshold comparator"

Parameter "Threshold value data type"

This parameter is for setting the threshold value data type. Options:

- | | |
|--|--|
| 4bit value (DPT3.007) | 4byte unsigned value[0..4294967295] |
| 1byte unsigned value (DPT5.010) | Ext. temperature value (DPT 9.001) |
| 2byte unsigned value (DPT7.001) | Ext. humidity value (DPT 9.007) |
| 2byte signed value (DPT8.x) | Illuminance value (DPT 9.004) |
| 2byte float value (DPT9.x) | |

Parameter "Threshold value"

This parameter is for setting threshold value, the range depends on the data type. Options:

- 4bit value (DPT3.007) 0..15 / 1byte unsigned value (DPT5.010) 0..255 /**
2byte unsigned value (DPT7.001) 0..65535 / 2byte signed value (DPT8.x) -32768..32767 /
2byte float value (DPT9.x) -670760...670760 /
4byte unsigned value[0..4294967295] 0..4294967295 /
Ext. temperature value (DPT 9.001) -20..95°C / Ext. humidity value (DPT 9.007) 0..100% /

Illuminance value (DPT 9.004) 0..65535lux

Parameter "Hysteresis threshold value"

This parameter is visible when object datatype is selected "2byte float value (DPT9.x)", "Illuminance value (DPT 9.004)". Set the hysteresis threshold value. Options: **0..500**

Parameter "If Object value<Threshold value"

Parameter "If Object value=Threshold value"

Parameter "If Object value!=Threshold value"

Parameter "If Object value>Threshold value"

Parameter "If Object value<=Threshold value"

Parameter "If Object value>=Threshold value"

This parameter is for setting the logic result value that should be sent when threshold value Less than, equal to, not equal to, greater than, less than or equal to the setting valve. When object datatype is selected "2byte float value (DPT9.x)", can only set the object value less than or greater than threshold value. Options:

Do not send telegram

Send value "0"

Send value "1"

Do not send telegram: not consider to select this option;

Send value "0"/"1": when condition is satisfied, send telegram 0 or 1.

If there is a conflict between the setting options between parameters, the base on the value that should be sent when reach the final parameter condition. **For example: parameter "If Object value=Threshold value" is set to be "Send value "0" "; parameter "If Object value<=Threshold value" is set to be "Send value "1" "; when object value is equal to the threshold value, then the logic result will send "1".**

Parameter "Output send when"

This parameter is for setting the condition of sending logic result. Options:

Receiving a new telegram

Every change of output object

Receiving a new telegram: every time the object received a new input value will the logic result be sent to the bus;

Every change of output object: only when logic result has changed will it be sent to the bus.

Note: when in the first time to logic algorithm, the logic result will be sent even if it has no change.

Parameter "Send delay time"

Base: **None**

0.1s

1s

...

10s

25s

Factor: **1..255**

This parameter is for setting the delay time for sending the logic algorithm result to the bus. Delay time = Base x Factor, if option "None" of Base is selected, then there is no delay.

5.5.4. "Format convert"

Description for logic function	<input type="text"/>
Function of channel	Format convert
Function	2x1Bit-->1x2Bit
Output send when	<input checked="" type="radio"/> Receiving a new telegram <input type="radio"/> Every change of output object

Fig.5.5.4 "Format convert"

Parameter "Function"

This parameter is for setting the format convert type. Options:

2x1bit-->1x2bit

8x1bit-->1x1byte

1x1byte-->1x2byte

2x1byte-->1x2byte

2x2byte-->1x4byte

1x1byte-->8x1bit

1x2byte-->2x1byte

1x4byte-->2x2byte

1x3byte-->3x1byte

3x1byte-->1x3byte

Parameter "Output send when"

This parameter is for setting the condition of sending logic result. Options:

Receiving a new telegram

Every change of output object

Receiving a new telegram: every time the object received a new input value will the logic result be sent to the bus.

Every change of output object: only when logic result has changed will it be sent to the bus.

Note: when in the first time to logic algorithm, the logic result will be sent even if it has no change.

5.5.5. "Gate function"

Description for logic function	<input type="text"/>
Function of channel	Gate function ▾
Object type of Input/Output	1bit[On/Off] ▾
Filter function	Deactivate ▾
Value output	<input checked="" type="radio"/> Normal <input type="radio"/> Inverted
Gate object value	<input checked="" type="radio"/> Normal <input type="radio"/> Inverted
Gate status after voltage recovery	<input type="radio"/> OFF <input checked="" type="radio"/> ON
Save input signal when gate close	<input type="checkbox"/>

Fig.5.5.5 "Gate function"

Parameter "Object type of Input/Output"

This parameter is for setting the object type of input/output. Options:

- 1bit[On/Off]**
- 1byte[0..100%]**
- 1byte[0..255]**
- 2byte[Float]**
- 2byte[0..65535]**

Parameter "Filter function"

This parameter is visible when "1bit[On/Off]" is selected. Set whether to filter On or Off telegram, only pass one of them or pass all. Options:

- Deactivate**
- On filter out**
- Off filter out**

Deactivate: Do not filter the On or Off telegrams.

On filter out: Off can pass, On cannot pass.

Off filter out: On can pass, Off cannot pass.

Parameter "Value output"

This parameter is visible when "1bit[On/Off]" is selected. Set whether to invert the value then output it. Options:

Normal

Inverted

Parameter "Gate object value"

This parameter is for setting whether to invert the gate object value then output it. Options:

Normal

Inverted

Parameter "Gate status after voltage recovery"

This parameter is for setting the gate status after voltage recovery. Options:

Disable

Enable

Parameter "Save input signal when gate close"

This parameter is for setting whether to save input signal on gate close.

Disable: disable to save the input, the input values received during the gate closing period are ignored;

Enable: enable to save the input, the input values received during the gate closing period are output when gate is open (whether the input value is changed or not).

Note: During the period when the gate is closed, the received filtered input values are not saved.

After the gate is opened, the valid input values received are output.

5.5.6. "Delay function"

Description for logic function	<input type="text"/>
Function of channel	Delay function ▼
Object type of Input/Output	1bit[On/Off] ▼
Delay time [0..6500]	10 s

Fig.5.5.6 "Delay function"

Parameter "Object type of Input/Output"

This parameter is for setting the object type of input/output. Options:

1bit[On/Off]

1byte[0..100%]

1byte[0..255]

2byte[Float]

2byte[0..65535]

Parameter "Delay time [0..6500]s"

This parameter is for setting the delay time that output object forwards the value when the input object receives the telegram. Options: **0..6500 s**

Note: Receive telegram again in delay time, re-timing.

5.5.7. "Staircase lighting"

Description for logic function	<input type="text"/>
Function of channel	Staircase lighting ▾
Trigger value	1 ▾
Object type of output	<input checked="" type="radio"/> 1bit <input type="radio"/> 1byte
Duration time of staircase lighting [10..6500]	10 <input type="text"/> s
Send value 1 when trigger	<input type="radio"/> OFF <input checked="" type="radio"/> ON
Send value 2 after duration time	<input checked="" type="radio"/> OFF <input type="radio"/> ON
Retriggering	<input checked="" type="checkbox"/>

Fig.5.5.7 "Staircase lighting"

Parameter "Trigger value"

This parameter is for setting the telegram value of the object "Trigger value". Options:

0

1

0 or 1

Parameter "Object type of output"

This parameter is for setting the object type of output. Options:

1bit

1byte

Parameter "Duration time of staircase lighting[10..6500]s"

This parameter is for setting duration time of staircase lighting after the stair light power on.

Options: **10..6500**

Parameter "Send value 1 when trigger"

Parameter "Send value 2 after duration time"

These parameters are for setting the value to send. Send value 1 when trigger, and then send value 2 after duration time. Options display according to the output object datatype.

When 1 bit, options:

OFF

ON

When 1 byte , options: **0..255**

Parameter "Retriggering"

This parameter is for setting whether to trigger re-timing when received trigger value in delay time.

5.6. Parameter window“Scene Group”

Scene Group 1 Function	<input checked="" type="checkbox"/>
Scene Group 2 Function	<input type="checkbox"/>
Scene Group 3 Function	<input type="checkbox"/>
Scene Group 4 Function	<input type="checkbox"/>
Scene Group 5 Function	<input type="checkbox"/>
Scene Group 6 Function	<input type="checkbox"/>
Scene Group 7 Function	<input type="checkbox"/>
Scene Group 8 Function	<input type="checkbox"/>
Output 1 Function	<input checked="" type="checkbox"/>
Output 2 Function	<input type="checkbox"/>
Output 3 Function	<input type="checkbox"/>
Output 4 Function	<input type="checkbox"/>
Output 5 Function	<input type="checkbox"/>
Output 6 Function	<input type="checkbox"/>
Output 7 Function	<input type="checkbox"/>
Output 8 Function	<input type="checkbox"/>
Description for Output 1 function	<input type="text"/>
Object type of Output 1	1bit
1->Output 1 trigger scene NO. is [1~64,0=inactive]	<input type="text" value="0"/>
Object value of Output 1	<input checked="" type="radio"/> 0 <input type="radio"/> 1
Delay time for sending [0..255]	<input type="text" value="0"/> *0.1s
2->Output 1 trigger scene NO. is [1~64,0=inactive]	<input type="text" value="0"/>
Object value of Output 1	<input checked="" type="radio"/> 0 <input type="radio"/> 1
Delay time for sending [0..255]	<input type="text" value="0"/> *0.1s

Fig.5.6 “Scene Group” Parameter window

Parameter“Scene Group x Function”(x=1~8)

This parameter is for setting whether to enable scene group x function, up to 8 scene groups.

Parameter“Output y Function”(y=1~8)

This parameter is for setting whether to enable output y of scene group x, up to 8 output functions for each scene group.

As 8 group functions are the same, and 8 output functions of each group as well, the following description only about one output of a group.

Parameter "Description for Output y function" (y=1~8)

This parameter is for setting the name description for output y of group x, up to input 30 characters.

Parameter "Object type of Output y" (y=1~8)

This parameter is for setting the object type of output y of group x. Options:

1bit

1byte

2byte

RGB

RGBW

Parameter "Object datatype"

This parameter is for setting the datatype of 1byte or 2byte.

When the datatype is 1byte, options:

1byte unsigned value

HVAC mode

When the datatype is 2byte, options:

2byte unsigned value

Temperature value

Parameter "z->Output y trigger scene NO. is [1~64,0=inactive]" (z=1~8)

This parameter is for setting the triggered scene number of output y of group x. Up to 8 triggered scene of each output can be configured. Options: **0..64, 0=inactive**

Parameter "Object value of Output y"

This parameter is for setting the output value, the range depends on the data type of output y.

When the datatype is 1bit, options: **0..1**

When the datatype is 1byte-1byte unsigned value, options: **0..255**

When the datatype is 1byte-HVAC mode, options:

Comfort mode

Standby mode

Economy mode

Frost/heat protection

When the datatype is 2byte-2byte unsigned value, options: **0..65535**

When the datatype is 2byte-Temperature value, options:

-5°C

-4°C

...

45°C

—Parameter“RGB value of Output y”

When the datatype is RGB this parameter is visible, used for setting the RGB value of output y.

Options: **#000000...#FFFFFF**

—Parameter“White value of Output y”

When the datatype is RGBW this parameter is visible, used for setting the white value of output y.

Options: **0.255**

—Parameter“Delay time for sending [0..255]*0.1s”

This parameter is for setting the delay time for sending the output value to the bus. Options: **0..255**

Chapter 6 Description of Communication Object

The communication object is the medium to communicate other device on the bus, namely only the communication object can communicate with the bus.

NOTE: “C” in “Flag” column in the below table means enable the communication function of the object; “W” means value of object can be written from the bus; “R” means the value of the object can be read by the other devices; “T” means the object has the transmission function; “U” means the value of the object can be updated.

6.1. “General”Communication Object

Number	Name	Object Function	Description	Group Address	Length	C	R	W	T	U	Data Type	Priority
1	General	In operation			1 bit	C	R	-	T	-	switch	Low
4	General	Screen brightness			1 byte	C	-	W	-	-	percentage (0..100%)	Low
148	Extension function	Panel locking			1 bit	C	-	W	-	-	enable	Low
149	Extension function	Screen on/off			1 bit	C	-	W	-	-	switch	Low
150	Extension function	Night mode			1 bit	C	-	W	T	U	day/night	Low
152	Extension function	Dis/En Proximity function			1 bit	C	-	W	-	-	enable	Low
153	Extension function	Proximity input			1 bit	C	-	W	-	-	switch	Low
154	Extension function	Proximity output			1 byte	C	-	-	T	-	counter pulses (0..255)	Low
158	Extension function	Locking scene			1 byte	C	-	-	T	-	scene number	Low
159	Extension function	Screen off scene			1 byte	C	-	-	T	-	scene number	Low
161	Extension function	RGB light indication trigger			1 bit	C	-	W	-	-	trigger	Low
162	Extension function	RGB light color setting			3 bytes	C	-	W	-	-	RGB value 3x(0..255)	Low
163	Extension function	RGB light flashing			1 bit	C	-	W	-	-	trigger	Low
164	Screensaver-Items 1	1byte unsigned value			1 byte	C	-	W	T	U	counter pulses (0..255)	Low

Fig.6.1 “General”Communication Object

NO.	Object Function	Name	Data Type	Flag	DPT
1	In operation	General	1bit	C,R,T	1.001 switch
<p>The communication object is used to periodically send a telegram “1” to the bus to indicate this device in normal operation. The period is set by the parameter.</p>					
4	Screen brightness	General	1byte	C,W	5.001 percentage(0..100%)
<p>The communication object is used to modify the brightness of current mode. For example, if current is normal mode, it is only updated the brightness in normal mode, while night mode it is still determined to its parameter.</p> <p>Note: brightness in screen saver can not be modified via the object.</p> <p>Brightness range: 10~100%, when telegram is below 10%, output 10% directly.</p>					
148	Panel locking	Extension function	1bit	C,W	1.003 enable
<p>The communication object is visible when panel locking function is enabled, used to lock the</p>					

panel. After screen is locked, the operation on the panel will not be responded, but can still receive the bus telegram. Telegram value is defined by the parameter.					
149	Screen on/off	Extension function	1bit	C,W	1.001 switch
<p>The communication object is visible when the parameter "Delay time for turn off screen" is set to 0, used to receive the telegrams from bus to control screen on/off. Telegram value:</p> <p style="text-align: center;">0—off</p> <p style="text-align: center;">1—on</p>					
150	Night mode	Extension function	1bit	C,W C,W,T, U	1.024 day/night
<p>This communication object is used to send day/night status to the bus and receive the telegram value via bus to switch. If device restart, the object sends status request telegram. Telegram value is defined by the parameter.</p>					
152	Dis/En Proximity function	Extension function	1bit	C,W	1.003 enable
<p>This communication object is visible when proximity function is enabled, used to enable/disable proximity function.</p>					
153	Proximity input	Extension function	1bit	C,W	1.001 switch
<p>This communication object is visible when the parameter "The Proximity function triggered via" is not selected "sensor", used to receive the telegram value from bus.</p> <p style="text-align: center;">1—Trigger proximity function</p> <p style="text-align: center;">0—No available</p>					
154	Proximity output	Extension function	1bit 1byte 2byte	C,T	1.001 switch 5.010 counter pulses 17.001 scene number 5.001 percentage
<p>The communication object is determined by the parameter "Object type of output value". When</p>					

proximity function is triggered, the object can send the parameter setting value(1byte/2byte) or (1bit) to the bus separately. The range of value is determined by the selected data type.

158	Locking scene	Extension function	1byte	C,T	17.001 scene number									
The communication object is visible when panel locking function and external scene function are enabled, used to recall external scene command.														
159	Screen off scene	Extension function	1byte	C,T	17.001 scene number									
The communication object is visible when screen off and external scene function are enabled, used to recall external scene command.														
161	RGB light indication trigger	Extension function	1bit	C,W	1.017 trigger									
When RGB light is configured independently, it is triggered by 1bit object, and telegram value is set by the parameter.														
162	RGB light color setting	Extension function	3byte	C,W	232.600 RGB value 3x(0..255)									
<p>This communication object is visible when the parameter "Indication work mode when active" is selected "Permanent on/Slowly breathing" and parameter "Colour setting" is selected "receive a 3 byte value", used to receive the brightness value of RCB multi-colour lamp from the bus.</p> <p>3-Byte Code for RGB Dimming Object Data Type: U8 U8 U8, as follows:</p> <table border="1" style="margin-left: auto; margin-right: auto;"> <tr> <td style="text-align: center;">3_{MSB}</td> <td style="text-align: center;">2</td> <td style="text-align: center;">1_{LSB}</td> </tr> <tr> <td style="text-align: center;">R</td> <td style="text-align: center;">G</td> <td style="text-align: center;">B</td> </tr> <tr> <td style="text-align: center;">UUUUUUUU</td> <td style="text-align: center;">UUUUUUUU</td> <td style="text-align: center;">UUUUUUUU</td> </tr> </table> <p>R: red dimming value; G: green dimming value; B: blue dimming value.</p>						3 _{MSB}	2	1 _{LSB}	R	G	B	UUUUUUUU	UUUUUUUU	UUUUUUUU
3 _{MSB}	2	1 _{LSB}												
R	G	B												
UUUUUUUU	UUUUUUUU	UUUUUUUU												
163	RGB light flashing	Extension function	1bit	C,W	1.017 trigger									
This communication object is visible when flashing function is enabled, used to trigger the flashing alarm function of the RGB light.														
164	Temperature value	Screensaver-Items	2byte	C,W,T,	9.001 temperature									
	Humidity value	x(x=1~3)	2byte	U	9.007 humidity									

	1bit value		1bit		1.001 switch
	1byte percent value		1byte		5.001
	1byte unsigned value		1byte		percentage(0..100%)
	2byte unsigned value		2byte		5.010 counter pulses
	2byte float value		2byte		7.001 pulses
	4byte unsigned value		4byte		9.x float value
	4byte float value		4byte		12.001 counter pulses
	14byte value		14byte		14.x float value
					16.001 character string (ISO 8859-1)
<p>The communication object is used to receive the corresponding value from the bus and update it to the display. Object datatype and telegram range are determined by the parameter setting.</p>					

Table6.1 "General"Communication Object

6.2. "Internal sensor"Communication Object

Number	Name	Object Function	Description	Group Address	Length	C	R	W	T	U	Data Type	Priority
5	Internal sensor	Temperature value			2 bytes	C	R	-	T	-	temperature (°C)	Low
6	Internal sensor	Low temperature alarm			1 bit	C	R	-	T	-	alarm	Low
7	Internal sensor	High temperature alarm			1 bit	C	R	-	T	-	alarm	Low

Fig.6.2 "Internal sensor"Communication Object

NO.	Object Function	Name	Data Type	Flag	DPT
5	Temperature value	Internal sensor	2byte	C,R,T	9.001 temperature
<p>The communication object is used for transmitting the temperature value detected by the built-in temperature sensor of the device to the bus. Range:-50~99.8°C</p>					
6	Low temperature alarm	Internal sensor	1bit	C,R,T	1.005 alarm
<p>This communication object is visible when the parameter "Send alarm telegram for low/high temperature" is not selected "No respond", used to send the low temperature alarm signal to bus, when temperature lower than low threshold that defined by parameter.</p>					
7	High temperature alarm	Internal sensor	1bit	C,R,T	1.005 alarm
<p>This communication object is visible when the parameter "Send alarm telegram for low/high temperature" is not selected "No respond", used to send the high temperature alarm signal to bus, when temperature higher than high threshold that defined by parameter.</p>					

Table6.2 "Internal sensor"Communication Object

6.3. "Function setting"Communication Object

6.3.1. "FCU"Communication Object

When the work mode is "Master", the read requests of external sensor, fan speed, the window and the presence are sent to the bus after voltage recovery, as well as power on/off status, actual temperature (combined), current setpoint temperature, heating/cooling status, operation mode, fan speed and fan automatic status.

When the work mode is "Single", the read requests of external sensor, fan speed, the window and the presence are sent to the bus after voltage recovery, as well as the actual temperature (combined).

When the work mode is "Slave", send the status requests of these functions after voltage recovery: power on/off, the external sensor, current setpoint temperature, heating/cooling control mode, operation mode, fan speed and fan automatic operation.

	Number	Name	Object Function	Description	Group Address	Length	C	R	W	T	U	Data Type	Priority
➡	167	FCU 1	Locking function			1 bit	C	-	W	-	-	enable	Low
➡	168	FCU 1	Power on/off			1 bit	C	-	W	-	-	switch	Low
➡	169	FCU 1	External temperature sensor			2 bytes	C	-	W	T	U	temperature (°C)	Low
➡	170	FCU 1	Base temperature setpoint			2 bytes	C	-	W	-	U	temperature (°C)	Low
➡	171	FCU 1	Heating/Cooling mode			1 bit	C	-	W	-	U	cooling/heating	Low
➡	172	FCU 1	Operation mode			1 byte	C	-	W	-	U	HVAC mode	Low
➡	173	FCU 1	Comfort mode			1 bit	C	-	W	-	U	enable	Low
➡	174	FCU 1	Standby mode			1 bit	C	-	W	-	U	enable	Low
➡	175	FCU 1	Economy mode			1 bit	C	-	W	-	U	enable	Low
➡	176	FCU 1	Frost/Heat protection mode			1 bit	C	-	W	-	U	enable	Low
➡	177	FCU 1	Fan speed, status			1 byte	C	-	W	T	U	percentage (0..100%)	Low
➡	178	FCU 1	Fan Automatic operation, status			1 bit	C	-	W	T	U	enable	Low
➡	179	FCU 1	Extended comfort mode			1 bit	C	-	W	-	-	acknowledge	Low
➡	180	FCU 1	Window contact			1 bit	C	-	W	T	U	window/door	Low
➡	181	FCU 1	Presence detector			1 bit	C	-	W	T	U	occupancy	Low
➡	183	FCU 1	Scene			1 byte	C	-	W	-	-	scene control	Low
➡	184	FCU 1	Power on/off, status			1 bit	C	R	-	T	-	switch	Low
➡	185	FCU 1	Actual temperature			2 bytes	C	R	-	T	-	temperature (°C)	Low
➡	186	FCU 1	Current base setpoint temperature...			2 bytes	C	R	-	T	-	temperature (°C)	Low
➡	187	FCU 1	Current setpoint adjustment, status			2 bytes	C	R	-	T	-	temperature (°C)	Low
➡	188	FCU 1	Heating/Cooling mode, status			1 bit	C	R	-	T	-	cooling/heating	Low
➡	189	FCU 1	Operation mode, status			1 byte	C	R	-	T	-	HVAC mode	Low
➡	190	FCU 1	Comfort mode, status			1 bit	C	R	-	T	-	enable	Low
➡	191	FCU 1	Standby mode, status			1 bit	C	R	-	T	-	enable	Low
➡	192	FCU 1	Economy mode, status			1 bit	C	R	-	T	-	enable	Low
➡	193	FCU 1	Frost/Heat protection mode, status			1 bit	C	R	-	T	-	enable	Low
➡	194	FCU 1	Heating control value			1 byte	C	R	-	T	-	percentage (0..100%)	Low
➡	195	FCU 1	Cooling control value			1 bit	C	R	-	T	-	switch	Low
➡	196	FCU 1	Fan speed			1 byte	C	R	-	T	-	percentage (0..100%)	Low
➡	197	FCU 1	Fan Automatic operation			1 bit	C	R	-	T	-	enable	Low

Fig.6.3.1 "FCU"Communication Object

NO.	Object Function	Name	Data Type	Flag	DPT
167	Locking function	FCU	1bit	C,W	1.003 enable
<p>The communication object is used to lock/unlock FCU control function. Telegrams:</p> <p>0—Lock</p> <p>1—Unlock</p>					
168	Power on/off	FCU	1bit	C,W,T,U	1.001 switch
168	Power on/off, status	FCU	1bit	C,W,T,U	1.001 switch
<p>These communication object are visible when “Via object only” and Via both button and object” is selected.</p> <p>When the work mode is “Master” or “Single”, the flag is C,W, “Power on/off” is visible, used to receive telegram from bus to control power on/off.</p> <p>When the work mode is “Slave”, the flag is C,W,T,U, “Power on/off, status” is visible, used to receive the status of power on/off, which is fed back from the controller on the bus.</p> <p>Telegrams:</p> <p>1—On</p> <p>0—Off</p>					
169	External temperature sensor	FCU	2byte	C,W,T,U	9.001 temperature
<p>The communication object is visible when “External sensor” and “Internal and External sensor combination” is selected, used to receive the room temperature from the bus, and send read request cyclically, and feedback to screen display.</p>					
170	Current temperature setpoint Base temperature setpoint	FCU	2byte	C,W,U	9.001 temperature
170	Current temperature setpoint, status	FCU	2byte	C,W,T,U	9.001 temperature
<p>When the work mode is “Master”, the flag is C,W,U:</p> <p>“Current temperature setpoint” is visible when operation mode is not enabled, and under absolute adjustment, used to modify the base value of the set temperature; and to modify set temperature value</p>					

of current room operation mode when absolute adjustment.

“Base temperature setpoint” is visible only when relative adjustment, used to modify the base value of the set temperature, that is, the temperature setting value of the comfort mode, and the setpoint temperature of the standby mode and the economy mode changes according to the relative change. In the protection mode, only the temperature setting value of the protection mode is modified.

When the work mode is “Slave”, the flag is **C,W,T,U**, only “Current temperature setpoint, status” is visible, used to receive the status of current setpoint temperature, which is fed back from the controller on the bus.

While “Single”, no these objects.

171	Heating/Cooling mode	FCU	1bit	C,W,U	1.100 cooling/heating
171	Heating/Cooling mode, status	FCU	1bit	C,W,T,U	1.100 cooling/heating

These communication object are visible when control mode is “Heating and Cooling” and “Only via object” is selected.

When the work mode is “Master” or “Single”, the flag is **C,W,U**, “Heating/Cooling mode” is visible, used to receive telegram from bus to control heating/cooling mode.

When the work mode is “Slave”, the flag is **C,W,T,U**, “Heating/Cooling mode, status” is visible, used to receive the status of heating/cooling mode, which is fed back from the controller on the bus.

Telegrams:

1—Heating

0—Cooling

172	Operation mode	FCU	1byte	C,W,U	20.102 HVAC mode
172	Operation mode, status	FCU	1byte	C,W,T,U	20.102 HVAC mode
173	Comfort mode	FCU	1bit	C,W,U	1.003 enable
174	Standby mode	FCU	1bit	C,W,U	1.003 enable
175	Economy mode	FCU	1bit	C,W,U	1.003 enable
176	Frost/Heat protection mode	FCU	1bit	C,W,U	1.003 enable

When 1byte, obj.172 is visible:

When the work mode is “Master” or “Single”, the flag is **C,W,U**, “Operation mode” is visible, used to receive telegram from bus to control operation mode.

When the work mode is “Slave”, the flag is **C,W,T,U**, “Operation mode, status” is visible, used to receive the status of operation mode., which is fed back from the controller on the bus.

Telegram value: 1-Comfort, 2-Standby, 3-Economy, 4-Protection, other reserved.

When 1bit, used to receive telegrams from bus to control each operation mode:

Obj.173—Comfort mode

Obj.174—Standby mode

Obj.175—Economy mode

Obj.176—Protection mode

When the object receives the telegram “1”, the corresponding mode is activated and the display status of the mode on the screen will also be updated to the corresponding mode. When 1 bit standby object is not enable, three objects comfort, economy, protection all send 0 to activate standby mode. When 1 bit standby object is enable, only standby object sends 1 to activate standby mode, 0 is ignored.

When the work mode is “Single” or “Slave”, these four 1bit objects are not visible.

177	Fan speed, status	FCU	1byte	C,W,T,U	5.001 percentage 5.100 fan stage
<p>The communication object is visible when fan function enabled, used to receive the current fan speed from the bus. Telegram value is determined by parameter setting datatype.</p>					
178	Fan automatic operation, status	FCU	1bit	C,W,T,U	1.003 enable
<p>The communication object is visible when automatic operation function enabled, used to receive feedback status of fan automatic fan operation from the bus.</p> <p>Telegrams:</p> <p style="padding-left: 40px;">1—Automatic</p> <p style="padding-left: 40px;">0—Cancel automatic</p>					
179	Extended comfort mode	FCU	1bit	C,W	1.016 acknowledge

<p>The communication object is visible when the “Extended comfort mode [0...255, 0=inactive]”>0, used to triggering time to extended comfort mode. Telegrams:</p> <p style="margin-left: 40px;">1—Activate comfort mode</p> <p style="margin-left: 40px;">0—No available</p> <p>Activate comfort mode when the object receives telegram 1. If receive again telegram 1 in delay time, time will be timed again. And return the previous operation mode from comfort mode once finish timing. If there is a new operation mode in delay time, exit the comfort mode.</p> <p>Change the operation mode will exit the timing, but switch the heating/cooling will not.</p> <p>When the work mode is “Slave”, this object is not visible.</p>					
180	Window contact	FCU	1bit	C,W,T,U	1.019 Window/door
<p>The communication object is visible when the window contact input function is enabled, used to receive the switch status of window contact. Telegrams:</p> <p style="margin-left: 40px;">1—Open window</p> <p style="margin-left: 40px;">0—Close window</p>					
181	Presence detector	FCU	1bit	C,W,T,U	1.018 occupancy
<p>The communication object is visible when the bus presence detector function is enabled, used to receive the room occupancy status from presence detector. Telegrams:</p> <p style="margin-left: 40px;">1—Occupied</p> <p style="margin-left: 40px;">0—Unoccupied</p>					
183	Scene	FCU	1byte	C,W	18.001 scene control
<p>The communication object is visible when scene function enabled, used to recall/storage scene via bus.</p> <p>When the work mode is “Slave”, this object is not visible.</p>					
184	Power on/off, status	FCU	1bit	C,R,T	1.001 switch
184	Power on/off	FCU	1bit	C,T	1.001 switch
<p>These communication object are visible when “Via button only” or “Via both button and object” is</p>					

<p>selected.</p> <p>When the work mode is “Master” or “Single”, the flag is C,R,T, “Power on/off, status” is visible, used to feed back status of power on/off to the bus.</p> <p>When the work mode is “Slave”, the flag is C,T, “Power on/off” is visible, used to send the power on/off telegram to bus, to control the controller on the KNX bus.</p>						
185	Actual temperature	FCU	2byte	C,R,T	9.001 temperature	
<p>The communication object is visible when room temperature reference reference from combination of internal and external sensor, used to transmitting the actual temperature value detected by the combination temperature sensor of the device to the bus.</p>						
186	Current base setpoint temperature, status	FCU	2byte	C,R,T	9.001 temperature	
<p>When the work mode is “Master”, the communication object is visible when relative adjustment is selected, used to send the current base setpoint temperature value to the bus.</p> <p>When the work mode is “Slave” or “Single”, this object is not visible.</p>						
187	Current setpoint adjustment, status	FCU	2byte	C,R,T	9.001 temperature	
187	Current setpoint adjustment	FCU	2byte	C,T	9.001 temperature	
<p>When the work mode is “Master”, the flag is C,R,T, “Current setpoint adjustment, status” is visible, used to feed back status of current setpoint temperature to the bus.</p> <p>When the work mode is “Slave”, the flag is C,T, “Current setpoint adjustment” is visible, used to send the current setpoint temperature to bus.</p> <p>While “Single”, this object is not visible.</p>						
188	Heating/Cooling mode, status	FCU	1bit	C,R,T	1.100 cooling/heating	
<p>When the work mode is “Master” or “Single”, the communication object is visible when control mode is “Heating and Cooling” and “Only via object” is not selected, used to send telegrams from switching cooling and heating functions to the bus. Telegram value:</p> <p style="margin-left: 40px;">1 -- Heating</p> <p style="margin-left: 40px;">0 -- Cooling</p>						

While "Slave", this object is not visible.					
189	Operation mode, status	FCU	1byte	C,R,T	20.102 HVAC mode
189	Operation mode	FCU	1byte	C,T	20.102 HVAC mode
190	Comfort mode, status	FCU	1bit	C,R,T	1.003 enable
191	Standby mode, status	FCU	1bit	C,R,T	1.003 enable
192	Economy mode, status	FCU	1bit	C,R,T	1.003 enable
193	Frost/Heat protection mode, status	FCU	1bit	C,R,T	1.003 enable
<p>The communication object is visible when room temperature operation mode enabled.</p> <p>When 1byte, obj.189 is visible:</p> <p>When the work mode is "Master" or "Single", the flag is C,R,T, "Operation mode, status" is visible, used to feed back status of operation mode to the bus.</p> <p>When the work mode is "Slave", the flag is C,T, "Operation mode" is visible, used to send the operation mode of controller to bus.</p> <p>Telegrams: 1: Comfort mode; 2: Standby mode; 3: Economy mode; 4: Protection mode; other reserved.</p> <p>When 1bit:</p> <p>Switch to the corresponding mode, and the object of the corresponding mode sends the telegram "1" to the bus.</p> <p>When the work mode is "Single" or "Slave", these four 1bit objects are not visible.</p>					
194	Heating/cooling control value	FCU	1bit	C,R,T	1.001 Switch
	Heating control value		1byte		5.001 percentage
195	Cooling control value	FCU	1bit	C,R,T	1.001 Switch
			1byte		5.001 percentage
<p>These communication objects are used to send control value of heating or cooling function to the bus. Object is depending on the control mode and control system (2-pipe or 4 pipe) to display, and object datatype is according to parameter setting.</p> <p>When the work mode is "Slave", these two objects are not visible.</p>					

196	Fan speed	FCU	1byte	C,T C,R,T	5.001 percentage 5.100 fan stage
<p>The communication object is used to send control telegrams of the fan speed to the bus. The corresponding telegram value of each fan speed is defined by the parameter. Activate the corresponding fan speed on the panel, and send the corresponding telegram value of the fan speed to the bus.</p> <p>When the work mode is "Master", the flag is C,R,T; when "Slave" or "Single", the flag is C,T.</p>					
197	Fan automatic operation	FCU	1bit	C,T C,R,T	1.003 enable
<p>The communication object is visible when automatic operation function enabled, used to activate the fan automatic operation via the bus. Telegrams:</p> <p style="padding-left: 40px;">1—Automatic</p> <p style="padding-left: 40px;">0—Cancel automatic</p> <p>When the work mode is "Master", the flag is C,R,T; when "Slave" or "Single", the flag is C,T.</p>					

Table6.3.1 "FCU"Communication Object

6.3.2. "VRF"Communication Object

System needs to return to the status as before voltage failure when voltage recovery, as well as send these status requests: power on/off, mode, fan speed, setpoint temperature, external temperature sensor and vanes swing.

	Number	Name	Object Function	Description	Group Address	Length	C	R	W	T	U	Data Type	Priority
↔	198	VRF 1	Locking function			1 bit	C	-	W	-	-	enable	Low
↔	199	VRF 1	Power on/off, status			1 bit	C	-	W	T	U	switch	Low
↔	200	VRF 1	External temperature sensor			2 bytes	C	-	W	T	U	temperature (°C)	Low
↔	201	VRF 1	Current temperature setpoint, stat...			2 bytes	C	-	W	T	U	temperature (°C)	Low
↔	202	VRF 1	Control mode, status			1 byte	C	-	W	T	U	HVAC control mode	Low
↔	203	VRF 1	Fan speed, status			1 byte	C	-	W	T	U	percentage (0..100%)	Low
↔	204	VRF 1	Vanes swing (1-swing,0-stop), status			1 bit	C	-	W	T	U	start/stop	Low
↔	206	VRF 1	Scene			1 byte	C	-	W	-	-	scene control	Low
↔	207	VRF 1	Power on/off			1 bit	C	-	-	T	-	switch	Low
↔	208	VRF 1	Current setpoint adjustment			2 bytes	C	-	-	T	-	temperature (°C)	Low
↔	209	VRF 1	Fan speed			1 byte	C	-	-	T	-	percentage (0..100%)	Low
↔	210	VRF 1	Vanes swing (1-swing,0-stop)			1 bit	C	-	-	T	-	start/stop	Low
↔	211	VRF 1	Control mode			1 byte	C	-	-	T	-	HVAC control mode	Low

Fig.6.3.2 "VRF"Communication Object

NO.	Object Function	Name	Data Type	Flag	DPT
198	Locking function	VRF	1bit	C,W	1.003 enable
<p>The communication object is used to lock/unlock VRF control function. Telegrams:</p> <p>0—Lock</p> <p>1—Unlock</p>					
199	Power on/off, status	VRF	1bit	C,W,T,U	1.001 switch
<p>The communication object is used to receive the power on/off telegram of VRF from the bus. Telegrams:</p> <p>1—On</p> <p>0—Off</p>					
200	External temperature sensor	VRF	2byte	C,W,T,U	9.001 temperature
<p>The communication object is visible when the external sensor is selected, used to receive the room temperature from the bus, and send read request cyclically, and feedback to screen display.</p>					
201	Current temperature setpoint, status	VRF	1byte 2byte	C,W,T,U	5.010 counter pulses 9.001 temperature

The communication object is used to receive the current setpoint temperature value from the bus.					
202	Control mode, status	VRF	1byte	C,W,T,U	20.105 HVAC control mode
The communication object is used to receive the current control mode from the bus. Different telegram means different control mode: 0-Auto, 1- Heating, 3-Cooling, 9-Fan, 14-Dehumidity, other reserved.					
203	Fan speed, status	VRF	1byte	C,W,T,U	5.001 percentage 5.100 fan stage
The communication object is used to receive the current fan speed from the bus. Telegram value is determined by parameter setting datatype.					
204	Vanes swing (1-swing,0-stop), status	VRF	1bit	C,W,T,U	1.010 start/stop
The communication object is visible when swing function enabled, used to receive vanes swing status from the bus. Telegrams: 1—Swing 0—Stop					
206	Scene	VRF	1byte	C,W	18.001 scene control
The communication object is visible when scene function enabled, used to recall/storage scene via bus.					
207	Power on/off	VRF	1bit	C,T	1.001 switch
The communication object is used to send the power on/off telegram of VRF, to control VRF power on/off on the KNX bus.					
208	Current setpoint adjustment	VRF	2byte 1byte	C,T	5.001 percentage 5.100 fan stage
The communication object is used to adjust setpoint temperature via the bus, and send telegram value to the bus. Telegram value is determined by parameter setting datatype.					
209	Fan speed	VRF	1byte	C,T	5.001 percentage 5.100 fan stage

<p>The communication object is used to send control telegram of each fan speed to the bus. Telegram value is determined by parameter setting datatype.</p>					
210	Vanes swing (1-swing,0-stop)	VRF	1bit	C,T	1.010 start/stop
<p>The communication object is visible when swing function enabled, used to send telegram controlling vanes swing to the bus. Telegrams:</p> <p style="text-align: center;">1—Swing</p> <p style="text-align: center;">0—Stop</p>					
211	Control mode	VRF	1byte	C,T	20.105 HVAC control mode
<p>The communication object is used to send control telegram of each air condition mode to the bus. Different telegram means different control mode: 0-auto, 1-heating, 3-cooling, 9-fan, 14-dehumidification, 18-sleep, 19-refreshing, other reserved.</p>					

Table6.3.2 "VRF"Communication Object

6.3.3. “Floor heating”Communication Object

When the work mode is “Master”, the read requests of external sensor is sent to the bus after voltage recovery, as well as send the status of power on/off, actual temperature (combined), current setpoint temperature.

When the work mode is “Single”, the read requests of external sensor is sent to the bus after voltage recovery, as well as send the status of the actual temperature (combined).

When the work mode is “Slave”, send the status requests of these functions after voltage recovery: power on/off, the external sensor, current setpoint temperature.

	Number	Name	Object Function	Description	Group Address	Length	C	R	W	T	U	Data Type	Priority
↕	257	Floor heating	Locking function			1 bit	C	-	W	-	-	enable	Low
↕	258	Floor heating	Power on/off			1 bit	C	-	W	-	-	switch	Low
↕	259	Floor heating	External temperature sensor			2 bytes	C	-	W	T	U	temperature (°C)	Low
↕	260	Floor heating	Current temperature setpoint			2 bytes	C	-	W	-	U	temperature (°C)	Low
↕	262	Floor heating	Scene			1 byte	C	-	W	-	-	scene control	Low
↕	263	Floor heating	Power on/off, status			1 bit	C	R	-	T	-	switch	Low
↕	264	Floor heating	Actual temperature			2 bytes	C	R	-	T	-	temperature (°C)	Low
↕	265	Floor heating	Current setpoint adjustment, status			2 bytes	C	R	-	T	-	temperature (°C)	Low
↕	266	Floor heating	Heating control value			1 byte	C	-	-	T	-	percentage (0..100%)	Low

Fig.6.3.3 “Floor heating”Communication Object

NO.	Object Function	Name	Data Type	Flag	DPT
257	Locking function	Floor heating	1bit	C,W	1.003 enable
<p>The communication object is used to lock/unlock floor heating function. Telegrams:</p> <p>0—Lock</p> <p>1—Unlock</p>					
258/ 263	Power on/off	Floor heating	1bit	C,W C,T	1.001 switch
263/ 258	Power on/off, status	Floor heating	1bit	C,W,T,U/ C,R,T	1.001 switch
<p>The communication object is visible when “Via object only” or “Via both button and object” is selected.</p> <p>When the work mode is “Master” or “Single”, “Power on/off” flag is “C,W”, used to receive the telegram of power on/off; “Power on/off, status” flag is “C,R,T”, use to send the power on/off status to bus.</p>					

When the work mode is "Slave", "Power on/off" flag is "C,T", use to send the power on/off telegram to bus, to control the controller on the KNX bus; "Power on/off, status" flag is "C,W,T,U", used to receive the status of power on/off.

Telegrams:

1—On

0—Off

259	External temperature sensor	Floor heating	2byte	C,W,T,U	9.001 temperature
-----	------------------------------------	----------------------	--------------	----------------	--------------------------

The communication object is visible when "External sensor" or "Internal and External sensor combination" is selected, used to receive the room temperature from the bus, and send read request cyclically, and feedback to screen display.

260	Current temperature setpoint	Floor heating	2byte	C,W,U	9.001 temperature
-----	-------------------------------------	----------------------	--------------	--------------	--------------------------

260	Current setpoint adjustment, status	Floor heating	2byte	C,W,T,U	9.001 temperature
-----	--	----------------------	--------------	----------------	--------------------------

When the work mode is "Master", the flag is **C,W,U**, "Current temperature setpoint" is visible, used to modify the current setpoint temperature.

When the work mode is "Slave", the flag is **C,W,T,U**, "Current temperature setpoint, status" is visible, used to receive the status of current setpoint temperature, which is fed back from the controller on the bus.

While "Single", this object is not visible.

262	Scene	Floor heating	1byte	C,W	18.001 scene control
-----	--------------	----------------------	--------------	------------	-----------------------------

The communication object is visible when scene function enabled, used to recall/storage scene via bus.

When the work mode is "Slave", this object is not visible.

264	Actual temperature	Floor heating	2byte	C,R,T	9.001 temperature
-----	---------------------------	----------------------	--------------	--------------	--------------------------

The communication object is visible when "Internal and External sensor combination" is selected,

used to transmitting the actual temperature value detected by the combination temperature sensor of the device to the bus.					
265	Current temperature setpoint, status	Floor heating	2byte	C,R,T	9.001 temperature
265	Current temperature adjustment	Floor heating	2byte	C,T	9.001 temperature
<p>When the work mode is “Master”, the flag is C,R,T, “Current setpoint adjustment, status” is visible, used to feed back status of current setpoint temperature to the bus.</p> <p>When the work mode is “Slave”, the flag is C,T, “Current setpoint adjustment” is visible, used to send the current setpoint temperature to bus.</p> <p>While “Single”, this object is not visible.</p>					
266	Heating on/off Heating control value	Floor heating	1bit 1byte	C,T	1.001 switch 5.001 percentage
<p>The communication object is used to send the control value of floor heating to control the switch of floor heating valve. Telegram value is determined by temperature control type.</p> <p>1bit telegram value:</p> <p style="padding-left: 40px;">1—On</p> <p style="padding-left: 40px;">0—Off</p> <p>1byte telegram value: 0..100%</p> <p>When the work mode is “Slave”, this object is not visible.</p>					

Table6.3.3 “Floor heating”Communication Object

6.3.4. "Ventilation"Communication Object

System is no need to send a status read request when the ventilation function is voltage

recovery.

Number	Name	Object Function	Description	Group Address	Length	C	R	W	T	U	Data Type	Priority
267	Ventilation	Locking function			1 bit	C	-	W	-	-	enable	Low
268	Ventilation	Power on/off, status			1 bit	C	-	W	-	-	switch	Low
269	Ventilation	Fan speed, status			1 byte	C	-	W	-	-	percentage (0..100%)	Low
270	Ventilation	Fan automatic operation, status			1 bit	C	-	W	-	-	enable	Low
271	Ventilation	Control mode, status			1 byte	C	-	W	-	-		Low
272	Ventilation	Heat recovery on/off, status			1 bit	C	-	W	-	-	switch	Low
273	Ventilation	En./Dis. Heat recovery			1 bit	C	-	W	-	-	enable	Low
274	Ventilation	Filter timer counter change			2 bytes	C	-	W	-	-	time (h)	Low
275	Ventilation	Filter timer reset, status			1 bit	C	-	W	-	-	reset	Low
276	Ventilation	Scene			1 byte	C	-	W	-	-	scene control	Low
277	Ventilation	CO2 value			2 bytes	C	-	W	T	U	parts/million (ppm)	Low
282	Ventilation	Power on/off			1 bit	C	-	-	T	-	switch	Low
283	Ventilation	Fan speed			1 byte	C	-	-	T	-	percentage (0..100%)	Low
284	Ventilation	Fan automatic operation			1 bit	C	-	-	T	-	enable	Low
285	Ventilation	Control mode			1 byte	C	-	-	T	-		Low
286	Ventilation	Heat recovery on/off			1 bit	C	-	-	T	-	switch	Low
287	Ventilation	Filter timer counter			2 bytes	C	R	-	T	-	time (h)	Low
288	Ventilation	Filter alarm			1 bit	C	R	-	T	-	alarm	Low
289	Ventilation	Filter timer reset			1 bit	C	-	-	T	-	reset	Low
278	Ventilation	PM2.5 value			2 bytes	C	-	W	T	U	pulses	Low
279	Ventilation	VOC value			2 bytes	C	-	W	T	U	pulses	Low

Fig.6.3.4 "Ventilation"Communication Object

NO.	Object Function	Name	Data Type	Flag	DPT
267	Locking function	Ventilation	1bit	C,W	1.003 enable
<p>The communication object is used to lock/unlock ventilation function. Telegrams:</p> <p>0—Lock</p> <p>1—Unlock</p>					
268	Power on/off, status	Ventilation	1bit	C,W	1.001 switch
<p>The communication object is used to receive the power on/off telegram of ventilation from the bus. Telegrams:</p> <p>1—On</p> <p>0—Off</p>					
269	Fan speed, status	Ventilation	1byte	C,W	5.001 percentage 5.100 fan stage
<p>The communication object is used to receive the current fan speed from the bus. Telegram value is</p>					

determined by parameter setting datatype.					
270	Fan automatic operation, status	Ventilation	1bit	C,W	1.003 enable
<p>The communication object is used to receive feedback status of fan automatic operation from the bus.</p> <p>Telegrams:</p> <p>1—Automatic</p> <p>0—Cancel automatic</p>					
271	Control mode, status	Ventilation	1byte	C,W	
<p>The communication object is visible when mode function enabled, used to receive feedback status of control mode from the bus.</p>					
272	Heat recovery on/off, status	Ventilation	1bit	C,W	1.001 switch
<p>The communication object is used to receive feedback status of heat recovery on/off from the bus.</p> <p>Telegrams:</p> <p>1—Active</p> <p>0—Inactiv</p>					
273	En./Dis. Heat recovery	Ventilation	1bit	C,W	1.003 enable
<p>The communication object is used to disable/enable heat recovery via the bus.</p>					
274	Filter timer counter change	Ventilation	2byte	C,W	7.007 time(h)
<p>The communication object is visible when filter timer counter function enabled, used to modify the time length of the filter usage by the bus, the unit is in hours.</p>					
275	Filter timer reset, status	Ventilation	1bit	C,W	1.015 reset
<p>The communication object is visible when filter timer counter function enabled, used to reset the filter time via the bus, and after the filter is reset, the filter time is used to start counting again.</p> <p>Telegram value:</p> <p>1—Reset</p>					
276	Scene	Ventilation	1byte	C,W	18.001 scene control
<p>The communication object is visible when scene function enabled, used to recall/storage scene via</p>					

bus.					
277	CO2 value	Ventilation	2byte	C,W,T,U	7.001 pulse 9.008 parts/million(ppm)
278	PM 2.5 value	Ventilation	2byte	C,W,T,U	7.001 pulse 9.030 concentration(ug/m3)
279	VOC value	Ventilation	2byte	C,W,T,U	7.001 pulse 9.030 concentration(ug/m3)
<p>These communication objects are used to receive the input of the PM2.5/VOC/CO2 value and get the corresponding value from the bus to be updated to the display in ug/m³ or ppm. Range:0~999ug/m³ or 0~4000ppm</p> <p>If the control value of the automatic operation is PM2.5, the ventilation system can be set to automatically adjust the fan speed according to the concentration of PM2.5.</p>					
282	Power on/off	Ventilation	1bit	C,T	1.001 switch
<p>The communication object is used to send the power on/off telegram of ventilation, to control ventilation power on/off on the KNX bus. Cancel Auto function at the same time after power-off.</p>					
283	Fan speed	Ventilation	1byte	C,T	5.001 percentage 5.100 fan stage
<p>The communication object is used to control fan speed via the screen, and send control telegram of each fan speed to the bus. Telegram value is determined by parameter setting datatype.</p>					
284	Fan automatic operation	Ventilation	1bit	C,T	1.003 enable
<p>The communication object is visible when automatic operation function enabled, used to send control telegram of fan automatic operation to the bus. Telegrams:</p> <p>1—Automatic</p> <p>0—Cancel automatic</p>					
285	Control mode	Ventilation	1byte	C,T	
<p>The communication object is visible when mode function enabled, used to send control telegram</p>					

of control mode to the bus.					
286	Heat recovery on/off	Ventilation	1bit	C,T	1.001 switch
<p>The communication object is visible when heat recovery function enabled, used to send telegram of heat recovery on/off to the bus. Telegrams:</p> <p style="padding-left: 40px;">1—Active</p> <p style="padding-left: 40px;">0—Inactive</p>					
287	Filter timer counter	Ventilation	2byte	C,R,T	7.007 time(h)
<p>The communication object is visible when filter time counter function enabled, used to count the length of the filter, send telegram to the bus when the count value changes. The unit of filter time counter is in hours.</p>					
288	Filter alarm	Ventilation	1bit	C,T	1.005 alarm
<p>The communication object is visible when filter time counter function enabled, used for longer than the set value, the communication object sends an alarm to remind the user to replace the filter.</p> <p>Telegram value:</p> <p style="padding-left: 40px;">1—Alarm</p>					
289	Filter timer reset	Ventilation	1bit	C,T	1.015 reset
<p>The communication object is visible when filter time counter function enabled, used to send the filter timer reset status to the bus, and you can also long press button 1s to reset.</p>					

Table6.3.4 "Ventilation"Communication Object

6.3.5. "Audio" Communication Object

When status read request is enabled, and power on/off is disabled, system needs to return to the status as before voltage failure when voltage recovery, and need to send these status requests when restarted: play status, play mode, volume percent, mute, track name, album name, artist name (related function is enabled); When power on/off is enabled, the sending requests are the same with the disabled, but note that status of power on/off is no need to send.

Number	Name	Object Function	Description	Group Address	Length	C	R	W	T	U	Data Type	Priority
290	Audio	Locking function			1 bit	C	-	W	-	-	enable	Low
291	Audio	Power on/off, status			1 bit	C	-	W	-	-	switch	Low
292	Audio	Play, status			1 bit	C	-	W	T	U	enable	Low
293	Audio	Pause, status			1 bit	C	-	W	T	U	enable	Low
294	Audio	Volume, status			1 byte	C	-	W	T	U	percentage (0..100%)	Low
295	Audio	Mute, status			1 bit	C	-	W	T	U	enable	Low
296	Audio	Play mode, status			1 byte	C	-	W	T	U		Low
297	Audio	Track name			14 bytes	C	-	W	T	U	Character String (ISO 8859-1)	Low
298	Audio	Album name			14 bytes	C	-	W	T	U	Character String (ISO 8859-1)	Low
299	Audio	Artist name			14 bytes	C	-	W	T	U	Character String (ISO 8859-1)	Low
300	Audio	Power on/off			1 bit	C	-	-	T	-	switch	Low
301	Audio	Play			1 bit	C	-	-	T	-	enable	Low
302	Audio	Pause			1 bit	C	-	-	T	-	enable	Low
303	Audio	Next track			1 bit	C	-	-	T	-	enable	Low
304	Audio	Previous track			1 bit	C	-	-	T	-	enable	Low
305	Audio	Volume+=1/Volume-=0			1 bit	C	-	-	T	-	step	Low
306	Audio	Relative volume adjustment			4 bit	C	-	-	T	-	dimming control	Low
308	Audio	Mute			1 bit	C	-	-	T	-	enable	Low
309	Audio	Play mode			1 byte	C	-	-	T	-		Low
307	Audio	Absolute volume adjustment			1 byte	C	-	-	T	-	percentage (0..100%)	Low

Fig.6.3.5 "Audio" Communication Object

NO.	Object Function	Name	Data Type	Flag	DPT
290	Locking function	Audio	1bit	C,W	1.003 enable
<p>The communication object is used to lock/unlock audio control function. Telegrams:</p> <p style="text-align: center;">0—Lock</p> <p style="text-align: center;">1—Unlock</p>					
291	Power on/off, status	Audio	1bit	C,W,	1.001 switch
<p>The communication object is visible when power on/off is enabled, used to receive the status feedback of on/off in audio module from bus, and feed back to screen display.</p>					
292	Play=1/Pause=0, status	Audio	1bit	C,W,T,U	1.010 start/stop
<p>The communication object is visible when control play/pause with one object, used to receive the status feedback of play/pause in audio module from bus, and feed back to screen display.</p>					

292	Play, status	Audio	1bit	C,W,T,U	1.003 enable
<p>The communication object is visible when control play/pause with two separate objects, used to receive the status feedback of play in audio module from bus, and feed back to screen display.</p> <p>Telegram 1 is to play, 0 is meaningless.</p>					
293	Pause, status	Audio	1bit	C,W,T,U	1.003 enable
<p>The communication object is visible when control play/pause with two separate objects, used to receive the status feedback of pause in audio module from bus, and feed back to screen display.</p> <p>Telegram 1 is to stop, 0 is meaningless.</p>					
294	Volume, status	Audio	1byte	C,W,T,U	5.001 percentage 5.004 percentage
<p>The communication object is visible when parameter "Volume adjustment via long operation" is not selected "Disable", used to receive the volume status in audio module, and feed back to screen display. Telegrams value is according to different object types: 0..100 / 0..255</p>					
295	Mute, status	Audio	1bit	C,W,T,U	1.003 enable
<p>The communication object is visible when mute is enabled, used to receive the mute status of the audio module from the bus, and feed back to screen display.</p>					
296	Play mode, status	Audio	1byte	C,W,T,U	
<p>The communication object is visible when play mode is enabled, used to receive the status feedback of play mode in the audio module, the receiving telegrams should be preset by parameters before the display status on the screen can be updated.</p>					
297	Track name	Audio	14byte	C,W,T,U	16.001 character string (ISO 8859-1)
<p>The communication object is visible when track name is enabled, used to receive the track name via the bus, and display on the screen.</p>					
298	Album name	Audio	14byte	C,W,T,U	16.001 character string (ISO 8859-1)
<p>The communication object is visible when album name is enabled, used to receive the album name via the bus, and display on the screen.</p>					

299	Artist name	Audio	14byte	C,W,T,U	16.001 character string (ISO 8859-1)
<p>The communication object is visible when artist name is enabled, used to receive the artist name via the bus, and display on the screen.</p>					
300	Power on/off	Audio	1bit	C,T	1.001 switch
<p>The communication object is visible when power on/off is enabled, used to send the telegram to the bus. Telegrams:</p> <p style="text-align: center;">1---On</p> <p style="text-align: center;">0---Off</p>					
301	Play=1/Pause=0 Play	Audio	1bit	C,T	1.010 start/stop
<p>The communication object is visible when control play/pause with one object, used to play/stop the music in the audio module. Telegrams:</p> <p style="text-align: center;">1---Play</p> <p style="text-align: center;">0---Pause</p>					
301	Play	Audio	1bit	C,T	1.003 enable
<p>The communication object is visible when control play/pause with two separate objects, used to play the music in the audio module. Telegram 1 is to play, 0 is meaningless.</p>					
302	Pause	Audio	1bit	C,T	1.003 enable
<p>The communication object is visible when control play/pause with two separate objects, used to stop the music in the audio module. Telegram 1 is to stop, 0 is meaningless.</p>					
303	Next track=1/Previous track=0	Audio	1bit	C,T	1.007 step
<p>The communication object is visible when control next track/previous track with one object, used to switch the playing song of the audio module, to switch the previous song/the next song. Telegrams:</p> <p style="text-align: center;">1---Next track</p> <p style="text-align: center;">0---Previous track</p>					

303	Next track	Audio	1bit	C,T	1.003 enable
<p>The communication object is visible when control next track/previous track with two separate objects, used to switch the playing song of the audio module, to switch the next song. Telegram 1 is to play next song, 0 is meaningless.</p>					
304	Previous track	Audio	1bit	C,T	1.003 enable
<p>The communication object is visible when control next track/previous track with two separate objects, used to switch the playing song of the audio module, to switch the previous song. Telegram 1 is play the previous song, 0 is meaningless.</p>					
305	Volume+=1/Volume-=0	Audio	1bit	C,T	1.007 step
<p>The communication object is used to adjust the volume in audio module when short operation.</p> <p>Telegrams:</p> <p style="margin-left: 40px;">1—Increase volume</p> <p style="margin-left: 40px;">0—Decrease volume</p>					
306	Relative volume adjustment	Audio	4bit	C,T	3.007 dimming
<p>The communication object is visible when relative adjustment, used to adjust the volume in audio module when long operation, step value is determined by the parameter.</p>					
307	Absolute volume adjustment	Audio	1byte	C,T	5.001 percentage 5.004 percentage
<p>The communication object is visible when absolute adjustment, used to adjust the volume in audio module when long operation, step value is determined by the parameter.</p> <p>Telegram is determined by different object datatype: 0..100 / 0..255</p>					
308	Mute	Audio	1bit	C,T	1.003 enable
<p>The communication object is visible when mute is enabled, used to control mute of audio module via the button. Telegrams:</p> <p style="margin-left: 40px;">1—Mute</p> <p style="margin-left: 40px;">0—Cancel mute</p>					

309	Play mode	Audio	1byte	C,T	5.010 counter pulses
The communication object is visible when play mode is enabled, used to send control telegram of the audio module play mode, different mode telegrams are preset by parameters.					

Table6.3.5 "Audio"Communication Object

6.4. "Logic"Communication Object

6.4.1. "AND/OR/XOR"Communication Object

	Number	Name	Object Function	Description	Group Address	Length	C	R	W	T	U	Data Type	Priority
➡	11	1st Logic-...	Input a			1 bit	C	-	W	T	U	boolean	Low
➡	12	1st Logic-...	Input b			1 bit	C	-	W	T	U	boolean	Low
➡	13	1st Logic-...	Input c			1 bit	C	-	W	T	U	boolean	Low
➡	14	1st Logic-...	Input d			1 bit	C	-	W	T	U	boolean	Low
➡	15	1st Logic-...	Input e			1 bit	C	-	W	T	U	boolean	Low
➡	16	1st Logic-...	Input f			1 bit	C	-	W	T	U	boolean	Low
➡	17	1st Logic-...	Input g			1 bit	C	-	W	T	U	boolean	Low
➡	18	1st Logic-...	Input h			1 bit	C	-	W	T	U	boolean	Low
➡	19	1st Logic-...	Logic result			1 bit	C	-	-	T	-	boolean	Low

Fig.6.4.1 "AND/OR/XOR"Communication Object

NO.	Object Function	Name	Data Type	Flag	DPT
11/.../18	Input x	1st Logic- {{...}}	1bit	C,W,T,U	1.002 boolean
<p>The communication object is used to receive the value of logical input Input x.</p> <p>The name in parentheses changes with the parameter "Description for logic function". If description is empty, display "1st Logic" by default. The same below.</p>					
19	Logic result	1st Logic- {{...}}	1bit	C,T	1.002 boolean
<p>The communication object is used to send the results of logical operation.</p>					

Table6.4.1 "AND/OR/XOR"Communication Object

6.4.2. "Gate forwarding"Communication Object

Number	Name	Object Function	Description	Group Address	Length	C	R	W	T	U	Data Type	Priority
11	1st Logic-...	Gate value select			1 byte	C	-	W	-	-	scene number	Low
12	1st Logic-...	Input A			1 bit	C	-	W	-	-	switch	Low
13	1st Logic-...	Input B			1 bit	C	-	W	-	-	switch	Low
14	1st Logic-...	Input C			1 bit	C	-	W	-	-	switch	Low
15	1st Logic-...	Input D			1 bit	C	-	W	-	-	switch	Low
16	1st Logic-...	Output A			1 bit	C	-	-	T	-	switch	Low
17	1st Logic-...	Output B			1 bit	C	-	-	T	-	switch	Low
18	1st Logic-...	Output C			1 bit	C	-	-	T	-	switch	Low
19	1st Logic-...	Output D			1 bit	C	-	-	T	-	switch	Low

Fig.6.4.2 "Gate forwarding"Communication Object

NO.	Object Function	Name	Data Type	Flag	DPT
11	Gate value select	1st Logic- {...}	1byte	C,W	17.001 scene number
The communication object is used to select the scene of logical gate forwarding.					
12/.../15	Input x	1st Logic- {...}	1bit 4bit 1byte	C,W	1.001 switch 3.007 dimming control 5.010 counter pulses(0..255)
The communication object is used to receive the value of the logic gate input Input x.					
16/.../19	Output x	1st Logic- {...}	1bit 4bit 1byte	C,T	1.001 switch 3.007 dimming control 5.010 counter pulses(0..255)
The communication object is used to output the value forwarded by the logic gate. The output value is the same as the input value, but one input can be forwarded into one or more outputs, set by parameters.					

Table6.4.2 "Gate forwarding"Communication Object

6.4.3. "Threshold comparator"Communication Object

	Number	Name	Object Function	Description	Group Address	Length	C	R	W	T	U	Data Type	Priority
↔	11	1st Logic-...	Threshold value input			4 bit	C	-	W	-	U	dimming control	Low
↔	19	1st Logic-...	Logic result			1 bit	C	-	-	T	-	boolean	Low

	Number	Name	Object Function	Description	Group Address	Length	C	R	W	T	U	Data Type	Priority
↔	11	1st Logic-...	Threshold value input			1 byte	C	-	W	-	U	counter pulses (0..255)	Low
↔	19	1st Logic-...	Logic result			1 bit	C	-	-	T	-	boolean	Low

	Number	Name	Object Function	Description	Group Address	Length	C	R	W	T	U	Data Type	Priority
↔	11	1st Logic-...	Threshold value input			2 bytes	C	-	W	-	U	pulses	Low
↔	19	1st Logic-...	Logic result			1 bit	C	-	-	T	-	boolean	Low

	Number	Name	Object Function	Description	Group Address	Length	C	R	W	T	U	Data Type	Priority
↔	11	1st Logic-...	Threshold value input			2 bytes	C	-	W	-	U	2-byte signed value	Low
↔	19	1st Logic-...	Logic result			1 bit	C	-	-	T	-	boolean	Low

	Number	Name	Object Function	Description	Group Address	Length	C	R	W	T	U	Data Type	Priority
↔	11	1st Logic-...	Threshold value input			2 bytes	C	-	W	-	U	2-byte float value	Low
↔	19	1st Logic-...	Logic result			1 bit	C	-	-	T	-	boolean	Low

	Number	Name	Object Function	Description	Group Address	Length	C	R	W	T	U	Data Type	Priority
↔	11	1st Logic-...	Threshold value input			4 bytes	C	-	W	-	U	counter pulses (unsigned)	Low
↔	19	1st Logic-...	Logic result			1 bit	C	-	-	T	-	boolean	Low

	Number	Name	Object Function	Description	Group Address	Length	C	R	W	T	U	Data Type	Priority
↔	11	1st Logic-...	Threshold value input			2 bytes	C	-	W	-	U	temperature (°C)	Low
↔	19	1st Logic-...	Logic result			1 bit	C	-	-	T	-	boolean	Low

	Number	Name	Object Function	Description	Group Address	Length	C	R	W	T	U	Data Type	Priority
↔	11	1st Logic-...	Threshold value input			2 bytes	C	-	W	-	U	humidity (%)	Low
↔	19	1st Logic-...	Logic result			1 bit	C	-	-	T	-	boolean	Low

	Number	Name	Object Function	Description	Group Address	Length	C	R	W	T	U	Data Type	Priority
↔	11	1st Logic-...	Threshold value input			2 bytes	C	-	W	-	U	lux (Lux)	Low
↔	19	1st Logic-...	Logic result			1 bit	C	-	-	T	-	boolean	Low

Fig.6.4.3 "Threshold comparator"Communication Object

NO.	Object Function	Name	Data Type	Flag	DPT
11	Threshold value input	1st Logic- {{...}}	4bit 1byte 2byte 4byte	C,W, U	3.007 dimming 5.010 counter pulses 7.001 pulses 12.001 counter pulses 8.x signed value 9.x float value 9.001 temperature 9.007 humidity 9.004 lux
The communication object is used to input threshold value.					
19	Logic result	1st Logic- {{...}}	1bit	C,T	1.002 boolean
The communication object is used to send the results of logical operation. That is, the value that should be sent after the object input threshold is compared with the setting threshold value.					

Table6.4.3 "Threshold comparator"Communication Object

6.4.4. "Format convert" Communication Object

	Number	Name	Object Function	Description	Group Address	Length	C	R	W	T	U	Data Type	Priority
↔	11	1st Logic-...	Input 1bit-bit0			1 bit	C	-	W	-	U	boolean	Low
↔	12	1st Logic-...	Input 1bit-bit1			1 bit	C	-	W	-	U	boolean	Low
↔	19	1st Logic-...	Output 2bit			2 bit	C	-	-	T	-	switch control	Low

"2x1bit --> 1x2bit"function: converts two 1bit values to a 2bit value, such as Input bit1=1, bit0=0--> Output 2bit=2

	Number	Name	Object Function	Description	Group Address	Length	C	R	W	T	U	Data Type	Priority
↔	11	1st Logic-...	Input 1bit-bit0			1 bit	C	-	W	-	U	boolean	Low
↔	12	1st Logic-...	Input 1bit-bit1			1 bit	C	-	W	-	U	boolean	Low
↔	13	1st Logic-...	Input 1bit-bit2			1 bit	C	-	W	-	U	boolean	Low
↔	14	1st Logic-...	Input 1bit-bit3			1 bit	C	-	W	-	U	boolean	Low
↔	15	1st Logic-...	Input 1bit-bit4			1 bit	C	-	W	-	U	boolean	Low
↔	16	1st Logic-...	Input 1bit-bit5			1 bit	C	-	W	-	U	boolean	Low
↔	17	1st Logic-...	Input 1bit-bit6			1 bit	C	-	W	-	U	boolean	Low
↔	18	1st Logic-...	Input 1bit-bit7			1 bit	C	-	W	-	U	boolean	Low
↔	19	1st Logic-...	Output 1byte			1 byte	C	-	-	T	-	counter pulses (0..255)	Low

"8x1bit --> 1x1byte"function: converts eight 1bit values to a 1byte value, such as Input bit2=1, bit1=1, bit0=1,other bits are 0--> Output 1byte=7

	Number	Name	Object Function	Description	Group Address	Length	C	R	W	T	U	Data Type	Priority
↔	11	1st Logic-...	Input 1byte			1 byte	C	-	W	-	U	counter pulses (0..255)	Low
↔	19	1st Logic-...	Output 2byte			2 bytes	C	-	-	T	-	pulses	Low

"1x1byte --> 1x2byte"function: converts one 1byte values to a 2byte value, such as Input 1byte=125--> Output 2byte=125.Although the value remains the same, the data type of the value is different.

	Number	Name	Object Function	Description	Group Address	Length	C	R	W	T	U	Data Type	Priority
↔	11	1st Logic-...	Input 1byte-low			1 byte	C	-	W	-	U	counter pulses (0..255)	Low
↔	12	1st Logic-...	Input 1byte-high			1 byte	C	-	W	-	U	counter pulses (0..255)	Low
↔	19	1st Logic-...	Output 2byte			2 bytes	C	-	-	T	-	pulses	Low

"2x1byte --> 1x2byte"function: converts two 1byte values to a 2byte value, such as Input 1byte-low = 255 (\$FF), Input 1byte-high = 100 (\$64) --> Output 2byte = 25855 (\$64 FF)

	Number	Name	Object Function	Description	Group Address	Length	C	R	W	T	U	Data Type	Priority
↔	11	1st Logic-...	Input 2byte-low			2 bytes	C	-	W	-	U	pulses	Low
↔	12	1st Logic-...	Input 2byte-high			2 bytes	C	-	W	-	U	pulses	Low
↔	19	1st Logic-...	Output 4byte			4 bytes	C	-	-	T	-	counter pulses (unsigned)	Low

"2x2byte --> 1x4byte"function: converts two 2 byte values to a 4byte value, such as Input 2byte-low = 65530 (\$FF FA), Input 2byte-high = 32768 (\$80 00)--> Output 2byte = 2147549178 (\$80 00 FF FA)

	Number	Name	Object Function	Description	Group Address	Length	C	R	W	T	U	Data Type	Priority
↔	11	1st Logic-...	Input 1byte			1 byte	C	-	W	-	U	counter pulses (0..255)	Low
↔	12	1st Logic-...	Output 1bit-bit0			1 bit	C	-	-	T	-	boolean	Low
↔	13	1st Logic-...	Output 1bit-bit1			1 bit	C	-	-	T	-	boolean	Low
↔	14	1st Logic-...	Output 1bit-bit2			1 bit	C	-	-	T	-	boolean	Low
↔	15	1st Logic-...	Output 1bit-bit3			1 bit	C	-	-	T	-	boolean	Low
↔	16	1st Logic-...	Output 1bit-bit4			1 bit	C	-	-	T	-	boolean	Low
↔	17	1st Logic-...	Output 1bit-bit5			1 bit	C	-	-	T	-	boolean	Low
↔	18	1st Logic-...	Output 1bit-bit6			1 bit	C	-	-	T	-	boolean	Low
↔	19	1st Logic-...	Output 1bit-bit7			1 bit	C	-	-	T	-	boolean	Low

“1x1byte --> 8x1bit” function: converts one 1byte values to eight 1bit value, such as Input 1byte=200 --> Output bit0=0, bit1=0, bit2=0, bit3=1, bit4=0, bit5=0, bit6=1, bit7=1

	Number	Name	Object Function	Description	Group Address	Length	C	R	W	T	U	Data Type	Priority
↔	11	1st Logic-...	Input 2byte			2 bytes	C	-	W	-	U	pulses	Low
↔	18	1st Logic-...	Output 1byte-low			1 byte	C	-	-	T	-	counter pulses (0..255)	Low
↔	19	1st Logic-...	Output 1byte-high			1 byte	C	-	-	T	-	counter pulses (0..255)	Low

“1x2byte --> 2x1byte”function: converts one 2byte values to two 1byte value, such as Input 2byte = 55500 (\$D8 CC) --> Output 1byte-low = 204 (\$CC), Output 1byte-high =216 (\$D8)

	Number	Name	Object Function	Description	Group Address	Length	C	R	W	T	U	Data Type	Priority
↔	11	1st Logic-...	Input 4byte			4 bytes	C	-	W	-	U	counter pulses (unsigned)	Low
↔	18	1st Logic-...	Output 2byte-low			2 bytes	C	-	-	T	-	pulses	Low
↔	19	1st Logic-...	Output 2byte-high			2 bytes	C	-	-	T	-	pulses	Low

“1x4byte --> 2x2byte”function: converts one 4byte values to two 2byte value, such as Input 4byte = 78009500 (\$04 A6 54 9C) --> Output 2byte-low = 21660 (\$54 9C), Output 2byte-high =1190 (\$04 A6)

	Number	Name	Object Function	Description	Group Address	Length	C	R	W	T	U	Data Type	Priority
↔	11	1st Logic-...	Input 3byte			3 bytes	C	-	W	-	U	RGB value 3x(0..255)	Low
↔	17	1st Logic-...	Output 1byte-low			1 byte	C	-	-	T	-	counter pulses (0..255)	Low
↔	18	1st Logic-...	Output 1byte-middle			1 byte	C	-	-	T	-	counter pulses (0..255)	Low
↔	19	1st Logic-...	Output 1byte-high			1 byte	C	-	-	T	-	counter pulses (0..255)	Low

“1x3byte --> 3x1byte”function: converts one 3byte values to three 1byte value, such as Input 3byte = \$78 64 C8--> Output 1byte-low = 200 (\$C8) , Output 1byte-middle = 100 (\$64) , Output 1byte-high =120 (\$78)

	Number	Name	Object Function	Description	Group Address	Length	C	R	W	T	U	Data Type	Priority
↔	11	1st Logic-...	Input 1byte-low			1 byte	C	-	W	-	U	counter pulses (0..255)	Low
↔	12	1st Logic-...	Input 1byte-middle			1 byte	C	-	W	-	U	counter pulses (0..255)	Low
↔	13	1st Logic-...	Input 1byte-high			1 byte	C	-	W	-	U	counter pulses (0..255)	Low
↔	19	1st Logic-...	Output 3byte			3 bytes	C	-	-	T	-	RGB value 3x(0..255)	Low

“3x1byte --> 1x3byte”function: converts three 1byte values to a 3byte value, such as Input 1byte-low = 150 (\$96), Input 1byte-middle = 100 (\$64), Input 1byte-high = 50 (\$32)--> Output 3byte = \$32 64 96

Fig.6.4.4 “Format convert”Communication Object

NO.	Object Function	Name	Data Type	Flag	DPT
11	Input ...	1st Logic- {{...}}	1bit	C,W,U	1.001 switch
			1byte		5.010 counter pulses(0..255)
			2byte		7.001 pulses
			3byte		232.600 RGB value 3x(0..255)
			4byte		12.001 counter pulses
The communication object is used to input a value that needs to be converted.					
19	Output ...	1st Logic- {{...}}	1bit	C,T	1.001 switch
			2bit		2.001 switch control
			1byte		5.010 counter pulses(0..255)
			2byte		7.001 pulses
			3byte		232.600 RGB value 3x(0..255)
4byte	12.001 counter pulses				
The communication object is used to output the converted value.					

Table6.4.4 "Format convert"Communication Object

6.4.5. "Gate function"Communication Object

	Number	Name	Object Function	Description	Group Address	Length	C	R	W	T	U	Data Type	Priority
↔	11	1st Logic-...	Input			1 bit	C	-	W	-	-	switch	Low
↔	12	1st Logic-...	Gate input			1 bit	C	-	W	-	-	boolean	Low
↔	19	1st Logic-...	Output			1 bit	C	-	-	T	-	switch	Low

Input/Output - 1bit[On/Off]

	Number	Name	Object Function	Description	Group Address	Length	C	R	W	T	U	Data Type	Priority
↔	11	1st Logic-...	Input			1 byte	C	-	W	-	-	percentage (0..100%)	Low
↔	12	1st Logic-...	Gate input			1 bit	C	-	W	-	-	boolean	Low
↔	19	1st Logic-...	Output			1 byte	C	-	-	T	-	percentage (0..100%)	Low

Input/Output - 1byte[0..100%]

	Number	Name	Object Function	Description	Group Address	Length	C	R	W	T	U	Data Type	Priority
↔	11	1st Logic-...	Input			1 byte	C	-	W	-	-	counter pulses (0..255)	Low
↔	12	1st Logic-...	Gate input			1 bit	C	-	W	-	-	boolean	Low
↔	19	1st Logic-...	Output			1 byte	C	-	-	T	-	counter pulses (0..255)	Low

Input/Output - 1byte[0..255]

	Number	Name	Object Function	Description	Group Address	Length	C	R	W	T	U	Data Type	Priority
↔	11	1st Logic-...	Input			2 bytes	C	-	W	-	-	temperature (°C)	Low
↔	12	1st Logic-...	Gate input			1 bit	C	-	W	-	-	boolean	Low
↔	19	1st Logic-...	Output			2 bytes	C	-	-	T	-	temperature (°C)	Low

Input/Output - 2byte[Float]

	Number	Name	Object Function	Description	Group Address	Length	C	R	W	T	U	Data Type	Priority
↔	11	1st Logic-...	Input			2 bytes	C	-	W	-	-	pulses	Low
↔	12	1st Logic-...	Gate input			1 bit	C	-	W	-	-	boolean	Low
↔	19	1st Logic-...	Output			2 bytes	C	-	-	T	-	pulses	Low

Input/Output - 2byte[0..65535]

Fig.6.4.5 "Gate function"Communication Object

NO.	Object Function	Name	Data Type	Flag	DPT
11	Input	1st Logic- {{...}}	1bit	C,W	1.001 switch
			1byte		5.001 percentage
			2byte		5.010 counter pulses
			2byte		9.001 temperature
					7.001 pulses
The communication object is used to input a value that needs to gate filter.					
12	Gate input	1st Logic- {{...}}	1bit	C,W	1.002 boolean
The communication object is used to control the switch status of gate input. Input signal is allowed to pass when gate open, then output, and the current input status is still sent if there is a change; Can not pass when gate close.					
19	Output	1st Logic- {{...}}	bit	C,T	1.001 switch
			1byte		5.001 percentage
			2byte		5.010 counter pulses

					9.001 temperature 7.001 pulses
<p>The communication object is used to output the value after gate filtering. Only when gate input status is open, output is available, defined by the object "Gate input".</p>					

Table6.4.5 "Gate function"Communication Object

6.4.6. "Delay function"Communication Object

Number	Name	Object Function	Description	Group Address	Length	C	R	W	T	U	Data Type	Priority
11	1st Logic-...	Input			1 bit	C	-	W	-	-	switch	Low
19	1st Logic-...	Output			1 bit	C	-	-	T	-	switch	Low
Input/Output - 1bit[On/Off]												
11	1st Logic-...	Input			1 byte	C	-	W	-	-	percentage (0..100%)	Low
19	1st Logic-...	Output			1 byte	C	-	-	T	-	percentage (0..100%)	Low
Input/Output - 1byte[0..100%]												
11	1st Logic-...	Input			1 byte	C	-	W	-	-	counter pulses (0..255)	Low
19	1st Logic-...	Output			1 byte	C	-	-	T	-	counter pulses (0..255)	Low
Input/Output - 1byte[0..255]												
11	1st Logic-...	Input			2 bytes	C	-	W	-	-	temperature (°C)	Low
19	1st Logic-...	Output			2 bytes	C	-	-	T	-	temperature (°C)	Low
Input/Output - 2byte[Float]												
11	1st Logic-...	Input			2 bytes	C	-	W	-	-	pulses	Low
19	1st Logic-...	Output			2 bytes	C	-	-	T	-	pulses	Low
Input/Output - 2byte[0..65535]												

Fig.6.4.6 "Delay function"Communication Object

NO.	Object Function	Name	Data Type	Flag	DPT
11	Input	1st Logic- {{...}}	1bit	C,W	1.001 switch
			1byte		5.001 percentage
			2byte		5.010 counter pulses
			2byte		9.001 temperature
			2byte		7.001 pulses
The communication object is used to input a value that needs to delay.					
19	Output	1st Logic- {{...}}	1bit	C,T	1.001 switch
			1byte		5.001 percentage
			2byte		5.010 counter pulses
			2byte		9.001 temperature
			2byte		7.001 pulses
The communication object is used to output that needs to delay converted value, delay time is defined by the parameter.					

Table6.4.6 "Delay function"Communication Object

6.4.7. "Staircase lighting"Communication Object

	Number	Name	Object Function	Description	Group Address	Length	C	R	W	T	U	Data Type	Priority
↕	11	1st Logic-...	Trigger value			1 bit	C	-	W	-	-	trigger	Low
↕	12	1st Logic-...	Light-on duration time			2 bytes	C	-	W	-	-	time (s)	Low
↕	19	1st Logic-...	Output			1 bit	C	-	-	T	-	switch	Low

1 bit

	Number	Name	Object Function	Description	Group Address	Length	C	R	W	T	U	Data Type	Priority
↕	11	1st Logic-...	Trigger value			1 bit	C	-	W	-	-	trigger	Low
↕	12	1st Logic-...	Light-on duration time			2 bytes	C	-	W	-	-	time (s)	Low
↕	19	1st Logic-...	Output			1 byte	C	-	-	T	-	counter pulses (0..255)	Low

1byte

Fig.6.4.7 "Staircase lighting"Communication Object

NO.	Object Function	Name	Data Type	Flag	DPT
11	Trigger value	1st Logic- {...}	1bit	C,W	1.017 trigger
The communication object is used to receive the value to trigger staircase lighting.					
12	Light-on duration time	1st Logic- {...}	2byte	C,W	7.005 time(s)
The communication object is used to modify the staircase light-on duration time, the modified range is referenced from the range defined by the parameter, take the limit value if exceeded.					
19	Output	1st Logic- {...}	1bit 1byte	C,T	1.001 switch 5.010 counter pulses
The communication object is used to output value 1 when trigger, and send value 2 after duration time. Telegram value is determined by the parameter setting datatype.					

Table6.4.7 "Staircase lighting"Communication Object

6.5. "Scene Group"Communication Object











Number	Name	Object Function	Description	Group Address	Length	C	R	W	T	U	Data Type	Priority
83	Scene Group	Main scene trigger			1 byte	C	-	W	-	-	scene number	Low
84	1st Scene Group-Output 1-...	1bit value			1 bit	C	-	-	T	-	switch	Low



Fig.6.5 "Scene Group"Communication Object













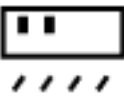









NO.	Object Function	Name	Data Type	Flag	DPT
83	Main scene trigger	Scene Group	1byte	C,W	17.001 scene number
<p>This communication object triggers each output in the scene group to send a specific value to the bus by recalling the scene number. Telegrams: 0.. 63</p>					
84	1bit value 1byte unsigned value HVAC mode 2byte unsigned value Temperature	1st Scene Group-{{Output x}}	1bit 1byte 2byte	C,T	1.001 switch 5.010 counter pulses 20.102 HVAC mode 7.001 pulses 9.001 temperature
<p>When a scene is recalled, the communication object is used to send the corresponding output value of the scene to the bus. If the output is not set to this scene, it will not be sent.</p> <p>A total of 8 scene groups can be set up, with 8 outputs per group.</p> <p>The name in parentheses changes with the parameter "Description for logic function". If description is empty, display "1st Scene Group-Output x" by default. The same below.</p>					









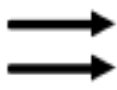
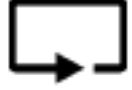









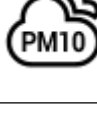

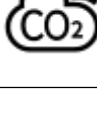

Table6.5 "Scene Group"Communication Object



Chapter 7 Icon list

ETS options	Icon
Brighter	
Go home 1	
Go home 2	
Welcome	
Dinner	
Sleeping	
Media	
Comfort	
Economy	
Wake up	

ETS options	Icon
Darker	
Leave home 1	
Leave home 2	
Meeting(guest)	
Party	
Reading	
Cleaning	
Standby	
Protection	
TV	

Fan		Heating/Cooling system	
Air conditioner 1		Air conditioner 2	
Floor heating		Water heating	
Ventilation system		Mode	
Auto mode		Heating mode	
Cooling mode		Fan mode	
Dehumidification mode		Refresh mode	
Sleep mode		Wind direction	
Fan speed		Fan speed off	
Fan speed 1		Fan speed 2	
Fan speed 3		Fan speed 4	
Fan speed 5		Fan speed auto	

Music		Play	
Pause		Volume +	
Volume -		Previous track	
Next track		Random playback	
Sequential playback		Repeat playlist	
Playlist		Unlock	
Lock		Unmute	
Mute		Day	
Night		Setting	
Room temperature		PM2.5	
PM10		TVOC/VOC	
CO2		Temperature	

Humidity		Brightness	
Windspeed		Rain	