

FEATURES

- KNX RF (RF1.R @ 868.3 MHz) device for motion detection
- Motion detection through PIR technology
- Available in the following colors: gloss white (RAL 9003) and anthracite black (RAL 9004)
- Tamper contact with parameterizable sendings
- Detection range of up to Ø 6 m
- HVAC-control dedicated detection
- Low-battery warning functionality
- External dimensions: Ø 58.0 x 41.0 mm
- Internal dimensions: Ø 48.3 x 41.0 mm
- Cutting diameter (hole saw blade): Ø 51 mm
- False-ceiling flush-mounted
- Conformity with the CE, UKCA, RCM directives (marks on the back side)

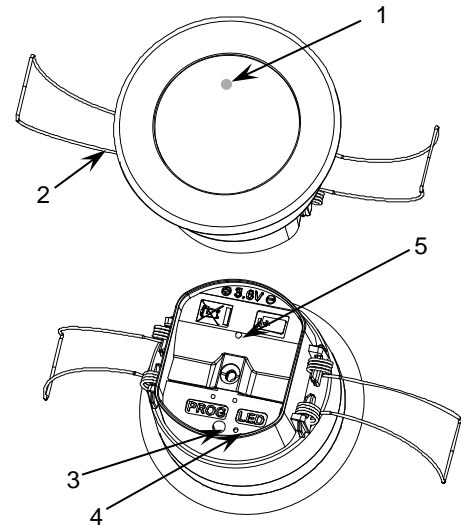

Figure 1: EyeZen RF 868

1. Detection LED indicator 2. Retaining spring 3. Programming button 4. Programming LED 5. Battery compartment

Programming/Test button: short press to set programming mode. If this button is held while connecting the battery, it enters the safe mode.

Programming LED: programming mode indicator (red). When the device enters the safe mode, it blinks (red) every half second. During the start-up (reset or after power failure) and if the device is not in safe mode, it emits a red flash.

GENERAL SPECIFICATIONS

CONCEPT		DESCRIPTION	
Type of device		Electric operation control device	
Power supply	Voltage (typical)	3.6 VDC	
	Battery type	1/2AA (ER14250) Li-SOCI2	
	Expected battery lifetime ¹ (years)	3	
	Maximum consumption ²	mA	mW
		22.0	79.2
Communication type		KNX RF Ready (Semi-directional)	
Radio frequency		868.3 MHz	
Maximum transmitting power		20 mW (13 dBm)	
Operation temperature		0 .. +45 °C ³	
Storage temperature		-20 .. +55 °C	
Operation humidity		5 .. 95%	
Storage humidity		5 .. 95%	
Complementary characteristics		Class B	
Protection class		III	
Operation type		Continuous operation	
Device action type		Type 1	
Electrical stress period		Long	
Degree of protection		IP20, clean environment	
Installation		Flush-mounted in false ceiling	
RF Range ⁴		Up to 125 m in free-field	
Operation indicator		The programming LED indicates programming mode (red). The motion detections are indicated by a red flash (in case the LED is enabled).	
Weight		39 g	
PCB CTI index		175 V	
Housing material		PC/ABS FR V0 halogen free housing and HDPE lens.	

¹ Considering 200 detections per day and medium signal power.

² The maximum consumption depends on the transmission power parameterized.

³ Temperatures over 35 °C could decrease the detection range.

⁴ The maximum range depends on several factors such as environmental conditions, device orientation, type and thickness of the surrounding materials, etc.

INSTALLATION INSTRUCTIONS

1. Make a $\varnothing 51$ mm hole in the ceiling.
2. Remove the plastic strip that isolates the battery.
3. Insert the device into the ceiling hole and allow the retaining springs to close.
4. Fix it, paying attention that it is correctly levelled and oriented, and remove the protective plastic film from the lens.

To download the individual address or the application press the programming button before starting the ETS download.

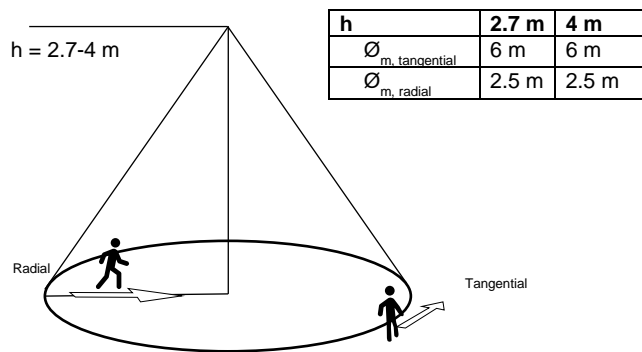
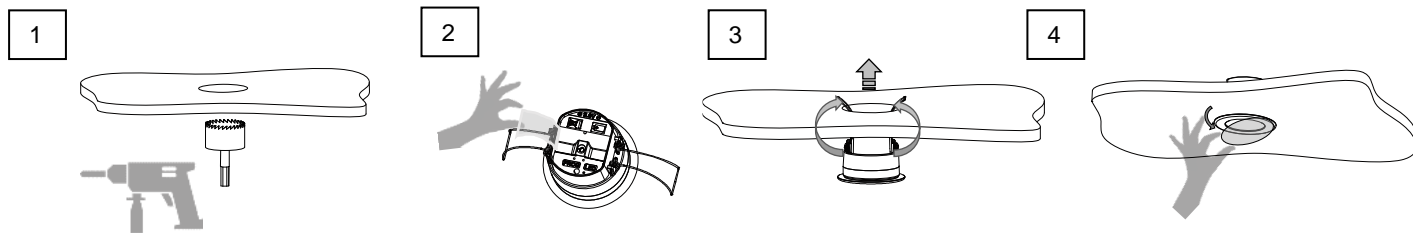
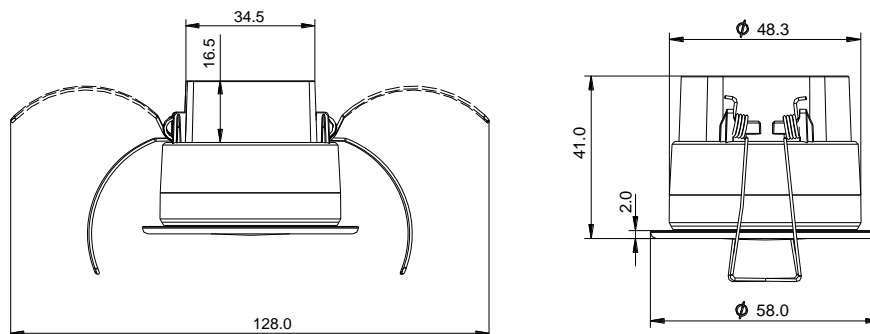

Figure 2: Motion detection range

BATTERY REPLACEMENT

1. Release the battery cover by loosening the screw.
2. Take out the used battery and press the programming button. Wait for some seconds (until programming LED is turned off) and then insert the new battery being careful not to damage the connections and put the battery cover back.
3. Insert the device into the ceiling hole and allow the retaining springs to close.
4. Fix it, paying attention that it is correctly levelled and oriented.

DIMENSIONS (mm)



SAFETY INSTRUCTIONS AND ADDITIONAL NOTES

- Installation should only be performed by qualified professionals according to the laws and regulations applicable in each country.
- This device is not suitable for security applications in alarm systems.
- Avoid to install the device close to radioelectric devices. The materials of the building and of the elements near the device could influence on its coverage range.
- This device uses Li-SOCI2 batteries, this kind of batteries have explosion risk in case of replacing them with wrong types batteries. Please, be careful during the battery replacement.
- Keep the device away from water (condensation over the device included) and do not cover it with clothes, paper or any other material while in use.
- The WEEE logo means that this device contains electronic parts and it must be properly disposed of by following the instructions at <https://www.zennio.com/en/legal/wEEE-regulation>.
- This device contains software subject to specific licences. For details, please refer to <https://zennio.com/licenses>.